



RCMTM
HEATING



ECO & SAFE | VOLTAGE **24**

New Practic

Trench heaters

Contents of the Catalogue

Clue	1
Basic Information about New Practic	2
EC technology	3
Construction	3
Overview of trench heaters with fan	4
An overview of trench heaters with natural convection	5
Grilles	6
FRT - Trench heaters with a fan	8
FRT - How to size the trench heater	9
Acoustics	10
FRT - Accessories	11
FRT - Trench heater with fan products	14-57
FRK - Trench heaters with natural convection	58
FRK - Accessories	60
FRK - Trench heaters with natural convection products	62-75
Atypical trench heaters	76
Heat exchanger - Hydraulic resistance	78
Electric connection of trench heaters with fan	79
Electrical diagram	80
The coding of trench heaters New Practic	82

Product range overview

Trench heaters with fan 14-57

FRT 0065 0250	14
FRT 0065 0300	16
FRT 0080 0175	18
FRT 0080 0200	20
FRT 0080 0250	22
FRT 0080 0300	24
FRT 0090 0175	26
FRT 0090 0200	28
FRT 0090 0250	30
FRT 0090 0300	32
FRT 0090 0425	34
FRT 0110 0175	36
FRT 0110 0200	38
FRT 0110 0250	40
FRT 0110 0300	42
FRT 0110 0425	44
FRT 0125 0250	46
FRT 0125 0300	48
FRT 0125 0425	50
FRT 0140 0250	52
FRT 0140 0300	54
FRT 0140 0425	56

Trench heaters with natural convection 62-75

FRK 0080 0250/FRK 0080 0300	62
FRK 0090 0175/0200/0250/0300/0425	64
FRK 0110 0175/0200/0250/0300/0425	66
FRK 0125 0175/0200/0250/0300/0425	68
FRK 0140 0175/0200/0250/0300/0425	70
FRK 0165 0300/FRK 0165 0425	72
FRK 0200 0300/FRK 0200 0425	74

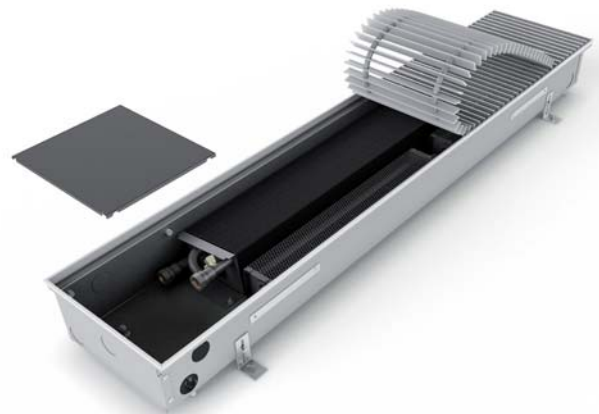



Clues



marking of an environmentally friendly product with low consumption, economical operation, working on the basis of safe direct current voltage of 24 V DC



trench heater with fan, increased output with forced convection



heating, a trench heater for hot water heating system with forced circulation



acoustic pressure parameters of trench heaters with fan



power input for trench heaters with fan

Basic Information about New Practic

Use

Trench heaters are suitable for places with large glass walls. They are installed in commercial and administrative buildings, commercial centres, entrance halls and other public spaces. They are also common in residential buildings, in which they are used to heat living rooms, corridors, halls and indoor gardens.

Placement

Trench heaters are installed in the floor and therefore do not occupy any space suitable for furniture and do not interfere with the interior the way traditional heating bodies do. The final look of the trench heater depends on the upper design grille. Available grilles are made of anodized aluminium, wood and stainless steel.

Operation

The trench heaters with fan are controlled with a digital thermostat with continuous control. This secures comfortable and economical operation at optimal thermal comfort and low noise level. All parts of the trench heaters work on the basis of safe direct voltage of 24 V DC.

The low volume of water in heat exchangers secures fast warming up to operating temperature. The trench heaters provide heating at the moment when it is necessary without a delay during start-up and without inertia when the requirement is cancelled.

Function

A "thermal screen" is created in front of a glazed surface, which separates the cold surface from the indoor environment. At the same time air flow prevents condensation of air humidity on the surface. The trench heaters are installed in the floor with the heat exchanger nearer to the window. The vertical and horizontal distribution of temperatures in the heated space is even and favourable conditions are created to secure thermal comfort.

Air flow is comparable with heat transmission provided by traditional heating bodies located on the wall under the window. The reversed arrangement in the floor is possible (the heat exchanger towards the room's centre, the ventilator at the window).

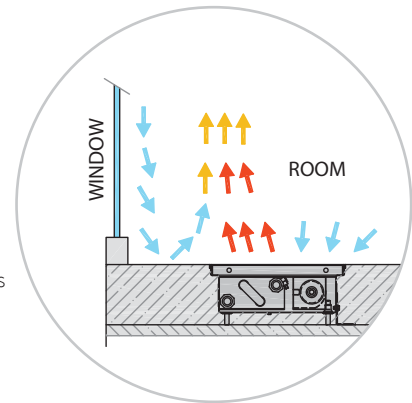

Low temperature heating systems

High performance models with modern tangential ventilators 24 V DC EC allow for the implementation into low temperature heating systems making use of thermal pumps and other ecological heating sources.

BMS

Trench heaters with the EC fans technology combined with a modern digital thermostat can easily be incorporated into building management systems (BMS). Communication with the superior system either directly or through a thermostat with an output for communication with the KNX protocol. For other systems it is possible to use protocol converters.

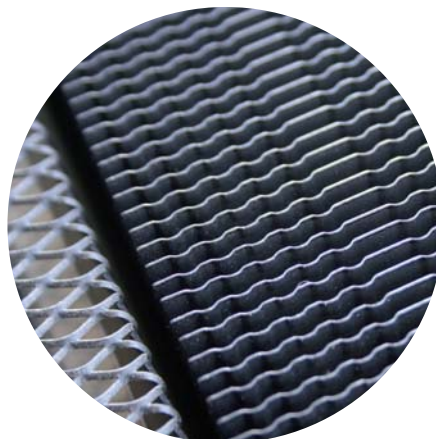

EC technology

This technical advancement affects all areas of human activity and enables the requirements for low energy consumption and safety of devices to be met. Modern 24 V DC fans with electronically commutated (EC) motors are among the most important elements of the trench heaters.

Properties of 24 V DC EC FANS



- Safe voltage of 24 V DC
- Remarkably low energy consumption, calculated in units of watts
- Comfortable continuous speed control using a voltage of 0...10 V DC
- Pulse to start the motor at low speeds
- Protection function when the rotor is stopped by an outside influence
- Synchronization of fan speeds
- Long service life of the motor with electronic control
- Simple implementation into complex control systems

The fans in New Practic trench heaters with their rotors cover the entire length of the exchanger. Even at low speeds they achieve optimum performance and a quiet operation.

Trench heater design

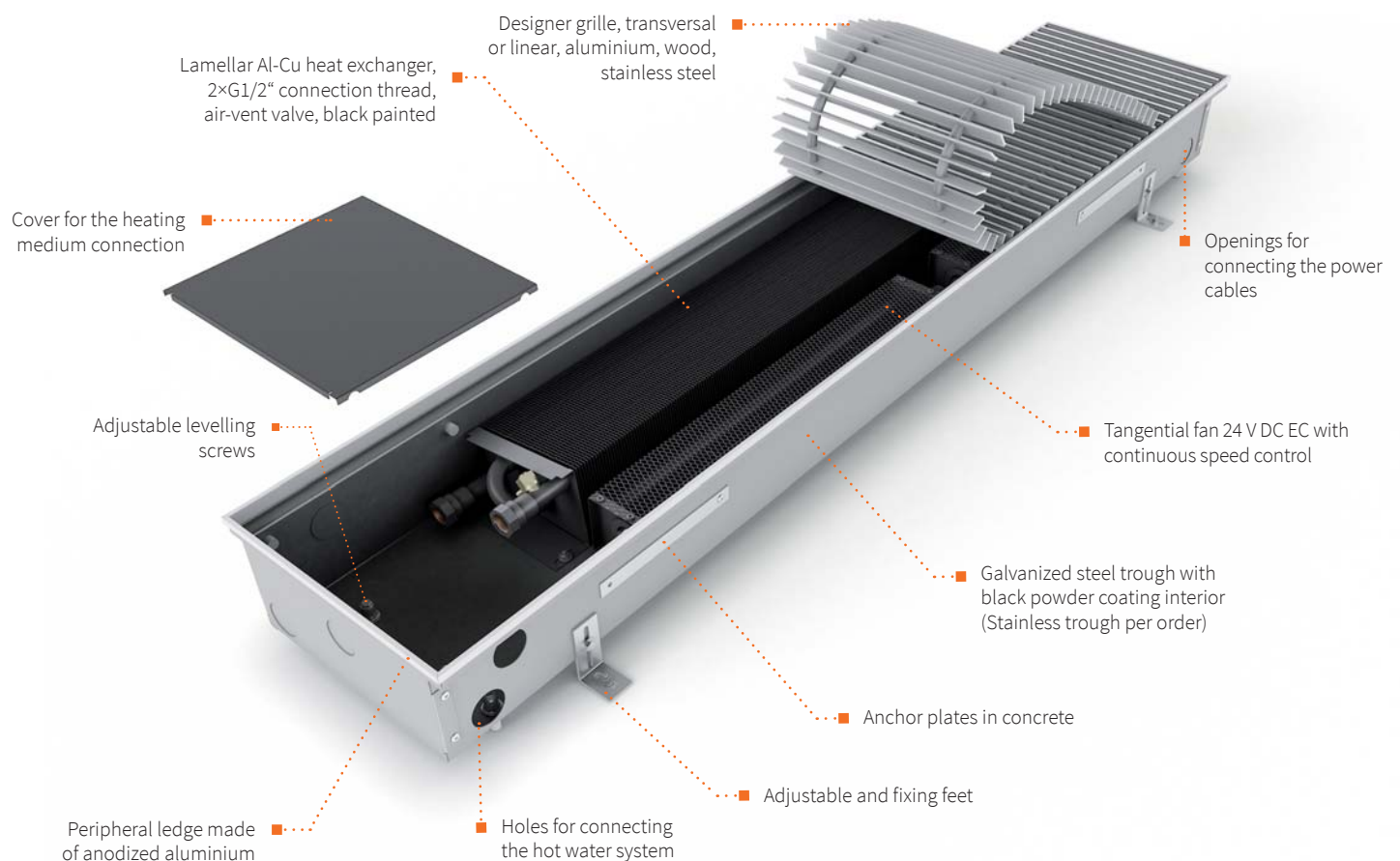



FRT - overview of trench heaters with fan

175

200

250

300

425

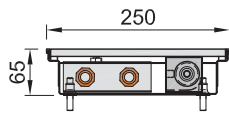

FRT 0065 0250
page 14

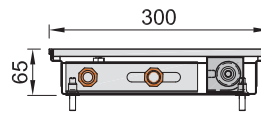

FRT 0065 0300
page 16

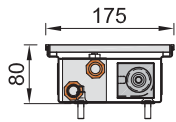

FRT 0080 0175
page 18

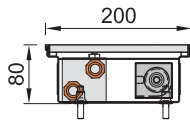

FRT 0080 0200
page 20

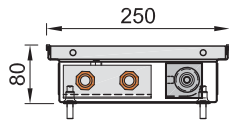

FRT 0080 0250
page 22

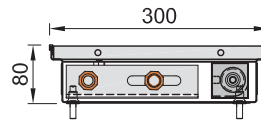

FRT 0080 0300
page 24

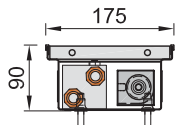

FRT 0090 0175
page 26

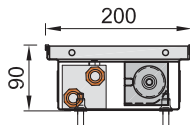

FRT 0090 0200
page 28

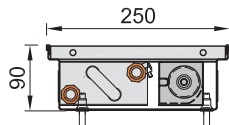

FRT 0090 0250
page 30

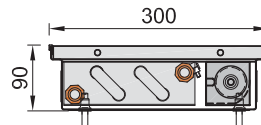

FRT 0090 0300
page 32

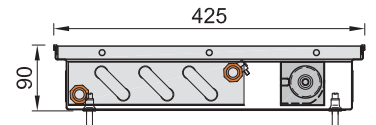

FRT 0090 0425
page 34

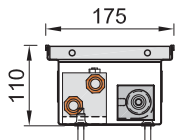

FRT 0110 0175
page 36

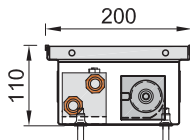

FRT 0110 0200
page 38

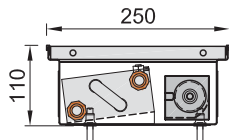

FRT 0110 0250
page 40

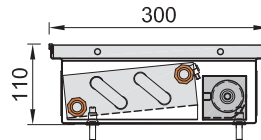

FRT 0110 0300
page 42

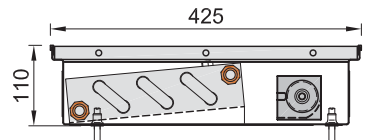

FRT 0110 0425
page 44

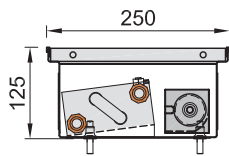

FRT 0125 0250
page 46

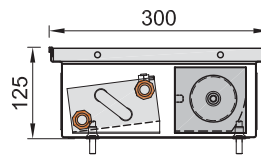

FRT 0125 0300
page 48

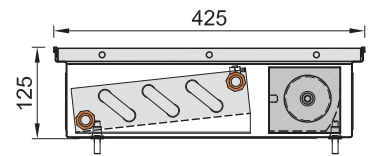

FRT 0125 0425
page 50

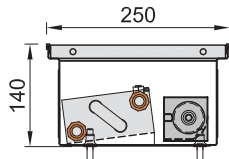

FRT 0140 0250
page 52

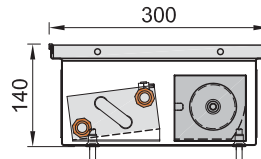

FRT 0140 0300
page 54

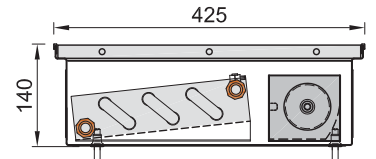

FRT 0140 0425
page 56

Trench heaters according to the customer's requirements

For the needs of large projects we may adjust the dimensions, structure and internal arrangement. A solution for humid spaces, the connection of an air handling system with modified air. Thermal output measurements will be supplied with the project.

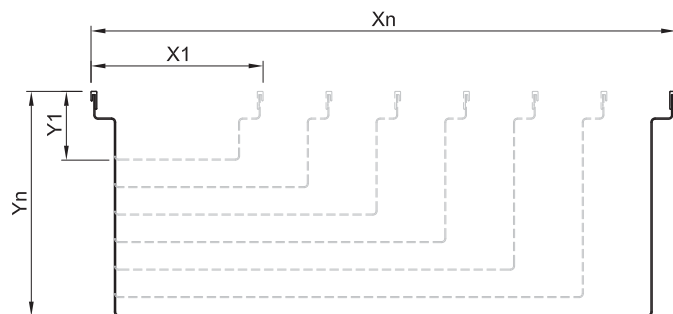

FRK - an overview of trench heaters with natural convection

175

200

250

300

425

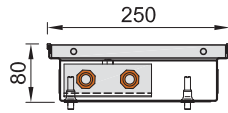

FRK 0080 0250
page 62

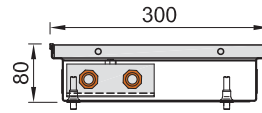

FRK 0080 0300
page 62

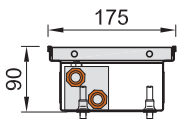

FRK 0090 0175
page 64

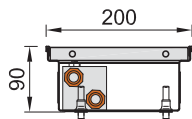

FRK 0090 0200
page 64

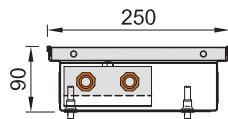

FRK 0090 0250
page 64

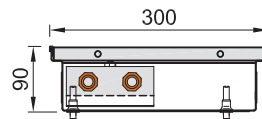

FRK 0090 0300
page 64

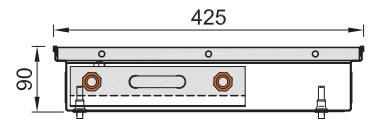

FRK 0090 0425
page 64

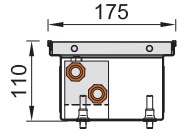

FRK 0110 00175
page 66

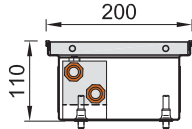

FRK 0110 0200
page 66

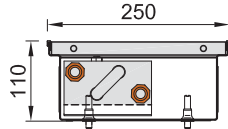

FRK 0110 0250
page 66

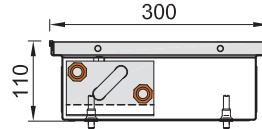

FRK 0110 0300
page 66

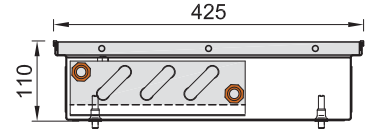

FRK 0110 0425
page 66

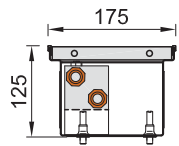

FRK 0125 0175
page 68

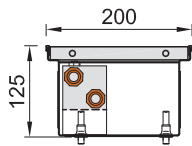

FRK 0125 0200
page 68

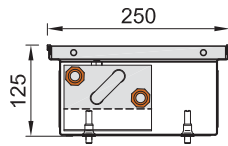

FRK 0125 0250
page 68

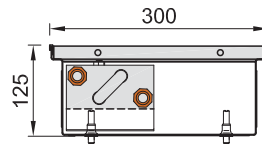

FRK 0125 0300
page 68

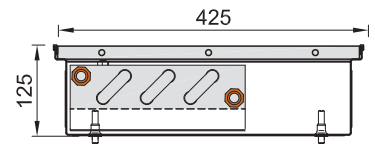

FRK 0125 0425
page 68

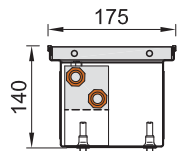

FRK 0140 0175
page 70

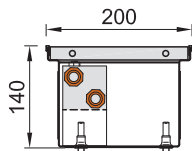

FRK 0140 0200
page 70

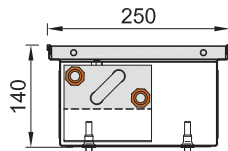

FRK 0140 0250
page 70

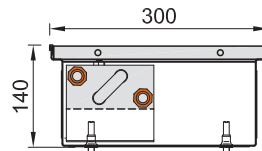

FRK 0140 0300
page 70

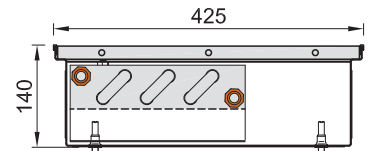

FRK 0140 0425
page 70

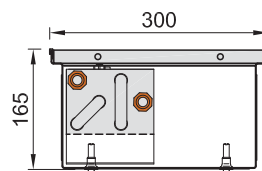

FRK 0165 0300
page 72

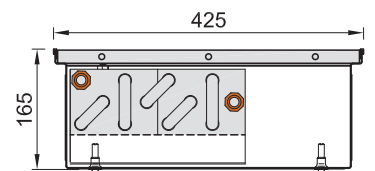

FRK 0165 0425
page 72

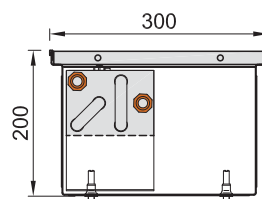

FRK 0200 0300
page 74

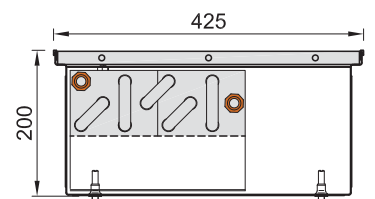

FRK 0200 0425
page 74

Grilles

The lamellas in grilles are made of anodized aluminium. The surface is durable and resistant to abrasion and its colours are stable. The lamellas are supplied in the following colours: NATUR, BRONZE and BLACK.

Aluminium low transverse grilles

For models **FRT 0065 0250, FRT 0065 0300, FRT 0080 0175, FRT 0080 0200**

The grille of the low trench heater type. It allows for installation into floor configuration with the heights of 65 and 80 mm. The aluminium lamellas are pressed into plastic longitudinal strips of black colour. The grille is supplied in segments that are linked into a single grille at the construction site.

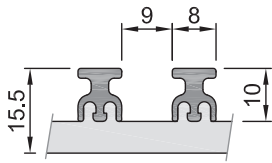

Grille's cross section



NATUR - marking 15

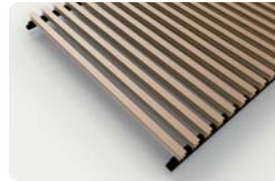

BRONZE - marking 25



BLACK - marking 35

Aluminium roll-up transverse grilles

Transverse lamellas are linked with a loaded spring and their limits are defined with distance rolls of hardened plastic. The rolling of the grille facilitates handling in the course of the installation and cleaning of the trench heater. The plastic rolls are assigned as follows based on the colour of the lamellas: NATUR – silver, BRONZE – black, BLACK – black. The lamellas may be provided with a surface finish of sprayed powder colour according to the RAL sample list.

The maximal length of the grille in one piece is **6 500 mm**.

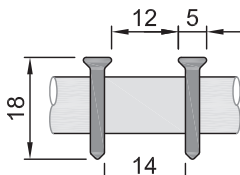

Grille's cross section



NATUR - marking 11



BRONZE - marking 21



BLACK - marking 31

Note: the grilles cannot be used for trench heaters **FRT 0065 0250, FRT 0065 0300, FRT 0080 0175, FRT 0080 0200**.

Aluminium linear non-rolling grilles

Aluminium lamellas provided with holes along their length and joined with a steel supporting bar. The grille is divided into more pieces for easy handling. The span between the lamellas is defined by distance rolls of hardened plastic. The plastic rolls are assigned as follows based on the colour of the lamellas: NATUR – silver, BRONZE - black, BLACK – black. The lamellas may be provided with a surface finish of sprayed powder colour according to the RAL sample list.

The maximal length of a single piece is **3 000 mm**. Greater lengths can be achieved by linking more pieces together.

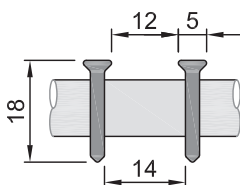

Grille's cross section



NATUR - marking 12



BRONZE - marking 22



BLACK - marking 32

Note: the grilles cannot be used for trench heaters **FRT 0065 0250, FRT 0065 0300, FRT 0080 0175, FRT 0080 0200**.

Wooden roll-up grilles

The grilles are manufactured as a roll-up version, i.e. a transverse roll-up grille. The material used is beech and oak. It is possible to order grilles made of wood in natural state or of stained wood. The grilles are a suitable complement of interiors and can be harmonized with a wooden or floating floor. Additional surface modification may be used to increase the resistance and durability of the grille's material.

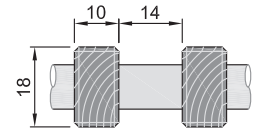

Grille's cross section

Surface finish NATUR – natural wood

Processed wood without an additional surface finish. The wood can be left in the raw state or provided with a surface finish to protect the wood. Based on the type of protection required and the external look (harmonizing with the interior) use staining, oil impregnation, waxing or varnish. The plastic rolls for the NATUR version are in beige.



BEECH NATUR - marking 61



OAK NATUR - marking 63

Surface finish STAINED – stained wood

The wooden lamellas of the grille are stained with a penetrating dyestuff to secure a darker brown colour. This brings out the wood grain and provides a basic surface protection. The plastic rolls are in black.



STAINED BEECH - marking 62



STAINED OAK - marking 64

The maximal length of the wooden grille in one piece is **6 500 mm**.

Note: the grilles cannot be used for trench heaters **FRT 0065 0250, FRT 0065 0300, FRT 0080 0175, FRT 0080 0200**.

Stainless roll-up grilles

The grilles are of stainless pieces with the cross section of 20x10mm. The robust look, firmness and stiffness are advantages of this variant. The default version supplied is an interior version in which the lamellas are joined with a spring and separated with distance rolls of hardened plastic. The plastic rolls are in silver colour.

At request we can supply the version without the roll-up function with a rigid structure for car showrooms (marking 51).

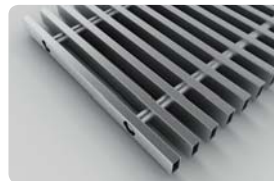

STAINLESS - marking 52

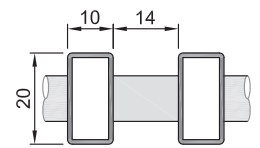

Grille's cross section

The maximal length of the stainless grille in one piece is **3 000 mm**.

Note: the grilles cannot be used for trench heaters **FRT 0065 0250, FRT 0065 0300, FRT 0080 0175, FRT 0080 0200**.

Peripheral ledge

It forms the architectural and functional borders of the trench heater after its installation in the floor. The ledge of anodized aluminium is available in colours „NATUR“, „BRONZE“ and „BLACK“. The peripheral ledges can be provided with a surface finish of sprayed powder colour according to the RAL sample list. A trench heater without the peripheral ledge can be supplied for the hidden installation of the trench heater in the floor. In such case this should be written down in the form of a note (a different width of the grille)



The ledge of anodized aluminium

Ledge „J“

A standard ledge that forms an architectural frame alongside the perimeter of the trench heater. Used for installation into floors that fit closely to the trench heater's body. Suitable for paving, architectural concrete, polished concrete floors, stone floors, lino, cork, ...

The ledge is permanently installed during the manufacture of the trench heater.

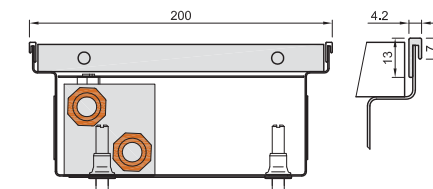

Ledge „L“

A peripheral ledge with an overlap. The L cross section 15x15x1.5 enables the covering of the expansion gap with the width of up to 10 mm. The ledge is put besides the trench heater. It is installed after the final floor is completed. It is glued onto the inner edge of the trench heater. When installing the trench heater should be installed in a way so it does not exceed the level of the final floor. Suitable for wooden floors, plywood floors, laminate flooring, vinyl. It can be used in cases when the technology of the floor laying requires an expansion gap. The length and width of the trench heater is greater by 21 mm than the dimensions presented in the catalogue.

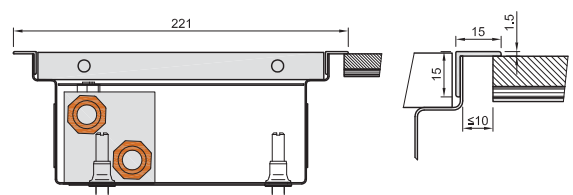

New Practic – FRT trench heaters with a fan



Trench heaters FRT with forced convection via a fan provide a very good thermal output. This is achieved via installed fans with longitudinal tangential rotors, which force air into a heat exchanger with lamellas. The fans are fitted with effective electrically commuted (EC) motors functioning on the basis of safe voltage of 24 V DC. The motors have very small consumption of electric power. The speeds of fans are controlled continuously with a controlling voltage of 0...10 V DC. The room thermostat secures the correct function of all installed FRT trench heaters, compares the set and actual temperature in the room, opens the flowing of heating medium in the heat exchanger and controls the fan's revs according to the difference in the temperatures and the set mode of operation.

The use of new technologies secures the optimal heating of the interior, which results in energy savings, the economical operation of the trench heater, the high efficiency and flexibility of heating. The trench heater is powered with safe voltage only, all components are powered with direct current of 24 V.

The substantial range of the heights and widths of trench heaters gives the designer a lot of options for selecting a model with the required output for the composition of the floor in question. The necessary data are presented in data sheets of individual products, including the acoustic parameters of the trench heaters.

The range of FRT models with a fan 24 V DC

Height	65 mm	80 mm	90 mm	110 mm	125 mm	140 mm
Width	-	175 mm	175 mm	175 mm	-	-
	-	200 mm	200 mm	200 mm	--	-
	250 mm	250 mm	250 mm	250 mm	250 mm	250 mm
	300 mm	300 mm	300 mm	300 mm	300 mm	300 mm
	-	-	425 mm	425 mm	425 mm	425 mm

Trench heater „made to measure“

Based on the requirements of larger projects it is possible to supply a „made to measure“ trench heater with adjusted height and width. Having approved the structure we will submit a protocol from a test room presenting output parameters. We also offer modifications of the trench heater for the use in humid environment, the connection of air handling piping and others. The technical documentation is first consulted with the customer and only then the production of the trench heater starts.

Operating conditions

- Installation in a hot water heating system with forced circulation
- Maximal operating temperature of heating medium 110 °C
- Maximal operating overpressure 1 MPa
- Electric parts with IP20 cover protection, use in dry environment
- Operating voltage 24 V DC
- Ambient temperature +2 to +40 °C
- Relative humidity of environment 20 to 70%

Placement in the floor

The trench heaters are laid in the floor so that the heat exchanger is closer to the window side, while fans are placed deeper into the room. The vertical and horizontal distribution of temperatures in the heated room is uniform and conditions are created to provide thermal comfort. Air flow is comparable to the heat transfer with classical heating bodies placed on the wall below windows.

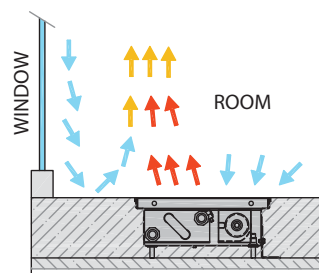

Connecting in the heating system

Lamellar Al-Cu heat exchangers have aluminium lamellas pressed onto a copper pipe through which the heating medium flows. The pipe's outlet and inlet are equipped with a connecting end with internal thread G1/2". Normally the water connection of the exchanger is on the left side (when the exchanger is placed nearer the window). We install a thermostatic valve fitted with an electrothermal actuator on the inlet of the lamellar heat exchanger. The actuator works in the opened/closed mode and controls the flow of the heating medium. It is not necessary to use a thermostatic valve if the temperature of the heating medium is controlled by the heating system (e.g. equithermal system). The way of regulation is to be determined by the designer of the heating and this shall be specified in the project documentation. A return regulating screw connection shall be used for the outlet. This enables the incorporation of the trench heater into the heating system from the viewpoint of the hydraulic balancing. Based on the parameters of the screw connection used the designer determines the setting (corresponding to pressure loss at the fitting) and this value shall be specified in the project documentation. Each exchanger is fitted with an air vent valve. When the heating system is connected and filled air bubbles remain caught in the upper part of the exchanger. These shall be let out through the air vent valve.

Connecting to the mains

The connection into the electric circuit is done according to the scheme. The entire circuit is powered with a switched power supply (placed in the switchboard), which provides the voltage of 24 V DC. All trench heaters and the room thermostat are connected to this voltage. The cabling shall be sized to ensure that the voltage in distribution lines never drops below 22 V DC in any individual device. More details concerning the sizing of the electric circuit are presented on page 79.

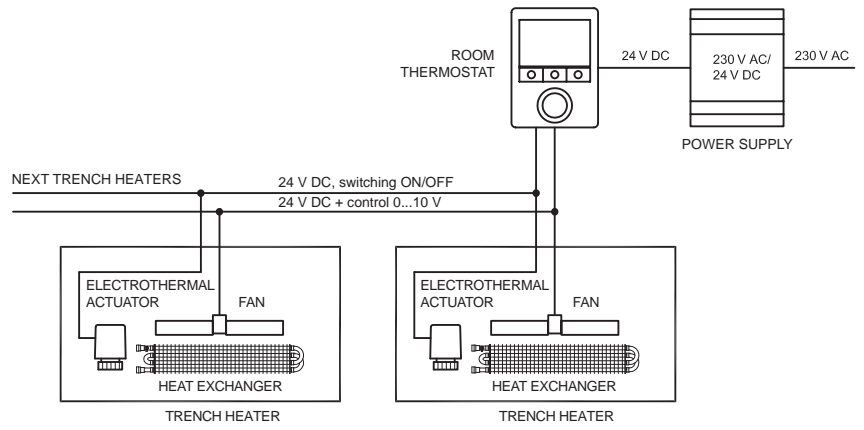

Hydraulics

- Tables with hydraulic resistance are presented on page 78.
- Some trench heaters have a too high output at thermal gradient of 75/65/20°C, during the calculation of the required flow and hydraulic resistance we will exceed the recommended limitations.
- We design such trench heaters for low-temperature systems or systems with a high difference between inlet and outlet, in which the output and thus also the flow of the heating medium are at acceptable level. Let us consider the flow rate of the heating medium to be up to 300 kg/hour. The designer may increase the flow in the trench heater's exchanger being aware of the fact that this will increase hydraulic resistance and flow rate in the piping (correct sizing of overpressure and the pump), the table with hydraulic parameters is presented on page 76.
- If the output is too high, it is possible to use a trench heater with a reduced number of fans; it is best to consult our technical department if this variant is to be selected.

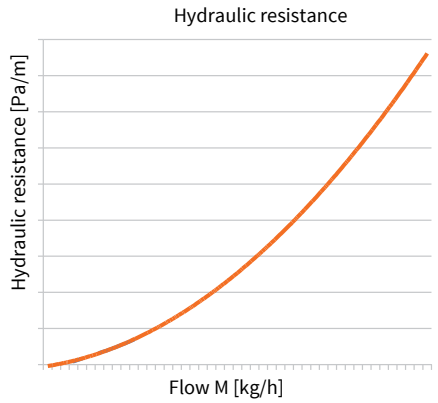

HOW TO SIZE THE TRENCH HEATER

What room the trench heater is to be placed in

We always consider output and acoustic parameters of the trench heater taking into account the room's nature – residential rooms, bedrooms, corridors, offices, theatres, hospital rooms, halls, presentation rooms and others. The trench heater shall comply with the requirement for thermal output at a selected temperature gradient, however at the same time the operation shall not disturb the user with excessive noise. The noise issue is regulated by the applicable standard, which defined permitted limits for individual types of rooms. (more info on page 10).



The output of the trench heater

The tables contain output data for thermal gradient 75/65/20°C, standardized output according to standard EN 442-2. This standard also defines the procedure for conversion to other thermal gradients. The second table presents a converted thermal gradient of 55/45/20°C and a fast approximate conversion for gradients of 90/70/20°C and 70/55/20°C.

- Convert the output to the required thermal gradient, check acoustic parameters.
- It is not a problem if the calculated output is higher than the required one – the automatic regulation functions from the lowest revs per the output that is equal to the current thermal loss in the room, the trench heater will not overheat, on the contrary it will function with less noise (it will achieve the required output at lower revs), the comfort temperature in the room will be achieved faster

Warranty conditions

The warranty provided by the seller applies to tightness, surface finish, specified values of thermal outputs and pressure losses of heating bodies professionally installed in the closed hot water system according to applicable standards and regulations, including corrosive properties of the heat transferring medium, which shall be used exclusively for heating and never for other utility purposes. Bodies with power input shall be installed professionally according to applicable standards and regulations specifying the placement of appliances. FRT trench heaters with the fan with IP20 protection cover – dry environment.

Warranty periods

The warranty period for the tightness of connections is 5 years, 10 years applies to the heat exchanger and 2 years to the electric installation and galvanized steel trough.

Acoustics

When planning trench heaters FRT fan for residential rooms it is necessary to take into account the acoustic characteristics of the trench heater and the environment in which it will be used. It is necessary to design a trench heater complying with the applicable standard, which defines acoustic limits for individual environments. The values are prescribed by a national directive, which shall be observed – there may be differences in individual EU states. In general one can say that the upper limit for a daily room is 40 dB(A), the limit for rooms with night or relaxation regime is lowered to 30 dB(A), the limit for offices is 50 dB(A) and so on.

Different requirements for different rooms

- entrance halls, corridors, waiting rooms, foyers
- office space, administrative rooms
- residential rooms, public buildings, car showrooms, shops
- rooms for relaxation and rest (residential rooms, bedrooms)

Acoustic parameters in the catalogue

The acoustic parameters specified in the New Practic catalogue for individual products are valid for residential space “with standard equipment”. This means that the room is equipped in the standard way. Curtains, drapes, possibly Venetian blinds are fitted at windows, the floor or a part thereof is covered with a carpet, furniture is present. All these elements absorb or dissipate acoustic waves in the room.

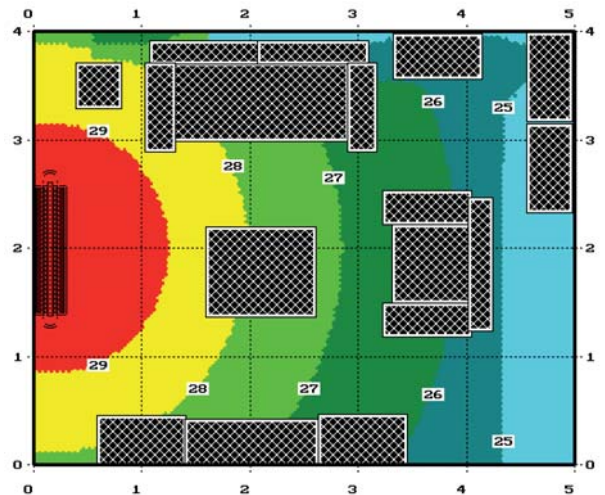

Changes and the influence on acoustic pressure

The type of space for which we design the New Practic trench heater has fundamental influence on the total noise level of the environment connected with its operation. Reverberation occurs, resounding waves take relatively long time to die down (they are not absorbed), they mutually influence and magnify each other. The total level of acoustic pressure can be increased by as much as 3-6 dB(A).

- The undesirable effect of acoustic pressure is increased by trench heaters installed near corners or under ceiling without cover.
- rooms with minimalistic equipment without dampening elements and with a resounding floor without any cover have significant impact on the worsening of the total acoustics of the space. From the viewpoint of the assessment of the acoustic limit the influence of the room (with or without equipment) is not taken into consideration, the regulation assesses the fitness of the room in its current condition (at the time of measuring). In practice an empty room may be measured. Therefore the designer of the heating system shall take into account all possible variants of installation into a given space or he/she may draw the investor's attention to available solutions using an alternative (more powerful, less noisy) trench heater in atypical cases.
- it is important to take into consideration acoustic parameters when installing more trench heater in a single room. Acoustic pressures of individual trench heaters mutually influence one another, resulting in an increase of the total noise level. It all depends on the type of the room, the characteristics of the trench heater and the distance between individual bodies. It is necessary to design heating bodies with a sufficiently low level of acoustic pressure at the selected output and the revs of the fan.

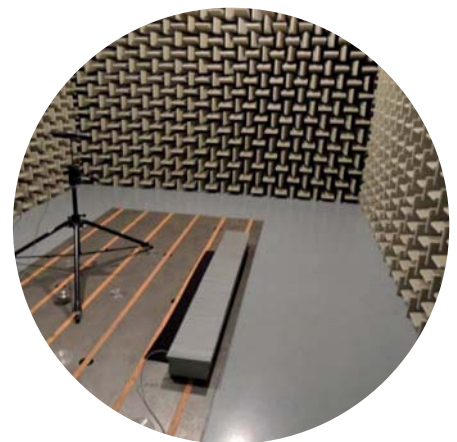

View of the testing acoustic chamber

The designer shall take into account all aspects of the room in which the trench heater is to be installed. (i.e. the equipment, dampening elements, floating or double-layer floor etc.)

Measuring the acoustic pressure

The measuring took place in semi-anechoic chamber. The acoustic chamber complies with ISO 3745 standard in terms of frequency range 100 Hz to 20 kHz. An accurate Brüel and Kjaer phonometer was used for measuring which complies with 1st category of measuring accuracy. The measuring methodology is based on the recommendations specified in the Methodology manual for noise measuring and assessment in non-working environment. Sensing device was placed diagonally one meter above the trench heater and 1 meter from the trench heater into the room. The values were adjusted to the conditions of a room with „standard equipment“ with standard reverberation and reflectance.

FRT - accessories

Controls and a power supply need to be added to trench heaters to secure their correct function. The temperature in the room is assessed by a room thermostat (RTD201), which controls the fan's revs and the flow of heating medium through the heat exchanger. The flow is controlled via an electrothermal actuator (Z-TS24), which opens or closes a thermostatic valve (Z-TD001, Z-TE001). We install the thermostatic valve at the inlet of the heat exchanger. In order to adjust the flow of the heating medium it is necessary to install and set a screw joint (Z-RD001, Z-RE001) at the exchanger's outlet. The entire circuit functions on the basis of safe voltage of 24 V DC, which is provided by a power supply 24 V DC (DR, DRP), which shall be sized according to the number of installed trench heaters.

RTD201

ROOM THERMOSTAT

For controlling of trench heaters with fans 24 V DC EC and electrothermal actuators 24 V DC

Description

- Digital room thermostat with backlit LCD display
- Week program, 8 time blocks/day
- Manual or automatic switching of speeds
- Operating modes: Comfort, Economy and Protection
- Colour of front cover: white RAL9003

Parameters

- Temperature range 5-40 °C (Comfort mode)
- Rated voltage 24 V DC
- Power consumption max. 2 VA/1 W
- Control of fans 24 V DC EC 0...10 V DC EC, max. ±5 mA
- Max. connecting of 10 pieces of electrothermal actuators Z-TS24
- Degree of protection IP30
- Ambient temperature 0-50 °C
- Relative humidity <95%
- Dimensions: 128×93×31 mm



Setting the thermostat

When putting into operation it is necessary to switch over the DIP switch and set the thermostat's internal parameters, for more see the page 79.

Optional accessories

- External temperature sensor TE40
- Sensor of exchanger's temperature TE30
- Remote infrared control RC10
- Possibility to connect open window sensor

DR60-24 / DR100-24 / DRP240-24 / DRP480-24

POWER SUPPLY

Converts the mains voltage of 230 V AC to safe voltage of 24 V DC, power supply made ready for installation on DIN bar.

Description

- For the placement of the source provide sufficient space in the switchboard
- Size the output to fit the input of installed bodies and cabling, provide 5% output reserve on the source against calculated consumption
- DR60-24 and DR100-24 may be installed in a box for wall installation



DR60-24, 60 W
24 V DC, 78×93×56 mm



DR100-24, 100 W
24 V DC, 100×93×56 mm



DRP240-24, 240 W
24 V DC, 126×126×100 mm



DRP480-24, 480 W
24 V DC, 227×126×100 mm

Z-TS24 / Z-TS24-5m

ELECTROTHERMAL ACTUATOR 24 V DC

Opened/closed function (without voltage closed).

Parameters

- Input voltage: 24 V DC
- Power consumption: at switch-on 6 VA, input at operation: 2,5 W
- Opening/closing time: 270 s
- Degree of protection: IP54 cover of the casing
- Connection to valve: M30×1,5 mm
- Total height at max. lift: 74 mm
- Colour of actuator and cabel: black RAL9005

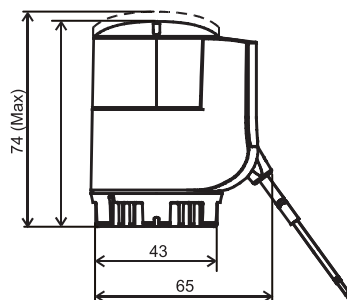

Z-TS24 cable length 3 m
Z-TS24-5m cable length 5 m

Z-TD001 / Z-TE001

THERMOSTATIC VALVE DIRECT AND CORNER
Direct and corner thermostatic valve, heating medium flow regulation in the system, installation on the heat exchanger's inlet pipe direct/corner.

Parameters

- Size: DN15, NF standard
- Connecting thread: M30x1,5 mm
- Max. operating temperature 120 °C
- Max. operating pressure PN10
- Option to change pre-setting of kv-value
- kv value (m³/h) range 0.10-0.89
- kv value (m³/h) for zone 2K 0.52

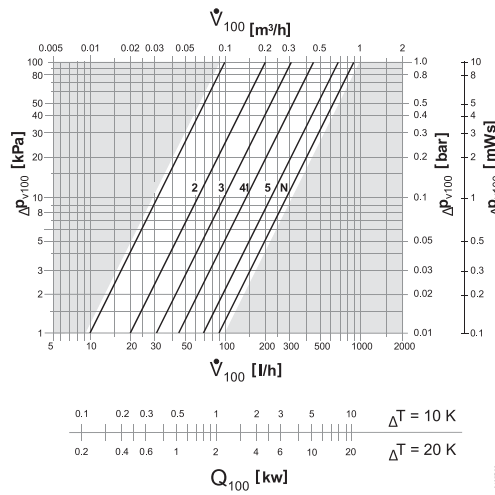

Z-TD001
direct thermostatic valve



Z-TE001
corner thermostatic valve

Z-RD001 / Z-RE001

LOCKSHIELD VALVE DIRECT AND CORNER

Direct and corner closing and regulation screw connection, flow setting, installation on the exchanger's outlet pipe.

Parameters

- Size: DN15
- Value kvs
direct 0.30-1.80
corner 0.30-3.00
- Max. operating temperature: 110 °C
- Max. operating overpressure: 10 bar

Kv (°) T - Speed	0,5	0,75	1	1,5	2	2,5	3	3,5	4	5	6	Max.
Kv (m³/h) - direct type	0,3	0,4	0,55	0,75	0,91	1,05	1,25	1,33	1,4	1,6	1,7	1,8
Kv (m³/h) - corner type	0,2	0,25	0,29	0,4	0,5	0,69	0,8	1	1,2	1,55	1,9	2,2



Z-RD001
direct screw connection



Z-RE001
corner screw connection

RL10

RELAY

The thermostat RTD201 allows for the connection of 10 pieces of electrothermal actuators at most, if the number of installed actuators is higher use RL10 according to the electric scheme.

Parameters

- voltage in winding 24 V DC
- Degree of protection IP20
- Max. switching current 12 A
- Without voltage: disconnection
- 37x20x39 mm
- Max. operating temperature 60 °C



PR40, PR50

EXTENSION PIECES WITH ELBOWS

For easy connection of the trench heater to the heating system in the direction towards the room centre. The length of the extension piece and the types of elbows will set the connection points opposite the openings in the trench heater's trough.

PR50 extension piece 50 mm, 2xelbow 90°

- Use for models
- FRT 0065 0250
 - FRT 0065 0300
 - FRT 0080 0250
 - FRT 0080 0300

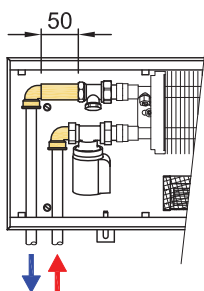

PR40 - extension piece 40 mm, 2xelbow 90°

- All other models FRT, except for the ones stated with PR50

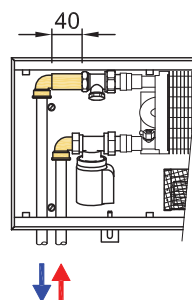

2x



1x

KP10

BOX FOR POWER SUPPLY

Box to place under plaster, for the installation of the power supply.

Parameters

- Option of installation of DR60-24 and DR100-24
- Attachment to DIN bar
- Installation under plaster, hidden in the wall
- 234×176×79 mm
- For the case when more supplies need to be installed
- When the space in the switchboard is not sufficient



TE30

SEPARATED TEMPERATURE SENSOR (BLOCKING OF REVS) / for thermostat RTD201

Parameters

- Separated temperature sensor monitors temperature of heat exchanger, when the heat exchanger is cold it will not switch on fans
- Connection to thermostat RTD201
- Measuring range 0-40 °C
- Measuring sensor NTC, 3 kΩ at 25 °C
- Measuring accuracy at 25 °C: ±0.3 K
- Cable length ca. 2.5 m, can be adjusted, max. total length 80 m
- Temperature range 0-49°C



TE40

EXTERNAL SPATIAL SENSOR FOR TEMPERATURE / for thermostat RTD201

Parameters

- Measures room temperature on a different spot than the spot where the thermostat is installed
- Connection to thermostat RTD201
- Measuring range 0-40 °C
- Measuring sensor NTC, 3 kΩ at 25 °C
- Measuring accuracy at 25 °C: ±0.3 K
- Degree of protection IP30
- Operating temperature 0-50 °C
- Relative humidity <85 %
- White colour RAL9003
- 97×100×36mm



RC10

REMOTE CONTROL / for thermostat RTD201, Infrared

IRA211 is an infrared control for use with room thermostat RTD201. Communication between the remote control and the spatial regulator is one way. Current setting is shown on the display. Any change carried out directly on the spatial regulator will not be synchronized with the remote control.

Parameters

- Operating mode selection: Comfort, Automatic with a time mode or Protective mode
- Change of the setting of required spatial temperature in the Comfort mode
- Selection of the fan's operating mode: Automatic or manual selection of the fan's speed
- Operating distance (infrared transceiver), distance ≤ 7.5 m, angle ≤ ± 30 °



FRT 0065 0250

ECO & SAFE | **VOLTAGE 24**

TRENCH HEATER WITH FAN



- Flats, detached houses, offices, administrative buildings
- The lowest and the most narrow fan assisted trench heater
- High heating output
- Continuous speed control
- Quiet operation
- Common electricity consumption **2 W/m**
- Using in dry environment



Technical data

Trench heater

Height	H = 65 mm
Width	W = 250 mm
Length	L = 700-4 800 mm in step 100 mm

Heat exchanger

Type	Al-Cu lamellar
Length	L- 295 mm
Connection thread	2xG1/2" inner

Working conditions

Max. temperature	110 °C
Max. overpressure	1 MPa (10 bar)
Protection	IP 20
Ambient conditions	Temp. T = +2 to +40 °C Humidity Rh = 20 to 70 %

Variants

Transverse grilles - rigid

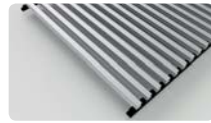

natur - anod. aluminium



bronze - anod. aluminium

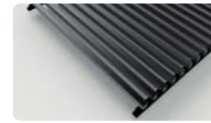

black - anod. aluminium

Peripheral ledge



(more on page 7)

- Low trench heaters are equipped with a non-rolling grille segment
- Only transverse grilles are delivered
- Colours natural, bronze, black

More possibilities and variants → page 6

Trench heater standard equipment

Trough	Galvanized steel trough with surface finish and black spray layer inside, black cover plates of connection
Heat exchanger	Al-Cu lamellar exchanger with air vent valve, black painted
Grille	Design walkable grille according the customer's choice
Ledge	Made of anodized aluminium, type and colour according the customer's choice
Fan	Modern tangential fan with 24 V DC EC motor with high efficiency
Assembly elements	Leveling screws for setting up the trough, mounting brackets
Manual	Manual for the progress of work during installation and user manual
Wiring	Electrical wiring diagram of the trench heaters
Mounting board	Cover and the spacer particle board for easy installation
Package	Transport package for protection against damage during transportation and handling

Accessories per order

	Room thermostat		Power supply
	Electrothermal actuator		Thermostatic valve
	Lockshield valve		

Accessories details → page 11

Technical drawing

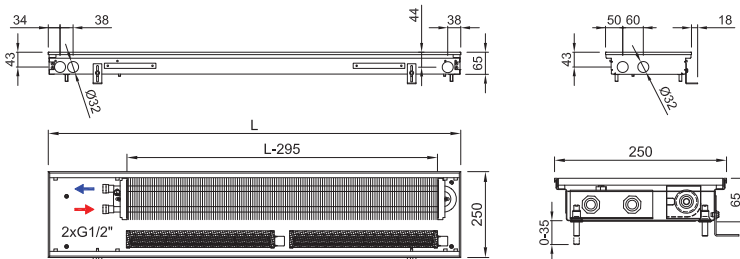

Connection to heating system

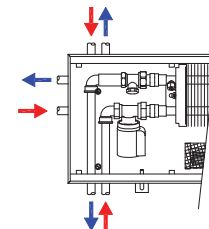

The hydraulic parameters of the heat exchanger → page 78

Code example: FRT 0065 0250 1600 C 15 J1 L - 5

Trench heater **FRT** H=**65** mm, W=**250** mm, L=**1 600** mm, „**C**“ Galvanized steel trough with black inside, heat exchanger and inner parts painted black, „**15**“ Low natural anodized aluminium grille, transverse, rigid, „**J1**“ peripheral ledge „**J**“, natur anodized aluminium, „**L**“ water connection at the left side (when installing the heat exchanger closer to the window, fans to the room), „**5**“ 24 V DC fans without controller (controller is not needed)

Trench heater heating output FRT 0065 0250

Q[W] 75/65/20 °C (ΔT=50 °C)

Temperature exponent 1,1

Length L [mm]	Speed [-] / Heating output [W]			
	1	2	3	4 max.
700	149 W	312 W	401 W	469 W
800	198 W	416 W	535 W	625 W
900	238 W	499 W	642 W	750 W
1000	337 W	707 W	909 W	1 062 W
1100	337 W	707 W	909 W	1 062 W
1200	396 W	832 W	1 069 W	1 249 W
1300	436 W	915 W	1 176 W	1 374 W
1400	486 W	1 019 W	1 310 W	1 531 W
1500	535 W	1 123 W	1 444 W	1 687 W
1600	586 W	1 229 W	1 580 W	1 846 W
1700	586 W	1 229 W	1 580 W	1 846 W
1800	674 W	1 414 W	1 818 W	2 124 W
1900	734 W	1 541 W	1 981 W	2 315 W
2000	784 W	1 645 W	2 115 W	2 471 W
2100	824 W	1 728 W	2 222 W	2 596 W
2200	824 W	1 728 W	2 222 W	2 596 W
2300	923 W	1 936 W	2 489 W	2 908 W
2400	923 W	1 936 W	2 489 W	2 908 W
2500	982 W	2 061 W	2 649 W	3 095 W
2600	1 022 W	2 144 W	2 756 W	3 220 W
2700	1 062 W	2 228 W	2 863 W	3 345 W
2800	1 121 W	2 352 W	3 024 W	3 533 W
2900	1 172 W	2 458 W	3 160 W	3 692 W
3000	1 172 W	2 458 W	3 160 W	3 692 W
3200	1 320 W	2 770 W	3 561 W	4 161 W
3400	1 370 W	2 874 W	3 695 W	4 317 W
3600	1 509 W	3 166 W	4 069 W	4 754 W
3800	1 558 W	3 270 W	4 203 W	4 910 W
4000	1 647 W	3 457 W	4 443 W	5 191 W
4200	1 757 W	3 688 W	4 740 W	5 538 W
4400	1 846 W	3 873 W	4 978 W	5 816 W
4600	1 956 W	4 104 W	5 275 W	6 163 W
4800	1 995 W	4 187 W	5 382 W	6 288 W

Q[W] 55/45/20 °C (ΔT=30 °C)

Length L [mm]	Speed [-] / Heating output [W]			
	1	2	3	4 max.
700	85 W	178 W	229 W	267 W
800	113 W	237 W	305 W	356 W
900	136 W	284 W	366 W	428 W
1000	192 W	403 W	518 W	605 W
1100	192 W	403 W	518 W	605 W
1200	226 W	474 W	609 W	712 W
1300	249 W	522 W	670 W	783 W
1400	277 W	581 W	747 W	873 W
1500	305 W	640 W	823 W	962 W
1600	334 W	701 W	901 W	1 052 W
1700	334 W	701 W	901 W	1 052 W
1800	384 W	806 W	1 036 W	1 211 W
1900	418 W	879 W	1 129 W	1 320 W
2000	447 W	938 W	1 206 W	1 409 W
2100	470 W	985 W	1 267 W	1 480 W
2200	470 W	985 W	1 267 W	1 480 W
2300	526 W	1 104 W	1 419 W	1 658 W
2400	526 W	1 104 W	1 419 W	1 658 W
2500	560 W	1 175 W	1 510 W	1 765 W
2600	583 W	1 222 W	1 571 W	1 836 W
2700	605 W	1 270 W	1 632 W	1 907 W
2800	639 W	1 341 W	1 724 W	2 014 W
2900	668 W	1 401 W	1 802 W	2 105 W
3000	668 W	1 401 W	1 802 W	2 105 W
3200	753 W	1 579 W	2 030 W	2 372 W
3400	781 W	1 639 W	2 107 W	2 461 W
3600	860 W	1 805 W	2 320 W	2 710 W
3800	888 W	1 864 W	2 396 W	2 799 W
4000	939 W	1 971 W	2 533 W	2 959 W
4200	1 002 W	2 103 W	2 702 W	3 157 W
4400	1 052 W	2 208 W	2 838 W	3 316 W
4600	1 115 W	2 340 W	3 007 W	3 514 W
4800	1 137 W	2 387 W	3 068 W	3 585 W

75/65/20 °C → 75 °C inlet temperature, 65 °C outlet temp., 20 °C room temp. / Output 90/70/20 °C = ~ 1,22 x 75/65/20 °C / Output 70/55/20 °C = ~ 0,84 x 75/65/20 °C / Heating outputs in accordance with EN442 / Not listed heating outputs for lengths per 100 mm steps calculate linearly.

Acoustic pressure [dB(A)]

Length L [mm]	Speed [-] / Acoustic pressure [dB(A)]			
	1	2	3	4 max.
700	< 20 dB(A)	20 dB(A)	25 dB(A)	29 dB(A)
800		21 dB(A)	26 dB(A)	30 dB(A)
900				31 dB(A)
1000				
1100				
1200		32 dB(A)		
1300			22 dB(A)	27 dB(A)
1400				
1500				
1600		33 dB(A)		
1700			23 dB(A)	28 dB(A)
1800				
1900				
2000		34 dB(A)		
2100			24 dB(A)	29 dB(A)
2200				
2300				
2400		35 dB(A)		
2500			25 dB(A)	30 dB(A)
2600				
2700				
2800	36 dB(A)			
2900		26 dB(A)	31 dB(A)	
3000				
3200				
3400	37 dB(A)			
3600		27 dB(A)	32 dB(A)	
3800				
4000				
4200	38 dB(A)			
4400		28 dB(A)	33 dB(A)	
4600				
4800				29 dB(A)
	30 dB(A)			

Acoustic pressure level choose according to specific environment. More details on page 10

Fans input power [W]*

Length L [mm]	Speed [-] / Fans input power [W]*			
	1	2	3	4 max.
700	1 W	1 W	2 W	2 W
800	1 W	1 W	2 W	2 W
900	1 W	1 W	2 W	2 W
1000	2 W	2 W	2 W	3 W
1100	2 W	2 W	2 W	3 W
1200	2 W	3 W	3 W	4 W
1300	2 W	3 W	3 W	4 W
1400	3 W	3 W	4 W	5 W
1500	3 W	3 W	4 W	5 W
1600	3 W	3 W	4 W	5 W
1700	3 W	3 W	4 W	5 W
1800	3 W	3 W	4 W	5 W
1900	3 W	4 W	5 W	6 W
2000	4 W	5 W	6 W	7 W
2100	4 W	5 W	6 W	7 W
2200	4 W	5 W	6 W	7 W
2300	4 W	5 W	6 W	7 W
2400	4 W	5 W	6 W	7 W
2500	5 W	6 W	7 W	9 W
2600	5 W	6 W	7 W	9 W
2700	5 W	6 W	7 W	9 W
2800	5 W	6 W	7 W	9 W
2900	5 W	6 W	7 W	9 W
3000	5 W	6 W	7 W	9 W
3200	6 W	8 W	9 W	11 W
3400	6 W	8 W	9 W	11 W
3600	7 W	8 W	10 W	12 W
3800	7 W	9 W	11 W	13 W
4000	7 W	9 W	11 W	13 W
4200	7 W	9 W	11 W	13 W
4400	8 W	10 W	12 W	14 W
4600	8 W	10 W	12 W	15 W
4800	8 W	10 W	12 W	15 W

* Approximate fan input powers / When using electrothermal actuator add in the trench heater's power 3 W / Wiring of the trench heater → page 80

FRT 0065 0300

ECO & SAFE | VOLTAGE 24

TRENCH HEATER WITH FAN



- Flats, detached houses, offices, administrative buildings
- Low construction of the trench heater
- High heating output
- Continuous speed control
- Quiet operation
- Common electricity consumption **2 W/m**
- Using in dry environment



Technical data

Trench heater

Height	H = 65 mm
Width	W = 300 mm
Length	L = 700-4 800 mm in step 100 mm

Heat exchanger

Type	Al-Cu lamellar
Length	L- 295 mm
Connection thread	2×G1/2" inner

Working conditions

Max. temperature	110 °C
Max. overpressure	1 MPa (10 bar)
Protection	IP 20
Ambient conditions	Temp. T = +2 to +40 °C Humidity Rh = 20 to 70 %

Variants

Transverse grilles - rigid



natur - anod. aluminium



bronze - anod. aluminium



black - anod. aluminium

Peripheral ledge



(more on page 7)

- Low trench heaters are equipped with a non-rolling grille segment
- Only transverse grilles are delivered
- Colours natural, bronze, black

More possibilities and variants → page 6

Trench heater standard equipment

Trough	Galvanized steel trough with surface finish and black spray layer inside, black cover plates of connection
Heat exchanger	Al-Cu lamellar exchanger with air vent valve, black painted
Grille	Design walkable grille according the customer's choice
Ledge	Made of anodized aluminium, type and colour according the customer's choice
Fan	Modern tangential fan with 24 V DC EC motor with high efficiency
Assembly elements	Leveling screws for setting up the trough, mounting brackets
Manual	Manual for the progress of work during installation and user manual
Wiring	Electrical wiring diagram of the trench heaters
Mounting board	Cover and the spacer particle board for easy installation
Package	Transport package for protection against damage during transportation and handling

Accessories per order

	Room thermostat		Power supply
	Electrothermal actuator		Thermostatic valve
	Lockshield valve		

Accessories details → page 11

Technical drawing

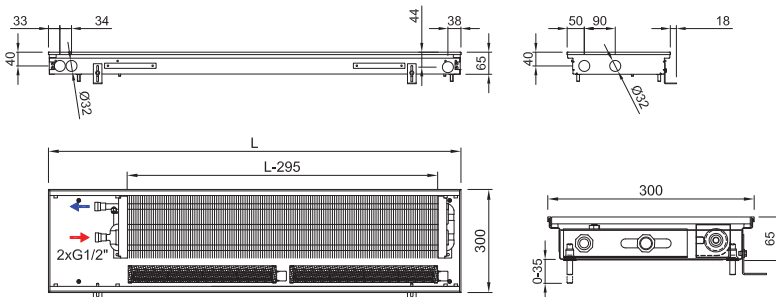

Connection to heating system

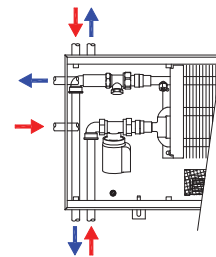

The hydraulic parameters of the heat exchanger → page 78

Code example: FRT 0065 0300 2000 C 25 J2 R - 5

Trench heater **FRT** H=65 mm, W= 300 mm, L=2 000 mm, „**C**“ Galvanized steel trough with black inside, heat exchanger and inner parts painted black, „**25**“ Low bronze anodized aluminium grille, transverse, rigid, „**J2**“ peripheral ledge „**J**“, bronze anodized aluminium, „**R**“ water connection at the right side (when installing the heat exchanger closer to the window, fans to the room), „**5**“ 24 V DC fans without controller (controller is not needed)

 **Trench heater heating output FRT 0065 0300**

Q[W] 75/65/20 °C (ΔT=50 °C)

Temperature exponent 1,1

Length L [mm]	Speed [-] / Heating output [W]			
	1	2	3	4 max.
700	179 W	388 W	495 W	559 W
800	239 W	517 W	660 W	745 W
900	287 W	621 W	792 W	894 W
1000	406 W	880 W	1 122 W	1 267 W
1100	406 W	880 W	1 122 W	1 267 W
1200	478 W	1 035 W	1 320 W	1 491 W
1300	525 W	1 138 W	1 452 W	1 640 W
1400	585 W	1 268 W	1 617 W	1 826 W
1500	645 W	1 397 W	1 782 W	2 012 W
1600	706 W	1 529 W	1 950 W	2 202 W
1700	706 W	1 529 W	1 950 W	2 202 W
1800	812 W	1 759 W	2 244 W	2 534 W
1900	885 W	1 917 W	2 445 W	2 761 W
2000	945 W	2 046 W	2 610 W	2 948 W
2100	992 W	2 150 W	2 742 W	3 097 W
2200	992 W	2 150 W	2 742 W	3 097 W
2300	1 112 W	2 409 W	3 072 W	3 469 W
2400	1 112 W	2 409 W	3 072 W	3 469 W
2500	1 183 W	2 564 W	3 270 W	3 693 W
2600	1 231 W	2 667 W	3 402 W	3 842 W
2700	1 279 W	2 771 W	3 534 W	3 991 W
2800	1 351 W	2 926 W	3 732 W	4 215 W
2900	1 411 W	3 058 W	3 901 W	4 405 W
3000	1 411 W	3 058 W	3 901 W	4 405 W
3200	1 591 W	3 446 W	4 396 W	4 964 W
3400	1 650 W	3 576 W	4 561 W	5 150 W
3600	1 817 W	3 938 W	5 023 W	5 672 W
3800	1 877 W	4 067 W	5 188 W	5 858 W
4000	1 985 W	4 300 W	5 485 W	6 193 W
4200	2 117 W	4 587 W	5 851 W	6 607 W
4400	2 223 W	4 817 W	6 145 W	6 939 W
4600	2 356 W	5 105 W	6 511 W	7 352 W
4800	2 404 W	5 208 W	6 643 W	7 501 W

Q[W] 55/45/20 °C (ΔT=30 °C)

Length L [mm]	Speed [-] / Heating output [W]			
	1	2	3	4 max.
700	102 W	221 W	282 W	319 W
800	136 W	295 W	376 W	425 W
900	164 W	354 W	452 W	510 W
1000	231 W	502 W	640 W	722 W
1100	231 W	502 W	640 W	722 W
1200	273 W	590 W	753 W	850 W
1300	299 W	649 W	828 W	935 W
1400	334 W	723 W	922 W	1 041 W
1500	368 W	796 W	1 016 W	1 147 W
1600	403 W	872 W	1 112 W	1 255 W
1700	403 W	872 W	1 112 W	1 255 W
1800	463 W	1 003 W	1 279 W	1 445 W
1900	505 W	1 093 W	1 394 W	1 574 W
2000	539 W	1 166 W	1 488 W	1 681 W
2100	566 W	1 226 W	1 563 W	1 766 W
2200	566 W	1 226 W	1 563 W	1 766 W
2300	634 W	1 373 W	1 751 W	1 978 W
2400	634 W	1 373 W	1 751 W	1 978 W
2500	674 W	1 462 W	1 864 W	2 105 W
2600	702 W	1 521 W	1 940 W	2 190 W
2700	729 W	1 580 W	2 015 W	2 275 W
2800	770 W	1 668 W	2 128 W	2 403 W
2900	804 W	1 743 W	2 224 W	2 511 W
3000	804 W	1 743 W	2 224 W	2 511 W
3200	907 W	1 965 W	2 506 W	2 830 W
3400	941 W	2 039 W	2 600 W	2 936 W
3600	1 036 W	2 245 W	2 864 W	3 234 W
3800	1 070 W	2 319 W	2 958 W	3 340 W
4000	1 132 W	2 452 W	3 127 W	3 531 W
4200	1 207 W	2 615 W	3 336 W	3 767 W
4400	1 267 W	2 746 W	3 503 W	3 956 W
4600	1 343 W	2 910 W	3 712 W	4 192 W
4800	1 371 W	2 969 W	3 787 W	4 276 W

75/65/20 °C → 75 °C inlet temperature, 65 °C outlet temp., 20 °C room temp. / **Output 90/70/20 °C** = ~ 1,22 x 75/65/20 °C / **Output 70/55/20 °C** = ~ 0,84 x 75/65/20 °C / Heating outputs in accordance with EN442 / Not listed heating output for lengths per 100 mm steps calculate linearly.

 **Acoustic pressure [dB(A)]**

Length L [mm]	Speed [-] / Acoustic pressure [dB(A)]			
	1	2	3	4 max.
700	< 20 dB(A)	20 dB(A)	25 dB(A)	29 dB(A)
800		30 dB(A)		
900		21 dB(A)	26 dB(A)	31 dB(A)
1000				
1100		22 dB(A)	27 dB(A)	32 dB(A)
1200				
1300				
1400				
1500		23 dB(A)	28 dB(A)	34 dB(A)
1600				
1700				
1800				
1900		24 dB(A)	29 dB(A)	35 dB(A)
2000				
2100				
2200				
2300	25 dB(A)	30 dB(A)	36 dB(A)	
2400				
2500				
2600				
2700	26 dB(A)	31 dB(A)	37 dB(A)	
2800				
2900				
3000				
3200	27 dB(A)	32 dB(A)	38 dB(A)	
3400				
3600				
3800				
4000	28 dB(A)	33 dB(A)	38 dB(A)	
4200				
4400				
4600				
4800	29 dB(A)	34 dB(A)		
	30 dB(A)	35 dB(A)		

Acoustic pressure level choose according to specific environment. More details on page 10

 **Fans input power [W]***

Length L [mm]	Speed [-] / Fans input power [W]*			
	1	2	3	4 max.
700	1 W	1 W	2 W	2 W
800	1 W	1 W	2 W	2 W
900	1 W	1 W	2 W	2 W
1000	2 W	2 W	2 W	3 W
1100	2 W	2 W	2 W	3 W
1200	2 W	3 W	3 W	4 W
1300	2 W	3 W	3 W	4 W
1400	3 W	3 W	4 W	5 W
1500	3 W	3 W	4 W	5 W
1600	3 W	3 W	4 W	5 W
1700	3 W	3 W	4 W	5 W
1800	3 W	3 W	4 W	5 W
1900	3 W	4 W	5 W	6 W
2000	4 W	5 W	6 W	7 W
2100	4 W	5 W	6 W	7 W
2200	4 W	5 W	6 W	7 W
2300	4 W	5 W	6 W	7 W
2400	4 W	5 W	6 W	7 W
2500	5 W	6 W	7 W	9 W
2600	5 W	6 W	7 W	9 W
2700	5 W	6 W	7 W	9 W
2800	5 W	6 W	7 W	9 W
2900	5 W	6 W	7 W	9 W
3000	5 W	6 W	7 W	9 W
3200	6 W	8 W	9 W	11 W
3400	6 W	8 W	9 W	11 W
3600	7 W	8 W	10 W	12 W
3800	7 W	9 W	11 W	13 W
4000	7 W	9 W	11 W	13 W
4200	7 W	9 W	11 W	13 W
4400	8 W	10 W	12 W	14 W
4600	8 W	10 W	12 W	15 W
4800	8 W	10 W	12 W	15 W

* Approximate fan input powers / **When using electrothermal actuator add in the trench heater's power 3 W** / Wiring of the trench heater → page 80

FRT 0080 0175

ECO & SAFE | VOLTAGE 24

TRENCH HEATER WITH FAN



- Flats, detached houses, offices, administrative buildings
- Narrow and low trench heater
- High heating output
- Continuous speed control
- Quiet operation
- Common electricity consumption **2 W/m**
- Using in dry environment



Technical data

Trench heater

Height	H = 80 mm
Width	W = 175 mm
Length	L = 700-4 800 mm in step 100 mm

Heat exchanger

Type	Al-Cu lamellar
Length	L- 295 mm
Connection thread	2xG1/2" inner

Working conditions

Max. temperature	110 °C
Max. overpressure	1 MPa (10 bar)
Protection	IP 20
Ambient conditions	Temp. T = +2 to +40 °C Humidity Rh = 20 to 70 %

Variants

Transverse grilles - rigid

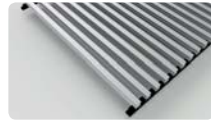

natur - anod. aluminium



bronze - anod. aluminium

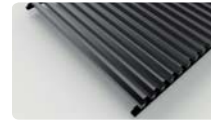

black - anod. aluminium

Peripheral ledge



(more on page 7)

- Low trench heaters are equipped with a non-rolling grille segment
- Only transverse grilles are delivered
- Colours natural, bronze, black

More possibilities and variants → page 6

Trench heater standard equipment

Trough	Galvanized steel trough with surface finish and black spray layer inside, black cover plates of connection
Heat exchanger	Al-Cu lamellar exchanger with air vent valve, black painted
Grille	Design walkable grille according the customer's choice
Ledge	Made of anodized aluminium, type and colour according the customer's choice
Fan	Modern tangential fan with 24 V DC EC motor with high efficiency, rotors protection
Assembly elements	Leveling screws for setting up the trough, mounting brackets
Manual	Manual for the progress of work during installation and user manual
Wiring	Electrical wiring diagram of the trench heaters
Mounting board	Cover and the spacer particle board for easy installation
Package	Transport package for protection against damage during transportation and handling

Accessories per order



Accessories details → page 11

Technical drawing

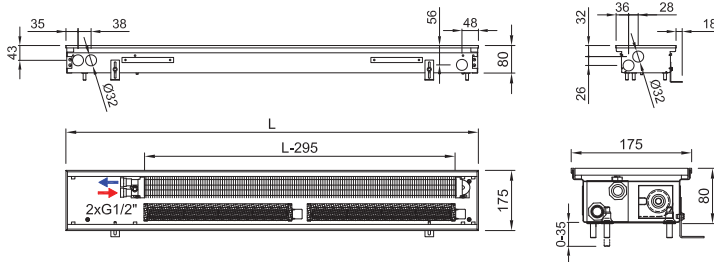

Connection to heating system

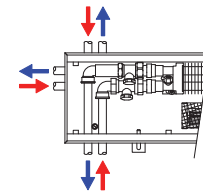

Electrothermal actuator can't be installed in the body of the trench heater due to limited internal space.

The hydraulic parameters of the heat exchanger → page 78

Code example: FRT 0080 0175 1700 C 35 J3 L - 5

Trench heater **FRT** H=80 mm, W= 175 mm, L=1 700 mm, „**C**“ Galvanized steel trough with black inside, heat exchanger and inner parts painted black, „**35**“ low black anodized aluminium grille, transverse, rigid, „**J3**“ peripheral ledge „**J**“, black anodized aluminium „**L**“ water connection at the left side (when installing the heat exchanger closer to the window, fans to the room), „**5**“ 24 V DC fans without controller (controller is not needed)

 **Trench heater heating output FRT 0080 0175**

Q[W] 75/65/20 °C (ΔT=50 °C)

Temperature exponent 1,1

Length L [mm]	Speed [-] / Heating output [W]			
	1	2	3	4 max.
700	94 W	235 W	291 W	347 W
800	126 W	313 W	388 W	463 W
900	151 W	375 W	466 W	556 W
1000	213 W	532 W	660 W	788 W
1100	213 W	532 W	660 W	788 W
1200	251 W	625 W	776 W	927 W
1300	276 W	688 W	854 W	1 019 W
1400	308 W	766 W	951 W	1 135 W
1500	339 W	844 W	1 048 W	1 251 W
1600	371 W	924 W	1 147 W	1 369 W
1700	371 W	924 W	1 147 W	1 369 W
1800	427 W	1 063 W	1 320 W	1 575 W
1900	465 W	1 159 W	1 438 W	1 716 W
2000	497 W	1 237 W	1 535 W	1 832 W
2100	522 W	1 299 W	1 613 W	1 925 W
2200	522 W	1 299 W	1 613 W	1 925 W
2300	584 W	1 456 W	1 807 W	2 157 W
2400	584 W	1 456 W	1 807 W	2 157 W
2500	622 W	1 549 W	1 923 W	2 296 W
2600	647 W	1 612 W	2 001 W	2 388 W
2700	672 W	1 674 W	2 079 W	2 481 W
2800	710 W	1 768 W	2 195 W	2 620 W
2900	742 W	1 848 W	2 294 W	2 738 W
3000	742 W	1 848 W	2 294 W	2 738 W
3200	836 W	2 083 W	2 585 W	3 085 W
3400	868 W	2 161 W	2 682 W	3 201 W
3600	955 W	2 380 W	2 954 W	3 526 W
3800	987 W	2 458 W	3 051 W	3 641 W
4000	1 043 W	2 598 W	3 226 W	3 850 W
4200	1 113 W	2 772 W	3 441 W	4 107 W
4400	1 169 W	2 911 W	3 614 W	4 313 W
4600	1 239 W	3 085 W	3 829 W	4 570 W
4800	1 264 W	3 147 W	3 907 W	4 663 W

Q[W] 55/45/20 °C (ΔT=30 °C)

Length L [mm]	Speed [-] / Heating output [W]			
	1	2	3	4 max.
700	54 W	134 W	166 W	198 W
800	72 W	178 W	221 W	264 W
900	86 W	214 W	266 W	317 W
1000	121 W	303 W	376 W	449 W
1100	121 W	303 W	376 W	449 W
1200	143 W	356 W	442 W	529 W
1300	157 W	392 W	487 W	581 W
1400	176 W	437 W	542 W	647 W
1500	193 W	481 W	597 W	713 W
1600	212 W	527 W	654 W	780 W
1700	212 W	527 W	654 W	780 W
1800	243 W	606 W	753 W	898 W
1900	265 W	661 W	820 W	978 W
2000	283 W	705 W	875 W	1 044 W
2100	298 W	741 W	920 W	1 097 W
2200	298 W	741 W	920 W	1 097 W
2300	333 W	830 W	1 030 W	1 230 W
2400	333 W	830 W	1 030 W	1 230 W
2500	355 W	883 W	1 096 W	1 309 W
2600	369 W	919 W	1 141 W	1 361 W
2700	383 W	954 W	1 185 W	1 414 W
2800	405 W	1 008 W	1 251 W	1 494 W
2900	423 W	1 054 W	1 308 W	1 561 W
3000	423 W	1 054 W	1 308 W	1 561 W
3200	477 W	1 188 W	1 474 W	1 759 W
3400	495 W	1 232 W	1 529 W	1 825 W
3600	544 W	1 357 W	1 684 W	2 010 W
3800	563 W	1 401 W	1 739 W	2 076 W
4000	595 W	1 481 W	1 839 W	2 195 W
4200	635 W	1 580 W	1 962 W	2 341 W
4400	666 W	1 660 W	2 060 W	2 459 W
4600	706 W	1 759 W	2 183 W	2 605 W
4800	721 W	1 794 W	2 227 W	2 658 W

75/65/20 °C → 75 °C inlet temperature, 65 °C outlet temp., 20 °C room temp. / Output 90/70/20 °C = ~ 1,22 x 75/65/20 °C / Output 70/55/20 °C = ~ 0,84 x 75/65/20 °C / Heating outputs in accordance with EN442 / Not listed heating output for lengths per 100 mm steps calculate linearly.

 **Acoustic pressure [dB(A)]**

Length L [mm]	Speed [-] / Acoustic pressure [dB(A)]			
	1	2	3	4 max.
700	< 20 dB(A)	20 dB(A)	25 dB(A)	29 dB(A)
800		21 dB(A)	26 dB(A)	30 dB(A)
900				31 dB(A)
1000				
1100				
1200		22 dB(A)	27 dB(A)	32 dB(A)
1300				33 dB(A)
1400				
1500				
1600		23 dB(A)	28 dB(A)	34 dB(A)
1700				
1800				
1900		24 dB(A)	29 dB(A)	35 dB(A)
2000				
2100				
2200		25 dB(A)	30 dB(A)	36 dB(A)
2300				
2400				
2500		26 dB(A)	31 dB(A)	37 dB(A)
2600				
2700				
2800		27 dB(A)	32 dB(A)	38 dB(A)
2900				
3000				
3200	28 dB(A)	33 dB(A)	38 dB(A)	
3400				
3600				
3800	29 dB(A)	34 dB(A)	38 dB(A)	
4000				
4200				
4400	30 dB(A)	35 dB(A)	38 dB(A)	
4600				
4800				

Acoustic pressure level choose according to specific environment. More details on page 10

 **Fans input power [W]***

Length L [mm]	Speed [-] / Fans input power [W]*			
	1	2	3	4 max.
700	1 W	1 W	2 W	2 W
800	1 W	1 W	2 W	2 W
900	1 W	1 W	2 W	2 W
1000	2 W	2 W	2 W	3 W
1100	2 W	2 W	2 W	3 W
1200	2 W	3 W	3 W	4 W
1300	2 W	3 W	3 W	4 W
1400	3 W	3 W	4 W	5 W
1500	3 W	3 W	4 W	5 W
1600	3 W	3 W	4 W	5 W
1700	3 W	3 W	4 W	5 W
1800	3 W	3 W	4 W	5 W
1900	3 W	4 W	5 W	6 W
2000	4 W	5 W	6 W	7 W
2100	4 W	5 W	6 W	7 W
2200	4 W	5 W	6 W	7 W
2300	4 W	5 W	6 W	7 W
2400	4 W	5 W	6 W	7 W
2500	5 W	6 W	7 W	9 W
2600	5 W	6 W	7 W	9 W
2700	5 W	6 W	7 W	9 W
2800	5 W	6 W	7 W	9 W
2900	5 W	6 W	7 W	9 W
3000	5 W	6 W	7 W	9 W
3200	6 W	8 W	9 W	11 W
3400	6 W	8 W	9 W	11 W
3600	7 W	8 W	10 W	12 W
3800	7 W	9 W	11 W	13 W
4000	7 W	9 W	11 W	13 W
4200	7 W	9 W	11 W	13 W
4400	8 W	10 W	12 W	14 W
4600	8 W	10 W	12 W	15 W
4800	8 W	10 W	12 W	15 W

* Approximate fan input powers / When using electrothermal actuator add in the trench heater's power 3 W / Wiring of the trench heater → page 80

FRT 0080 0200

ECO & SAFE | **VOLTAGE 24**

TRENCH HEATER WITH FAN



- Flats, detached houses, offices, administrative buildings
- Small universal trench heater
- High heating output
- Continuous speed control
- Quiet operation
- Common electricity consumption **2 W/m**
- Using in dry environment



Technical data

Trench heater

Height	H = 80 mm
Width	W = 200 mm
Length	L = 700-4 800 mm in step 100 mm

Heat exchanger

Type	Al-Cu lamellar
Length	L- 295 mm
Connection thread	2xG1/2" inner

Working conditions

Max. temperature	110 °C
Max. overpressure	1 MPa (10 bar)
Protection	IP 20
Ambient conditions	Temp. T = +2 to +40 °C Humidity Rh = 20 to 70 %

Variants

Transverse grilles - rigid

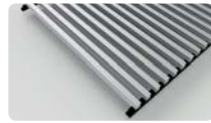

natur - anod. aluminium



bronze - anod. aluminium

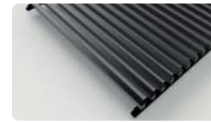

black - anod. aluminium

Peripheral ledge



(more on page 7)

- Low trench heaters are equipped with a non-rolling grille segment
- Only transverse grilles are delivered
- Colours natural, bronze, black

More possibilities and variants → page 6

Trench heater standard equipment

Trough	Galvanized steel trough with surface finish and black spray layer inside, black cover plates of connection
Heat exchanger	Al-Cu lamellar exchanger with air vent valve, black painted
Grille	Design walkable grille according the customer's choice
Ledge	Made of anodized aluminium, type and colour according the customer's choice
Fan	Modern tangential fan with 24 V DC EC motor with high efficiency, rotors protection
Assembly elements	Leveling screws for setting up the trough, mounting brackets
Manual	Manual for the progress of work during installation and user manual
Wiring	Electrical wiring diagram of the trench heaters
Mounting board	Cover and the spacer particle board for easy installation
Package	Transport package for protection against damage during transportation and handling

Accessories per order

	Room thermostat		Power supply
	Electrothermal actuator		Thermostatic valve
	Lockshield valve		

Accessories details → page 11

Technical drawing

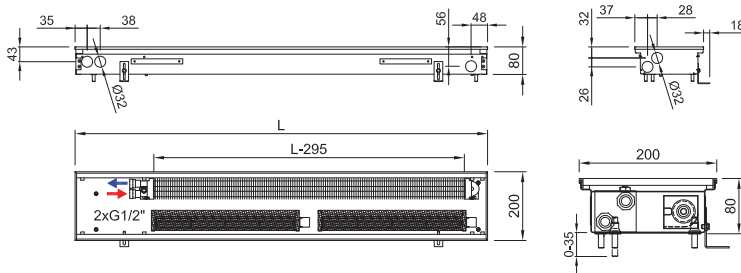

Connection to heating system

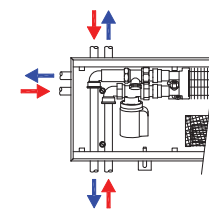

The hydraulic parameters of the heat exchanger → page 78

Code example: FRT 0080 0200 1900 C 15 L1 L - 5

Trench heater **FRT** H=**80** mm, W=**200** mm, L=**1 900** mm, „**C**“ Galvanized steel trough with black inside, heat exchanger and inner parts painted black, „**15**“ Low natural anodized aluminium grille, transverse, rigid, „**L1**“ peripheral ledge „L“ with an overlap, natur anodized aluminium „L“ water connection at the left side (when installing the heat exchanger closer to the window, fans to the room), „**5**“ 24 V DC fans without controller (controller is not needed)

 **Trench heater heating output FRT 0080 0200**

Q[W] 75/65/20 °C (ΔT=50 °C)

Temperature exponent 1,1

Length L [mm]	Speed [-] / Heating output [W]			
	1	2	3	4 max.
700	154 W	250 W	310 W	371 W
800	205 W	334 W	414 W	494 W
900	246 W	400 W	496 W	593 W
1000	349 W	567 W	703 W	840 W
1100	349 W	567 W	703 W	840 W
1200	410 W	667 W	827 W	988 W
1300	451 W	734 W	910 W	1 087 W
1400	502 W	817 W	1 013 W	1 210 W
1500	554 W	901 W	1 117 W	1 334 W
1600	606 W	986 W	1 222 W	1 460 W
1700	606 W	986 W	1 222 W	1 460 W
1800	697 W	1 134 W	1 406 W	1 680 W
1900	760 W	1 236 W	1 532 W	1 831 W
2000	811 W	1 320 W	1 636 W	1 954 W
2100	852 W	1 386 W	1 718 W	2 053 W
2200	852 W	1 386 W	1 718 W	2 053 W
2300	955 W	1 553 W	1 925 W	2 300 W
2400	955 W	1 553 W	1 925 W	2 300 W
2500	1 016 W	1 653 W	2 049 W	2 448 W
2600	1 057 W	1 720 W	2 132 W	2 547 W
2700	1 098 W	1 787 W	2 214 W	2 646 W
2800	1 160 W	1 887 W	2 339 W	2 794 W
2900	1 212 W	1 972 W	2 444 W	2 920 W
3000	1 212 W	1 972 W	2 444 W	2 920 W
3200	1 366 W	2 222 W	2 754 W	3 291 W
3400	1 417 W	2 306 W	2 858 W	3 414 W
3600	1 561 W	2 539 W	3 147 W	3 760 W
3800	1 612 W	2 623 W	3 250 W	3 883 W
4000	1 704 W	2 773 W	3 436 W	4 106 W
4200	1 818 W	2 958 W	3 666 W	4 380 W
4400	1 909 W	3 106 W	3 850 W	4 600 W
4600	2 023 W	3 292 W	4 080 W	4 874 W
4800	2 064 W	3 358 W	4 162 W	4 973 W

Q[W] 55/45/20 °C (ΔT=30 °C)

Length L [mm]	Speed [-] / Heating output [W]			
	1	2	3	4 max.
700	88 W	143 W	177 W	212 W
800	117 W	190 W	236 W	282 W
900	140 W	228 W	283 W	338 W
1000	199 W	323 W	401 W	479 W
1100	199 W	323 W	401 W	479 W
1200	234 W	380 W	471 W	563 W
1300	257 W	418 W	519 W	620 W
1400	286 W	466 W	578 W	690 W
1500	316 W	514 W	637 W	761 W
1600	345 W	562 W	697 W	832 W
1700	345 W	562 W	697 W	832 W
1800	397 W	647 W	802 W	958 W
1900	433 W	705 W	873 W	1 044 W
2000	462 W	753 W	933 W	1 114 W
2100	486 W	790 W	979 W	1 170 W
2200	486 W	790 W	979 W	1 170 W
2300	544 W	885 W	1 097 W	1 311 W
2400	544 W	885 W	1 097 W	1 311 W
2500	579 W	942 W	1 168 W	1 396 W
2600	603 W	981 W	1 215 W	1 452 W
2700	626 W	1 019 W	1 262 W	1 509 W
2800	661 W	1 076 W	1 334 W	1 593 W
2900	691 W	1 124 W	1 393 W	1 665 W
3000	691 W	1 124 W	1 393 W	1 665 W
3200	779 W	1 267 W	1 570 W	1 876 W
3400	808 W	1 315 W	1 629 W	1 946 W
3600	890 W	1 448 W	1 794 W	2 144 W
3800	919 W	1 495 W	1 853 W	2 214 W
4000	971 W	1 581 W	1 959 W	2 341 W
4200	1 036 W	1 686 W	2 090 W	2 497 W
4400	1 088 W	1 771 W	2 195 W	2 623 W
4600	1 153 W	1 877 W	2 326 W	2 779 W
4800	1 177 W	1 914 W	2 373 W	2 835 W

75/65/20 °C → 75 °C inlet temperature, 65 °C outlet temp., 20 °C room temp. / Output 90/70/20 °C = ~ 1,22 x 75/65/20 °C / Output 70/55/20 °C = ~ 0,84 x 75/65/20 °C / Heating outputs in accordance with EN442 / Not listed heating outputs for lengths per 100 mm steps calculate linearly.

 **Acoustic pressure [dB(A)]**

Length L [mm]	Speed [-] / Acoustic pressure [dB(A)]					
	1	2	3	4 max.		
700	< 20 dB(A)	20 dB(A)	25 dB(A)	29 dB(A)		
800		30 dB(A)				
900		21 dB(A)	26 dB(A)	31 dB(A)		
1000						
1100		22 dB(A)	27 dB(A)	32 dB(A)		
1200						
1300						
1400						
1500		23 dB(A)	28 dB(A)	34 dB(A)		
1600						
1700						
1800						
1900						
2000						
2100		24 dB(A)	29 dB(A)	35 dB(A)		
2200						
2300						
2400						
2500	25 dB(A)				30 dB(A)	36 dB(A)
2600						
2700						
2800						
2900						
3000						
3200	26 dB(A)	31 dB(A)	37 dB(A)			
3400						
3600						
3800						
4000	27 dB(A)	32 dB(A)	38 dB(A)			
4200						
4400						
4600						
4800						
4800						

Acoustic pressure level choose according to specific environment. More details on page 10

 **Fans input power [W]***

Length L [mm]	Speed [-] / Fans input power [W]*			
	1	2	3	4 max.
700	1 W	1 W	2 W	2 W
800	1 W	1 W	2 W	2 W
900	1 W	1 W	2 W	2 W
1000	2 W	2 W	2 W	3 W
1100	2 W	2 W	2 W	3 W
1200	2 W	3 W	3 W	4 W
1300	2 W	3 W	3 W	4 W
1400	3 W	3 W	4 W	5 W
1500	3 W	3 W	4 W	5 W
1600	3 W	3 W	4 W	5 W
1700	3 W	3 W	4 W	5 W
1800	3 W	3 W	4 W	5 W
1900	3 W	4 W	5 W	6 W
2000	4 W	5 W	6 W	7 W
2100	4 W	5 W	6 W	7 W
2200	4 W	5 W	6 W	7 W
2300	4 W	5 W	6 W	7 W
2400	4 W	5 W	6 W	7 W
2500	5 W	6 W	7 W	9 W
2600	5 W	6 W	7 W	9 W
2700	5 W	6 W	7 W	9 W
2800	5 W	6 W	7 W	9 W
2900	5 W	6 W	7 W	9 W
3000	5 W	6 W	7 W	9 W
3200	6 W	8 W	9 W	11 W
3400	6 W	8 W	9 W	11 W
3600	7 W	8 W	10 W	12 W
3800	7 W	9 W	11 W	13 W
4000	7 W	9 W	11 W	13 W
4200	7 W	9 W	11 W	13 W
4400	8 W	10 W	12 W	14 W
4600	8 W	10 W	12 W	15 W
4800	8 W	10 W	12 W	15 W

* Approximate fan input powers / When using electrothermal actuator add in the trench heater's power 3 W / Wiring of the trench heater → page 80

FRT 0080 0250

ECO & SAFE | **VOLTAGE 24**

TRENCH HEATER WITH FAN



- Flats, detached houses, offices, administrative buildings
- Small universal trench heater
- High heating output
- Continuous speed control
- Quiet operation
- Common electricity consumption **2 W/m**
- Using in dry environment



Technical data

Trench heater

Height	H = 80 mm
Width	W = 250 mm
Length	L = 700-4 800 mm in step 100 mm

Heat exchanger

Type	Al-Cu lamellar
Length	L-295 mm
Connection thread	2x G1/2" inner

Working conditions

Max. temperature	110 °C
Max. overpressure	1 MPa (10 bar)
Protection	IP 20
Ambient conditions	Temp. T = +2 to +40 °C Humidity Rh = 20 to 70%

Variants

Transverse roll-up grilles

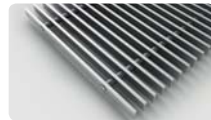

natur - anod. aluminium



bronze - anod. aluminium



black - anod. aluminium

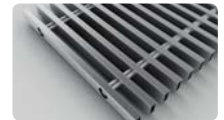

stainless*



natur beech - wooden



stained beech - wooden



natur oak - wooden



stained oak - wooden

Linear non-rolling grilles



natur - anod. aluminium



bronze - anod. aluminium



black - anod. aluminium

Peripheral ledges



(more on page 7)

More possibilities and variants → page 6 / *stainless grilles surcharge

Trench heater standard equipment

Trough	Galvanized steel trough with surface finish and black spray layer inside, black cover plates of connection
Heat exchanger	Al-Cu lamellar exchanger with air vent valve, black painted
Grille	Design walkable grille according the customer's choice*
Ledge	Made of anodized aluminium, type and colour according the customer's choice
Fan	Modern tangential fan with 24 V DC EC motor with high efficiency, rotors protection
Assembly elements	Leveling screws for setting up the trough, mounting brackets
Manual	Manual for the progress of work during installation and user manual
Wiring	Electrical wiring diagram of the trench heaters
Mounting board	Cover and the spacer particle board for easy installation
Package	Transport package for protection against damage during transportation and handling

* stainless grille surcharge

Accessories per order

	Room thermostat		Power supply
	Electrothermal actuator		Thermostatic valve
	Lockshield valve		

Accessories details → page 11

Technical drawing

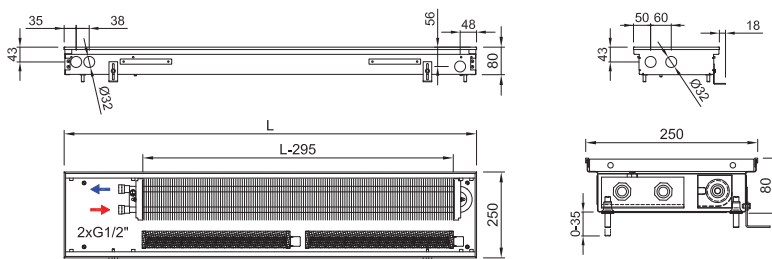

Connection to heating system

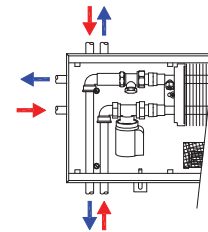

The hydraulic parameters of the heat exchanger → page 78

Code example: FRT 0080 0250 0900 C 12 J1 L - 5

Trench heater FRT H=80 mm, W=250 mm, L=900 mm, „C“ Galvanized steel trough with black inside, heat exchanger and inner parts painted black, „12“ natur anodized aluminium grille, linear, rigid „J1“ peripheral ledge „J“, natur anodized aluminium, „L“ water connection at the left side (when installing the heat exchanger closer to the window, fans to the room), „5“ 24 V DC fans without controller (controller is not needed)

Trench heater heating output FRT 0080 0250

Q[W] 75/65/20 °C (ΔT=50 °C)

Temperature exponent 1,1

Length L [mm]	Speed [-] / Heating output [W]			
	1	2	3	4 max.
700	163 W	363 W	479 W	535 W
800	218 W	483 W	639 W	714 W
900	262 W	580 W	766 W	857 W
1000	371 W	822 W	1 086 W	1 213 W
1100	371 W	822 W	1 086 W	1 213 W
1200	436 W	967 W	1 277 W	1 428 W
1300	479 W	1 064 W	1 405 W	1 570 W
1400	534 W	1 184 W	1 565 W	1 749 W
1500	588 W	1 305 W	1 724 W	1 927 W
1600	644 W	1 429 W	1 887 W	2 109 W
1700	644 W	1 429 W	1 887 W	2 109 W
1800	741 W	1 644 W	2 172 W	2 427 W
1900	808 W	1 791 W	2 366 W	2 645 W
2000	862 W	1 912 W	2 526 W	2 823 W
2100	906 W	2 009 W	2 654 W	2 966 W
2200	906 W	2 009 W	2 654 W	2 966 W
2300	1 015 W	2 251 W	2 973 W	3 323 W
2400	1 015 W	2 251 W	2 973 W	3 323 W
2500	1 080 W	2 396 W	3 165 W	3 537 W
2600	1 124 W	2 492 W	3 292 W	3 680 W
2700	1 167 W	2 589 W	3 420 W	3 822 W
2800	1 233 W	2 734 W	3 612 W	4 036 W
2900	1 288 W	2 857 W	3 775 W	4 218 W
3000	1 288 W	2 857 W	3 775 W	4 218 W
3200	1 452 W	3 220 W	4 254 W	4 754 W
3400	1 506 W	3 341 W	4 413 W	4 932 W
3600	1 659 W	3 679 W	4 860 W	5 432 W
3800	1 713 W	3 800 W	5 020 W	5 610 W
4000	1 811 W	4 018 W	5 307 W	5 932 W
4200	1 932 W	4 286 W	5 662 W	6 328 W
4400	2 029 W	4 501 W	5 946 W	6 645 W
4600	2 150 W	4 769 W	6 301 W	7 041 W
4800	2 194 W	4 866 W	6 428 W	7 184 W

Q[W] 55/45/20 °C (ΔT=30 °C)

Length L [mm]	Speed [-] / Heating output [W]			
	1	2	3	4 max.
700	93 W	207 W	273 W	305 W
800	124 W	275 W	364 W	407 W
900	149 W	331 W	437 W	489 W
1000	212 W	469 W	619 W	692 W
1100	212 W	469 W	619 W	692 W
1200	249 W	551 W	728 W	814 W
1300	273 W	607 W	801 W	895 W
1400	304 W	675 W	892 W	997 W
1500	335 W	744 W	983 W	1 099 W
1600	367 W	815 W	1 076 W	1 202 W
1700	367 W	815 W	1 076 W	1 202 W
1800	422 W	937 W	1 238 W	1 384 W
1900	461 W	1 021 W	1 349 W	1 508 W
2000	491 W	1 090 W	1 440 W	1 609 W
2100	517 W	1 145 W	1 513 W	1 691 W
2200	517 W	1 145 W	1 513 W	1 691 W
2300	579 W	1 283 W	1 695 W	1 895 W
2400	579 W	1 283 W	1 695 W	1 895 W
2500	616 W	1 366 W	1 804 W	2 017 W
2600	641 W	1 421 W	1 877 W	2 098 W
2700	665 W	1 476 W	1 950 W	2 179 W
2800	703 W	1 559 W	2 059 W	2 301 W
2900	734 W	1 629 W	2 152 W	2 405 W
3000	734 W	1 629 W	2 152 W	2 405 W
3200	828 W	1 836 W	2 425 W	2 710 W
3400	859 W	1 905 W	2 516 W	2 812 W
3600	946 W	2 097 W	2 771 W	3 097 W
3800	977 W	2 166 W	2 862 W	3 198 W
4000	1 032 W	2 291 W	3 026 W	3 382 W
4200	1 101 W	2 444 W	3 228 W	3 608 W
4400	1 157 W	2 566 W	3 390 W	3 788 W
4600	1 226 W	2 719 W	3 592 W	4 014 W
4800	1 251 W	2 774 W	3 665 W	4 096 W

75/65/20 °C → 75 °C inlet temperature, 65 °C outlet temp., 20 °C room temp. / Output 90/70/20 °C = ~ 1,22 x 75/65/20 °C / Output 70/55/20 °C = ~ 0,84 x 75/65/20 °C / Heating outputs in accordance with EN442 / Not listed heating outputs for lengths per 100 mm steps calculate linearly.

Acoustic pressure [dB(A)]

Length L [mm]	Speed [-] / Acoustic pressure [dB(A)]			
	1	2	3	4 max.
700	< 20 dB(A)	20 dB(A)	25 dB(A)	29 dB(A)
800		20 dB(A)	25 dB(A)	30 dB(A)
900		21 dB(A)	26 dB(A)	31 dB(A)
1000		21 dB(A)	26 dB(A)	
1100		22 dB(A)	27 dB(A)	32 dB(A)
1200				
1300				
1400				
1500		23 dB(A)	28 dB(A)	33 dB(A)
1600				
1700				
1800				
1900	24 dB(A)	29 dB(A)	34 dB(A)	
2000				
2100				
2200				
2300	25 dB(A)	30 dB(A)	35 dB(A)	
2400				
2500				
2600				
2700	26 dB(A)	31 dB(A)	36 dB(A)	
2800				
2900				
3000				
3200	27 dB(A)	32 dB(A)	37 dB(A)	
3400				
3600				
3800				
4000	28 dB(A)	33 dB(A)	38 dB(A)	
4200				
4400				
4600				
4800	29 dB(A)	34 dB(A)	38 dB(A)	
	30 dB(A)	35 dB(A)		

Acoustic pressure level choose according to specific environment. More details on page 10

Fans input power [W]*

Length L [mm]	Speed [-] / Fans input power [W]*			
	1	2	3	4 max.
700	1 W	1 W	2 W	2 W
800	1 W	1 W	2 W	2 W
900	1 W	1 W	2 W	2 W
1000	2 W	2 W	2 W	3 W
1100	2 W	2 W	2 W	3 W
1200	2 W	3 W	3 W	4 W
1300	2 W	3 W	3 W	4 W
1400	3 W	3 W	4 W	5 W
1500	3 W	3 W	4 W	5 W
1600	3 W	3 W	4 W	5 W
1700	3 W	3 W	4 W	5 W
1800	3 W	3 W	4 W	5 W
1900	3 W	4 W	5 W	6 W
2000	4 W	5 W	6 W	7 W
2100	4 W	5 W	6 W	7 W
2200	4 W	5 W	6 W	7 W
2300	4 W	5 W	6 W	7 W
2400	4 W	5 W	6 W	7 W
2500	5 W	6 W	7 W	9 W
2600	5 W	6 W	7 W	9 W
2700	5 W	6 W	7 W	9 W
2800	5 W	6 W	7 W	9 W
2900	5 W	6 W	7 W	9 W
3000	5 W	6 W	7 W	9 W
3200	6 W	8 W	9 W	11 W
3400	6 W	8 W	9 W	11 W
3600	7 W	8 W	10 W	12 W
3800	7 W	9 W	11 W	13 W
4000	7 W	9 W	11 W	13 W
4200	7 W	9 W	11 W	13 W
4400	8 W	10 W	12 W	14 W
4600	8 W	10 W	12 W	15 W
4800	8 W	10 W	12 W	15 W

* Approximate fan input powers / When using electrothermal actuator add in the trench heater's power 3 W / Wiring of the trench heater → page 80

FRT 0080 0300

ECO & SAFE | VOLTAGE 24

TRENCH HEATER WITH FAN



- Flats, detached houses, offices, administrative buildings
- Low trench heater with a good heating output
- High heating output
- Continuous speed control
- Quiet operation
- Common electricity consumption **2 W/m**
- Using in dry environment



Technical data

Trench heater

Height	H = 80 mm
Width	W = 300 mm
Length	L = 700-4 800 mm in step 100 mm

Heat exchanger

Type	Al-Cu lamellar
Length	L-295 mm
Connection thread	2xG1/2" inner

Working conditions

Max. temperature	110 °C
Max. overpressure	1 MPa (10 bar)
Protection	IP 20
Ambient conditions	Temp. T = +2 to +40 °C Humidity Rh = 20 to 70%

Variants

Transverse roll-up grilles



natur - anod. aluminium



bronze - anod. aluminium



black - anod. aluminium

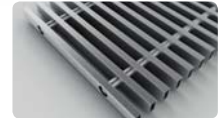

stainless



natur beech - wooden



stained beech - wooden



natur oak - wooden



stained oak - wooden

Linear non-rolling grilles



natur - anod. aluminium



bronze - anod. aluminium



black - anod. aluminium

Peripheral ledges



(more on page 7)

More possibilities and variants → page 6

Trench heater standard equipment

Trough	Galvanized steel trough with surface finish and black spray layer inside, black cover plates of connection
Heat exchanger	Al-Cu lamellar exchanger with air vent valve, black painted
Grille	Design walkable grille according the customer's choice*
Ledge	Made of anodized aluminium, type and colour according the customer's choice
Fan	Modern tangential fan with 24 V DC EC motor with high efficiency, rotors protection
Assembly elements	Leveling screws for setting up the trough, mounting brackets
Manual	Manual for the progress of work during installation and user manual
Wiring	Electrical wiring diagram of the trench heaters
Mounting board	Cover and the spacer particle board for easy installation
Package	Transport package for protection against damage during transportation and handling

*stainless grilles surcharge

Accessories per order

	Room thermostat		Power supply
	Electrothermal actuator		Thermostatic valve
	Lockshield valve		

Accessories details → page 11

Technical drawing

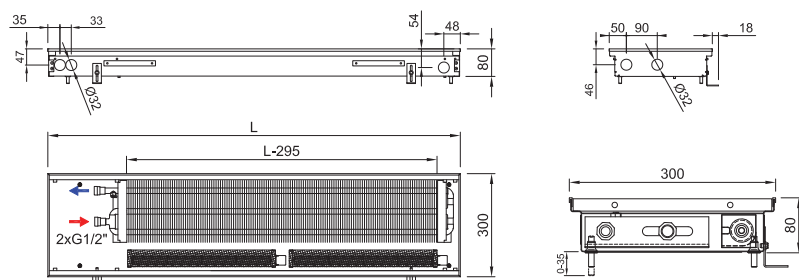

Connection to heating system

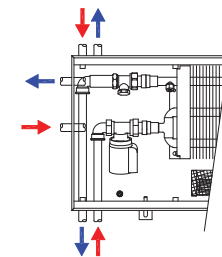

The hydraulic parameters of the heat exchanger → page

Code example: FRT 0080 0300 2200 C 21 J2 R - 5

Trench heater FRT H= 80 mm, W= 300 mm, L= 2 200 mm, „C“ Galvanized steel trough with black inside, heat exchanger and inner parts painted black, „21“ bronze anodized aluminium grille, transverse, roll-up „J2“ peripheral ledge „J“, bronze anodized aluminium, „R“ water connection at the right side (when installing the heat exchanger closer to the window, fans to the room), „5“ 24 V DC fans without controller (controller is not needed)

 **Trench heater heating output FRT 0080 0300**

Q[W] 75/65/20 °C (ΔT=50 °C)

Temperature exponent 1,1

Length L [mm]	Speed [-] / Heating output [W]			
	1	2	3	4 max.
700	190 W	416 W	532 W	612 W
800	253 W	555 W	709 W	816 W
900	304 W	666 W	851 W	979 W
1000	430 W	943 W	1 206 W	1 387 W
1100	430 W	943 W	1 206 W	1 387 W
1200	506 W	1 110 W	1 419 W	1 632 W
1300	556 W	1 221 W	1 561 W	1 795 W
1400	620 W	1 360 W	1 738 W	1 999 W
1500	683 W	1 498 W	1 915 W	2 203 W
1600	747 W	1 640 W	2 096 W	2 411 W
1700	747 W	1 640 W	2 096 W	2 411 W
1800	860 W	1 887 W	2 412 W	2 774 W
1900	937 W	2 056 W	2 628 W	3 023 W
2000	1 000 W	2 195 W	2 806 W	3 227 W
2100	1 051 W	2 306 W	2 948 W	3 390 W
2200	1 051 W	2 306 W	2 948 W	3 390 W
2300	1 177 W	2 583 W	3 302 W	3 798 W
2400	1 177 W	2 583 W	3 302 W	3 798 W
2500	1 253 W	2 750 W	3 515 W	4 043 W
2600	1 304 W	2 861 W	3 657 W	4 206 W
2700	1 355 W	2 972 W	3 799 W	4 369 W
2800	1 430 W	3 138 W	4 012 W	4 614 W
2900	1 495 W	3 280 W	4 193 W	4 822 W
3000	1 495 W	3 280 W	4 193 W	4 822 W
3200	1 685 W	3 696 W	4 725 W	5 434 W
3400	1 748 W	3 835 W	4 902 W	5 638 W
3600	1 925 W	4 223 W	5 399 W	6 209 W
3800	1 988 W	4 362 W	5 576 W	6 413 W
4000	2 102 W	4 611 W	5 895 W	6 780 W
4200	2 242 W	4 919 W	6 289 W	7 233 W
4400	2 355 W	5 166 W	6 605 W	7 596 W
4600	2 495 W	5 474 W	6 998 W	8 049 W
4800	2 546 W	5 585 W	7 140 W	8 212 W

Q[W] 55/45/20 °C (ΔT=30 °C)

Length L [mm]	Speed [-] / Heating output [W]			
	1	2	3	4 max.
700	108 W	237 W	303 W	349 W
800	144 W	316 W	404 W	465 W
900	173 W	380 W	485 W	558 W
1000	245 W	538 W	688 W	791 W
1100	245 W	538 W	688 W	791 W
1200	288 W	633 W	809 W	930 W
1300	317 W	696 W	890 W	1 023 W
1400	353 W	775 W	991 W	1 140 W
1500	389 W	854 W	1 092 W	1 256 W
1600	426 W	935 W	1 195 W	1 375 W
1700	426 W	935 W	1 195 W	1 375 W
1800	490 W	1 076 W	1 375 W	1 582 W
1900	534 W	1 172 W	1 498 W	1 723 W
2000	570 W	1 251 W	1 600 W	1 840 W
2100	599 W	1 315 W	1 681 W	1 933 W
2200	599 W	1 315 W	1 681 W	1 933 W
2300	671 W	1 473 W	1 883 W	2 165 W
2400	671 W	1 473 W	1 883 W	2 165 W
2500	714 W	1 568 W	2 004 W	2 305 W
2600	743 W	1 631 W	2 085 W	2 398 W
2700	773 W	1 694 W	2 166 W	2 491 W
2800	815 W	1 789 W	2 287 W	2 631 W
2900	852 W	1 870 W	2 391 W	2 749 W
3000	852 W	1 870 W	2 391 W	2 749 W
3200	961 W	2 107 W	2 694 W	3 098 W
3400	997 W	2 186 W	2 795 W	3 214 W
3600	1 097 W	2 408 W	3 078 W	3 540 W
3800	1 133 W	2 487 W	3 179 W	3 656 W
4000	1 198 W	2 629 W	3 361 W	3 865 W
4200	1 278 W	2 804 W	3 585 W	4 124 W
4400	1 343 W	2 945 W	3 766 W	4 331 W
4600	1 422 W	3 121 W	3 990 W	4 589 W
4800	1 452 W	3 184 W	4 071 W	4 682 W

75/65/20 °C → 75 °C inlet temperature, 65 °C outlet temp., 20 °C room temp. / **Output 90/70/20 °C** = ~ 1,22 x 75/65/20 °C / **Output 70/55/20 °C** = ~ 0,84 x 75/65/20 °C / Heating outputs in accordance with EN442 / Not listed heating outputs for lengths per 100 mm steps calculate linearly.

 **Acoustic pressure [dB(A)]**

Length L [mm]	Speed [-] / Acoustic pressure [dB(A)]			
	1	2	3	4 max.
700	< 20 dB(A)	20 dB(A)	25 dB(A)	29 dB(A)
800		30 dB(A)		
900		21 dB(A)	26 dB(A)	31 dB(A)
1000				
1100		22 dB(A)	27 dB(A)	32 dB(A)
1200				
1300				
1400				
1500		23 dB(A)	28 dB(A)	33 dB(A)
1600				
1700				
1800				
1900		24 dB(A)	29 dB(A)	34 dB(A)
2000				
2100				
2200				
2300	25 dB(A)	30 dB(A)	35 dB(A)	
2400				
2500				
2600				
2700	26 dB(A)	31 dB(A)	36 dB(A)	
2800				
2900				
3000				
3200	27 dB(A)	32 dB(A)	37 dB(A)	
3400				
3600				
3800				
4000	28 dB(A)	33 dB(A)	38 dB(A)	
4200				
4400				
4600				
4800	29 dB(A)	34 dB(A)		
	30 dB(A)	35 dB(A)		

Acoustic pressure level choose according to specific environment. More details on page 10

 **Fans input power [W]***

Length L [mm]	Speed [-] / Fans input power [W]*			
	1	2	3	4 max.
700	1 W	1 W	2 W	2 W
800	1 W	1 W	2 W	2 W
900	1 W	1 W	2 W	2 W
1000	2 W	2 W	2 W	3 W
1100	2 W	2 W	2 W	3 W
1200	2 W	3 W	3 W	4 W
1300	2 W	3 W	3 W	4 W
1400	3 W	3 W	4 W	5 W
1500	3 W	3 W	4 W	5 W
1600	3 W	3 W	4 W	5 W
1700	3 W	3 W	4 W	5 W
1800	3 W	3 W	4 W	5 W
1900	3 W	4 W	5 W	6 W
2000	4 W	5 W	6 W	7 W
2100	4 W	5 W	6 W	7 W
2200	4 W	5 W	6 W	7 W
2300	4 W	5 W	6 W	7 W
2400	4 W	5 W	6 W	7 W
2500	5 W	6 W	7 W	9 W
2600	5 W	6 W	7 W	9 W
2700	5 W	6 W	7 W	9 W
2800	5 W	6 W	7 W	9 W
2900	5 W	6 W	7 W	9 W
3000	5 W	6 W	7 W	9 W
3200	6 W	8 W	9 W	11 W
3400	6 W	8 W	9 W	11 W
3600	7 W	8 W	10 W	12 W
3800	7 W	9 W	11 W	13 W
4000	7 W	9 W	11 W	13 W
4200	7 W	9 W	11 W	13 W
4400	8 W	10 W	12 W	14 W
4600	8 W	10 W	12 W	15 W
4800	8 W	10 W	12 W	15 W

* Approximate fan input powers / **When using electrothermal actuator add in the trench heater's power 3 W** / Wiring of the trench heater → page 80

FRT 0090 0175

ECO & SAFE | VOLTAGE 24

TRENCH HEATER WITH FAN



- Flats, detached houses, offices, administrative buildings
- Small narrow trench heater
- High heating output
- Continuous speed control
- Quiet operation
- Common electricity consumption **2 W/m**
- Using in dry environment



Technical data

Trench heater

Height	H = 90 mm
Width	W = 175 mm
Length	L = 700-4 800 mm in step 100 mm

Heat exchanger

Type	Al-Cu lamellar
Length	L-295 mm
Connection thread	2xG1/2" inner

Working conditions

Max. temperature	110 °C
Max. overpressure	1 MPa (10 bar)
Protection	IP 20

Ambient conditions	Temp. T = +2 to +40 °C Humidity Rh = 20 to 70%
--------------------	---

Variants

Transverse roll-up grilles

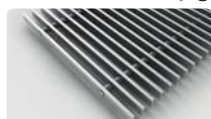

natur - anod. aluminium



bronze - anod. aluminium



black - anod. aluminium

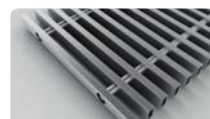

stainless



natur beech - wooden



stained beech - wooden



natur oak - wooden



stained oak - wooden

Linear non-rolling grilles

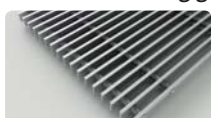

natur - anod. aluminium



bronze - anod. aluminium



black - anod. aluminium

Peripheral ledges



(more on page 7)

More possibilities and variants → page 6

Trench heater standard equipment

Trough	Galvanized steel trough with surface finish and black spray layer inside, black cover plates of connection
Heat exchanger	Al-Cu lamellar exchanger with air vent valve, black painted
Grille	Design walkable grille according the customer's choice*
Ledge	Made of anodized aluminium, type and colour according the customer's choice
Fan	Modern tangential fan with 24 V DC EC motor with high efficiency, rotors protection
Assembly elements	Leveling screws for setting up the trough, mounting brackets
Manual	Manual for the progress of work during installation and user manual
Wiring	Electrical wiring diagram of the trench heaters
Mounting board	Cover and the spacer particle board for easy installation
Package	Transport package for protection against damage during transportation and handling

*stainless grilles surcharge

Accessories per order

	Room thermostat		Power supply
	Lockshield valve		Thermostatic valve

Accessories details → page 11

Technical drawing

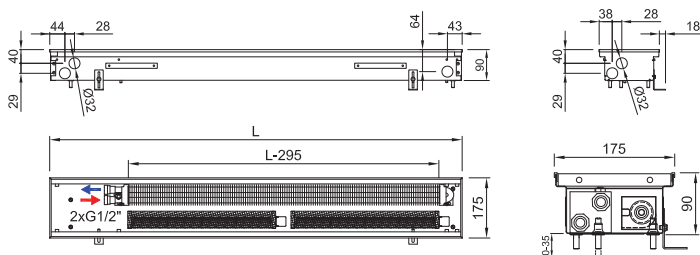

Connection to heating system

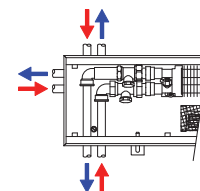

Electrothermal actuator can't be installed in the body of the trench heater due to limited internal space.

The hydraulic parameters of the heat exchanger → page 78

Code example: FRT 0090 0175 1400 C 63 L1 L - 5

Trench heater FRT H=90 mm, W= 175 mm, L=1 400 mm, „C“ Galvanized steel trough with black inside, heat exchanger and inner parts painted black, „63“ natural oak grille, transverse, roll-up „L1“ peripheral ledge „L“ with an overlap, natur anodized aluminium „L“ water connection at the left side (when installing the heat exchanger closer to the window, fans to the room) „5“ 24 V DC fans without controller (controller is not needed)

Q[W] 75/65/20 °C (ΔT=50 °C)

Temperature exponent 1,1

Length L [mm]	Speed [-] / Heating output [W]			
	1	2	3	4 max.
700	102 W	251 W	324 W	390 W
800	136 W	334 W	432 W	520 W
900	163 W	401 W	519 W	624 W
1000	231 W	568 W	735 W	884 W
1100	231 W	568 W	735 W	884 W
1200	272 W	668 W	865 W	1 040 W
1300	299 W	735 W	951 W	1 144 W
1400	333 W	818 W	1 060 W	1 274 W
1500	367 W	902 W	1 168 W	1 403 W
1600	402 W	987 W	1 278 W	1 536 W
1700	402 W	987 W	1 278 W	1 536 W
1800	463 W	1 136 W	1 470 W	1 767 W
1900	504 W	1 238 W	1 602 W	1 926 W
2000	538 W	1 321 W	1 710 W	2 056 W
2100	565 W	1 388 W	1 797 W	2 160 W
2200	565 W	1 388 W	1 797 W	2 160 W
2300	633 W	1 555 W	2 013 W	2 420 W
2400	633 W	1 555 W	2 013 W	2 420 W
2500	674 W	1 655 W	2 143 W	2 576 W
2600	701 W	1 722 W	2 229 W	2 680 W
2700	728 W	1 789 W	2 316 W	2 784 W
2800	769 W	1 889 W	2 446 W	2 939 W
2900	804 W	1 974 W	2 556 W	3 072 W
3000	804 W	1 974 W	2 556 W	3 072 W
3200	906 W	2 225 W	2 880 W	3 462 W
3400	940 W	2 308 W	2 988 W	3 592 W
3600	1 035 W	2 542 W	3 291 W	3 956 W
3800	1 069 W	2 625 W	3 399 W	4 086 W
4000	1 130 W	2 776 W	3 594 W	4 320 W
4200	1 206 W	2 961 W	3 834 W	4 608 W
4400	1 267 W	3 110 W	4 026 W	4 839 W
4600	1 342 W	3 295 W	4 266 W	5 128 W
4800	1 369 W	3 362 W	4 353 W	5 232 W

75/65/20 °C → 75 °C inlet temperature, 65 °C outlet temp., 20 °C room temp. / Output 90/70/20 °C ≈ 1,22 x 75/65/20 °C / Output 70/55/20 °C ≈ 0,84 x 75/65/20 °C / Heating outputs in accordance with EN442 / Not listed heating outputs for lengths per 100 mm steps calculate linearly.

Length L [mm]	Speed [-] / Acoustic pressure [dB(A)]																																
	1	2	3	4 max.																													
700	< 20 dB(A)	20 dB(A)	25 dB(A)	29 dB(A)																													
800		21 dB(A)	26 dB(A)	30 dB(A)																													
900				22 dB(A)	27 dB(A)	31 dB(A)																											
1000		23 dB(A)	28 dB(A)			32 dB(A)																											
1100						24 dB(A)	29 dB(A)	33 dB(A)																									
1200				25 dB(A)	30 dB(A)			34 dB(A)																									
1300								26 dB(A)	31 dB(A)	35 dB(A)																							
1400		27 dB(A)	32 dB(A)							36 dB(A)																							
1500										28 dB(A)	33 dB(A)	37 dB(A)																					
1600						29 dB(A)	34 dB(A)					38 dB(A)																					
1700	30 dB(A)											35 dB(A)	38 dB(A)																				
1800				30 dB(A)	35 dB(A)								38 dB(A)																				
1900													30 dB(A)	35 dB(A)	38 dB(A)																		
2000								30 dB(A)	35 dB(A)						38 dB(A)																		
2100															30 dB(A)	35 dB(A)	38 dB(A)																
2200		30 dB(A)	35 dB(A)														38 dB(A)																
2300																	30 dB(A)	35 dB(A)	38 dB(A)														
2400										30 dB(A)	35 dB(A)								38 dB(A)														
2500																			30 dB(A)	35 dB(A)	38 dB(A)												
2600						30 dB(A)	35 dB(A)														38 dB(A)												
2700																					30 dB(A)	35 dB(A)	38 dB(A)										
2800	30 dB(A)											35 dB(A)											38 dB(A)										
2900																							30 dB(A)	35 dB(A)	38 dB(A)								
3000				30 dB(A)	35 dB(A)																				38 dB(A)								
3200																									30 dB(A)	35 dB(A)	38 dB(A)						
3400													30 dB(A)	35 dB(A)													38 dB(A)						
3600																											30 dB(A)	35 dB(A)	38 dB(A)				
3800								30 dB(A)	35 dB(A)																				38 dB(A)				
4000																													30 dB(A)	35 dB(A)	38 dB(A)		
4200															30 dB(A)	35 dB(A)															38 dB(A)		
4400																															30 dB(A)	35 dB(A)	38 dB(A)
4600		30 dB(A)	35 dB(A)																														38 dB(A)
4800																																	30 dB(A)

Acoustic pressure level choose according to specific environment. More details on page 10

Q[W] 55/45/20 °C (ΔT=30 °C)

Length L [mm]	Speed [-] / Heating output [W]			
	1	2	3	4 max.
700	58 W	143 W	185 W	222 W
800	78 W	190 W	246 W	296 W
900	93 W	229 W	296 W	356 W
1000	132 W	324 W	419 W	504 W
1100	132 W	324 W	419 W	504 W
1200	155 W	381 W	493 W	593 W
1300	170 W	419 W	542 W	652 W
1400	190 W	466 W	604 W	726 W
1500	209 W	514 W	666 W	800 W
1600	229 W	563 W	729 W	876 W
1700	229 W	563 W	729 W	876 W
1800	264 W	648 W	838 W	1 007 W
1900	287 W	706 W	913 W	1 098 W
2000	307 W	753 W	975 W	1 172 W
2100	322 W	791 W	1 025 W	1 231 W
2200	322 W	791 W	1 025 W	1 231 W
2300	361 W	887 W	1 148 W	1 380 W
2400	361 W	887 W	1 148 W	1 380 W
2500	384 W	944 W	1 222 W	1 469 W
2600	400 W	982 W	1 271 W	1 528 W
2700	415 W	1 020 W	1 320 W	1 587 W
2800	438 W	1 077 W	1 395 W	1 676 W
2900	458 W	1 125 W	1 457 W	1 751 W
3000	458 W	1 125 W	1 457 W	1 751 W
3200	517 W	1 269 W	1 642 W	1 974 W
3400	536 W	1 316 W	1 704 W	2 048 W
3600	590 W	1 449 W	1 876 W	2 255 W
3800	609 W	1 497 W	1 938 W	2 330 W
4000	644 W	1 583 W	2 049 W	2 463 W
4200	688 W	1 688 W	2 186 W	2 627 W
4400	722 W	1 773 W	2 295 W	2 759 W
4600	765 W	1 879 W	2 432 W	2 924 W
4800	780 W	1 917 W	2 482 W	2 983 W

Length L [mm]	Speed [-] / Fans input power [W]*			
	1	2	3	4 max.
700	1 W	1 W	2 W	2 W
800	1 W	1 W	2 W	2 W
900	1 W	1 W	2 W	2 W
1000	2 W	2 W	2 W	3 W
1100	2 W	2 W	2 W	3 W
1200	2 W	3 W	3 W	4 W
1300	2 W	3 W	3 W	4 W
1400	3 W	3 W	4 W	5 W
1500	3 W	3 W	4 W	5 W
1600	3 W	3 W	4 W	5 W
1700	3 W	3 W	4 W	5 W
1800	3 W	3 W	4 W	5 W
1900	3 W	4 W	5 W	6 W
2000	4 W	5 W	6 W	7 W
2100	4 W	5 W	6 W	7 W
2200	4 W	5 W	6 W	7 W
2300	4 W	5 W	6 W	7 W
2400	4 W	5 W	6 W	7 W
2500	5 W	6 W	7 W	9 W
2600	5 W	6 W	7 W	9 W
2700	5 W	6 W	7 W	9 W
2800	5 W	6 W	7 W	9 W
2900	5 W	6 W	7 W	9 W
3000	5 W	6 W	7 W	9 W
3200	6 W	8 W	9 W	11 W
3400	6 W	8 W	9 W	11 W
3600	7 W	8 W	10 W	12 W
3800	7 W	9 W	11 W	13 W
4000	7 W	9 W	11 W	13 W
4200	7 W	9 W	11 W	13 W
4400	8 W	10 W	12 W	14 W
4600	8 W	10 W	12 W	15 W
4800	8 W	10 W	12 W	15 W

* Approximate fan input powers / When using electrothermal actuator add in the trench heater's power 3 W / Wiring of the trench heater → page 80

FRT 0090 0200

ECO & SAFE | VOLTAGE 24

TRENCH HEATER WITH FAN



- Flats, detached houses, offices, administrative buildings
- Small universal trench heater
- High heating output
- Continuous speed control
- Quiet operation
- Common electricity consumption **3 W/m**
- Using in dry environment



Technical data

Trench heater

Height	H = 90 mm
Width	W = 200 mm
Length	L = 700-4 800 mm in step 100 mm

Heat exchanger

Type	Al-Cu lamellar
Length	L- 295 mm
Connection thread	2×G1/2" inner

Working conditions

Max. temperature	110 °C
Max. overpressure	1 MPa (10 bar)
Protection	IP 20
Ambient conditions	Temp. T = +2 to +40 °C Humidity Rh = 20 to 70 %

Variants

Transverse roll-up grilles



natur - anod. aluminium



bronze - anod. aluminium

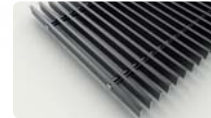

black - anod. aluminium

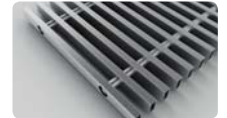

stainless



natur beech - wooden



stained beech - wooden



natur oak - wooden



stained oak - wooden

Linear non-rolling grilles



natur - anod. aluminium



bronze - anod. aluminium



black - anod. aluminium

Peripheral ledges



(more on page 7)

More possibilities and variants → page 6

Trench heater standard equipment

Trough	Galvanized steel trough with surface finish and black spray layer inside, black cover plates of connection
Heat exchanger	Al-Cu lamellar exchanger with air vent valve, black painted
Grille	Design walkable grille according the customer's choice*
Ledge	Made of anodized aluminium, type and colour according the customer's choice
Fan	Modern tangential fan with 24 V DC EC motor with high efficiency, rotors protection
Assembly elements	Leveling screws for setting up the trough, mounting brackets
Manual	Manual for the progress of work during installation and user manual
Wiring	Electrical wiring diagram of the trench heaters
Mounting board	Cover and the spacer particle board for easy installation
Package	Transport package for protection against damage during transportation and handling

*stainless grilles surcharge

Accessories per order

	Room thermostat		Power supply
	Electrothermal actuator		Thermostatic valve
	Lockshield valve		

Accessories details → page 11

Technical drawing

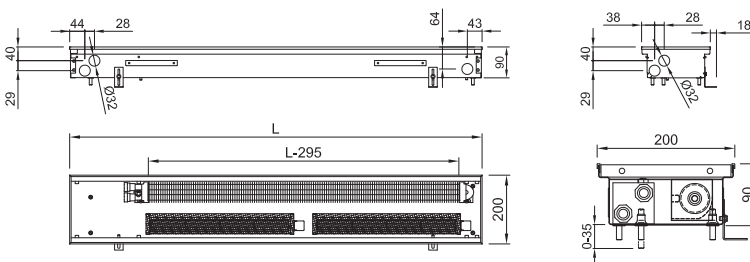

Connection to heating system

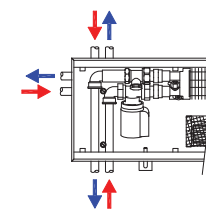

The hydraulic parameters of the heat exchanger → page 78

Code example: FRT 0090 0200 1900 C 52 J1 R - 5

Trench heater FRT H = **90** mm, W = **200** mm, L = **1 900** mm, „C“ Galvanized steel trough with black inside, heat exchanger and inner parts painted black, „52“ stainless grille, transverse, roll-up, „J1“ peripheral ledge „J“, natur anodized aluminium, „R“ water connection at the right side (when installing the heat exchanger closer to the window, fans to the room), „5“ 24 V DC fans without controller (controller is not needed)



Trench heater heating output FRT 0090 0200

Q[W] 75/65/20 °C (ΔT=50 °C)

Temperature exponent 1,1

Length L [mm]	Speed [-] / Heating output [W]			
	1	2	3	4 max.
700	168 W	313 W	432 W	460 W
800	223 W	417 W	576 W	613 W
900	268 W	500 W	691 W	736 W
1000	380 W	708 W	978 W	1 043 W
1100	380 W	708 W	978 W	1 043 W
1200	447 W	833 W	1 151 W	1 227 W
1300	492 W	917 W	1 266 W	1 349 W
1400	548 W	1 021 W	1 410 W	1 503 W
1500	603 W	1 125 W	1 554 W	1 656 W
1600	657 W	1 225 W	1 692 W	1 803 W
1700	657 W	1 225 W	1 692 W	1 803 W
1800	760 W	1 417 W	1 957 W	2 085 W
1900	825 W	1 538 W	2 124 W	2 263 W
2000	880 W	1 642 W	2 268 W	2 416 W
2100	925 W	1 725 W	2 383 W	2 539 W
2200	925 W	1 725 W	2 383 W	2 539 W
2300	1 037 W	1 933 W	2 670 W	2 846 W
2400	1 037 W	1 933 W	2 670 W	2 846 W
2500	1 104 W	2 058 W	2 843 W	3 030 W
2600	1 149 W	2 142 W	2 958 W	3 152 W
2700	1 193 W	2 225 W	3 073 W	3 275 W
2800	1 260 W	2 350 W	3 246 W	3 459 W
2900	1 314 W	2 450 W	3 384 W	3 606 W
3000	1 314 W	2 450 W	3 384 W	3 606 W
3200	1 482 W	2 763 W	3 816 W	4 066 W
3400	1 537 W	2 867 W	3 960 W	4 219 W
3600	1 694 W	3 158 W	4 362 W	4 649 W
3800	1 750 W	3 263 W	4 506 W	4 802 W
4000	1 850 W	3 450 W	4 765 W	5 078 W
4200	1 971 W	3 675 W	5 076 W	5 409 W
4400	2 074 W	3 867 W	5 341 W	5 691 W
4600	2 194 W	4 092 W	5 652 W	6 022 W
4800	2 239 W	4 175 W	5 767 W	6 145 W

Q[W] 55/45/20 °C (ΔT=30 °C)

Length L [mm]	Speed [-] / Heating output [W]			
	1	2	3	4 max.
700	96 W	178 W	246 W	262 W
800	127 W	238 W	328 W	349 W
900	153 W	285 W	394 W	420 W
1000	217 W	404 W	558 W	595 W
1100	217 W	404 W	558 W	595 W
1200	255 W	475 W	656 W	700 W
1300	280 W	523 W	722 W	769 W
1400	312 W	582 W	804 W	857 W
1500	344 W	641 W	886 W	944 W
1600	375 W	698 W	965 W	1 028 W
1700	375 W	698 W	965 W	1 028 W
1800	433 W	808 W	1 116 W	1 189 W
1900	470 W	877 W	1 211 W	1 290 W
2000	502 W	936 W	1 293 W	1 377 W
2100	527 W	983 W	1 359 W	1 448 W
2200	527 W	983 W	1 359 W	1 448 W
2300	591 W	1 102 W	1 522 W	1 623 W
2400	591 W	1 102 W	1 522 W	1 623 W
2500	629 W	1 173 W	1 621 W	1 727 W
2600	655 W	1 221 W	1 686 W	1 797 W
2700	680 W	1 269 W	1 752 W	1 867 W
2800	718 W	1 340 W	1 851 W	1 972 W
2900	749 W	1 397 W	1 929 W	2 056 W
3000	749 W	1 397 W	1 929 W	2 056 W
3200	845 W	1 575 W	2 176 W	2 318 W
3400	876 W	1 635 W	2 258 W	2 405 W
3600	966 W	1 800 W	2 487 W	2 650 W
3800	998 W	1 860 W	2 569 W	2 738 W
4000	1 055 W	1 967 W	2 717 W	2 895 W
4200	1 124 W	2 095 W	2 894 W	3 084 W
4400	1 182 W	2 205 W	3 045 W	3 245 W
4600	1 251 W	2 333 W	3 222 W	3 433 W
4800	1 276 W	2 380 W	3 288 W	3 503 W

75/65/20 °C → 75 °C inlet temperature, 65 °C outlet temp., 20 °C room temp. / **Output 90/70/20 °C** = ~ 1,22 x 75/65/20 °C / **Output 70/55/20 °C** = ~ 0,84 x 75/65/20 °C / Heating outputs in accordance with EN442 / Not listed heating output for lengths per 100 mm steps calculate linearly.



Acoustic pressure [dB(A)]

Length L [mm]	Speed [-] / Acoustic pressure [dB(A)]				
	1	2	3	4 max.	
700		26 dB(A)	34 dB(A)	37 dB(A)	
800			35 dB(A)	38 dB(A)	
900		27 dB(A)			
1000			36 dB(A)	39 dB(A)	
1100					
1200	< 20 dB(A)	28 dB(A)	37 dB(A)	40 dB(A)	
1300					
1400					
1500					
1600					
1700			29 dB(A)	38 dB(A)	41 dB(A)
1800					
1900					
2000	20 dB(A)		39 dB(A)	42 dB(A)	
2100					
2200			30 dB(A)		
2300					
2400	21 dB(A)		40 dB(A)	43 dB(A)	
2500					
2600		31 dB(A)			
2700					
2800	22 dB(A)		41 dB(A)	44 dB(A)	
2900					
3000			32 dB(A)		
3200	23 dB(A)				
3400			33 dB(A)	42 dB(A)	
3600				45 dB(A)	
3800	24 dB(A)		34 dB(A)		
4000					
4200		35 dB(A)	43 dB(A)	46 dB(A)	
4400	25 dB(A)				
4600			36 dB(A)	44 dB(A)	47 dB(A)
4800					

Acoustic pressure level choose according to specific environment. More details on page 10



Fans input power [W]*

Length L [mm]	Speed [-] / Fans input power [W]*			
	1	2	3	4 max.
700	1 W	2 W	2 W	3 W
800	2 W	2 W	3 W	4 W
900	2 W	3 W	4 W	5 W
1000	2 W	3 W	5 W	6 W
1100	2 W	3 W	5 W	6 W
1200	3 W	4 W	6 W	8 W
1300	3 W	5 W	7 W	9 W
1400	3 W	5 W	7 W	9 W
1500	4 W	6 W	8 W	10 W
1600	4 W	6 W	8 W	10 W
1700	4 W	6 W	9 W	11 W
1800	5 W	7 W	10 W	12 W
1900	5 W	7 W	10 W	12 W
2000	5 W	7 W	10 W	13 W
2100	5 W	8 W	11 W	14 W
2200	5 W	8 W	11 W	14 W
2300	6 W	9 W	13 W	16 W
2400	6 W	9 W	13 W	16 W
2500	6 W	9 W	14 W	17 W
2600	7 W	10 W	14 W	18 W
2700	7 W	11 W	15 W	19 W
2800	7 W	11 W	15 W	19 W
2900	7 W	11 W	15 W	19 W
3000	8 W	11 W	16 W	20 W
3200	8 W	12 W	18 W	22 W
3400	9 W	13 W	18 W	23 W
3600	9 W	14 W	20 W	25 W
3800	10 W	14 W	21 W	26 W
4000	11 W	16 W	23 W	28 W
4200	11 W	16 W	23 W	28 W
4400	12 W	17 W	25 W	31 W
4600	12 W	18 W	26 W	32 W
4800	12 W	18 W	27 W	33 W

* Approximate fan input powers / **When using electrothermal actuator add in the trench heater's power 3 W** / Wiring of the trench heater → page 80

FRT 0090 0250

ECO & SAFE | VOLTAGE 24

TRENCH HEATER WITH FAN



- Flats, detached houses, offices, administrative buildings
- Small universal trench heater
- High heating output
- Continuous speed control
- Quiet operation
- Common electricity consumption **3 W/m**
- Using in dry environment



Technical data

Trench heater

Height	H = 90 mm
Width	W = 250 mm
Length	L = 700-4 800 mm in step 100 mm

Heat exchanger

Type	Al-Cu lamellar
Length	L- 295 mm
Connection thread	2xG1/2" inner

Working conditions

Max. temperature	110 °C
Max. overpressure	1 MPa (10 bar)
Protection	IP 20
Ambient conditions	Temp. T = +2 to +40 °C Humidity Rh = 20 to 70 %

Variants

Transverse roll-up grilles

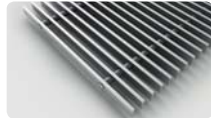

natur - anod. aluminium



bronze - anod. aluminium

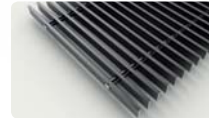

black - anod. aluminium

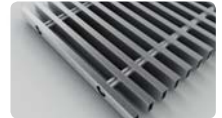

stainless



natur beech - wooden



stained beech - wooden



natur oak - wooden



stained oak - wooden

Linear non-rolling grilles



natur - anod. aluminium



bronze - anod. aluminium



black - anod. aluminium

Peripheral ledges



(more on page 7)

More possibilities and variants → page 6

Trench heater standard equipment

Trough	Galvanized steel trough with surface finish and black spray layer inside, black cover plates of connection
Heat exchanger	Al-Cu lamellar exchanger with air vent valve, black painted
Grille	Design walkable grille according the customer's choice*
Ledge	Made of anodized aluminium, type and colour according the customer's choice
Fan	Modern tangential fan with 24 V DC EC motor with high efficiency, rotors protection
Assembly elements	Leveling screws for setting up the trough, mounting brackets
Manual	Manual for the progress of work during installation and user manual
Wiring	Electrical wiring diagram of the trench heaters
Mounting board	Cover and the spacer particle board for easy installation
Package	Transport package for protection against damage during transportation and handling

*stainless grilles surcharge

Accessories per order

	Room thermostat		Power supply
	Electrothermal actuator		Thermostatic valve
	Lockshield valve		

Accessories details → page 11

Technical drawing

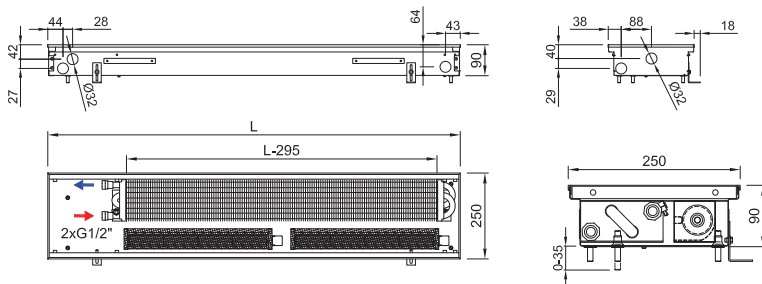

Connection to heating system

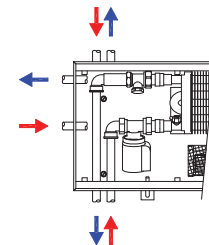

The hydraulic parameters of the heat exchanger → page 78

Code example: FRT 0090 0250 1500 C 62 L2 L - 5

Trench heater FRT H=90 mm, W= 250 mm, L= 1 500 mm, „C“ Galvanized steel trough with black inside, heat exchanger and inner parts painted black, „62“ stained beech grille, transverse, roll-up „L2“ peripheral ledge „L“ with an overlap, bronze anodized aluminium, „L“ water connection at the left side (when installing the heat exchanger closer to the window, fans to the room) „5“ 24 V DC fans without controller (controller is not needed)

 **Trench heater heating output FRT 0090 0250**

Q[W] 75/65/20 °C (ΔT=50 °C)

Temperature exponent 1,1

Length L [mm]	Speed [-] / Heating output [W]			
	1	2	3	4 max.
700	253 W	535 W	705 W	752 W
800	337 W	714 W	939 W	1 003 W
900	404 W	856 W	1 127 W	1 204 W
1000	573 W	1 213 W	1 597 W	1 705 W
1100	573 W	1 213 W	1 597 W	1 705 W
1200	674 W	1 427 W	1 879 W	2 006 W
1300	742 W	1 570 W	2 067 W	2 206 W
1400	826 W	1 748 W	2 302 W	2 457 W
1500	910 W	1 927 W	2 536 W	2 708 W
1600	991 W	2 098 W	2 762 W	2 949 W
1700	991 W	2 098 W	2 762 W	2 949 W
1800	1 146 W	2 426 W	3 194 W	3 410 W
1900	1 244 W	2 633 W	3 466 W	3 701 W
2000	1 328 W	2 811 W	3 701 W	3 952 W
2100	1 395 W	2 954 W	3 889 W	4 152 W
2200	1 395 W	2 954 W	3 889 W	4 152 W
2300	1 564 W	3 311 W	4 359 W	4 654 W
2400	1 564 W	3 311 W	4 359 W	4 654 W
2500	1 665 W	3 525 W	4 641 W	4 955 W
2600	1 732 W	3 668 W	4 829 W	5 155 W
2700	1 800 W	3 810 W	5 016 W	5 356 W
2800	1 901 W	4 024 W	5 298 W	5 657 W
2900	1 982 W	4 196 W	5 524 W	5 897 W
3000	1 982 W	4 196 W	5 524 W	5 897 W
3200	2 235 W	4 731 W	6 228 W	6 650 W
3400	2 319 W	4 909 W	6 463 W	6 900 W
3600	2 555 W	5 409 W	7 121 W	7 602 W
3800	2 639 W	5 587 W	7 356 W	7 853 W
4000	2 791 W	5 908 W	7 778 W	8 304 W
4200	2 973 W	6 293 W	8 286 W	8 846 W
4400	3 128 W	6 622 W	8 718 W	9 307 W
4600	3 310 W	7 007 W	9 225 W	9 849 W
4800	3 377 W	7 150 W	9 413 W	10 049 W

Q[W] 55/45/20 °C (ΔT=30 °C)

Length L [mm]	Speed [-] / Heating output [W]			
	1	2	3	4 max.
700	144 W	305 W	402 W	429 W
800	192 W	407 W	535 W	572 W
900	230 W	488 W	643 W	686 W
1000	327 W	692 W	910 W	972 W
1100	327 W	692 W	910 W	972 W
1200	384 W	814 W	1 071 W	1 144 W
1300	423 W	895 W	1 178 W	1 258 W
1400	471 W	997 W	1 312 W	1 401 W
1500	519 W	1 099 W	1 446 W	1 544 W
1600	565 W	1 196 W	1 575 W	1 681 W
1700	565 W	1 196 W	1 575 W	1 681 W
1800	653 W	1 383 W	1 821 W	1 944 W
1900	709 W	1 501 W	1 976 W	2 110 W
2000	757 W	1 603 W	2 110 W	2 253 W
2100	795 W	1 684 W	2 217 W	2 367 W
2200	795 W	1 684 W	2 217 W	2 367 W
2300	892 W	1 888 W	2 485 W	2 653 W
2400	892 W	1 888 W	2 485 W	2 653 W
2500	949 W	2 010 W	2 646 W	2 825 W
2600	987 W	2 091 W	2 753 W	2 939 W
2700	1 026 W	2 172 W	2 860 W	3 054 W
2800	1 084 W	2 294 W	3 020 W	3 225 W
2900	1 130 W	2 392 W	3 149 W	3 362 W
3000	1 130 W	2 392 W	3 149 W	3 362 W
3200	1 274 W	2 697 W	3 551 W	3 791 W
3400	1 322 W	2 799 W	3 685 W	3 934 W
3600	1 457 W	3 084 W	4 060 W	4 334 W
3800	1 505 W	3 185 W	4 194 W	4 477 W
4000	1 591 W	3 368 W	4 434 W	4 734 W
4200	1 695 W	3 588 W	4 724 W	5 043 W
4400	1 783 W	3 775 W	4 970 W	5 306 W
4600	1 887 W	3 995 W	5 259 W	5 615 W
4800	1 925 W	4 076 W	5 367 W	5 729 W

75/65/20 °C → 75 °C inlet temperature, 65 °C outlet temp., 20 °C room temp. / **Output 90/70/20 °C** = ~ 1,22 x 75/65/20 °C / **Output 70/55/20 °C** = ~ 0,84 x 75/65/20 °C / Heating outputs in accordance with EN442 / Not listed heating outputs for lengths per 100 mm steps calculate linearly.

 **Acoustic pressure [dB(A)]**

Length L [mm]	Speed [-] / Acoustic pressure [dB(A)]			
	1	2	3	4 max.
700		26 dB(A)	34 dB(A)	37 dB(A)
800			35 dB(A)	38 dB(A)
900		27 dB(A)		
1000			36 dB(A)	39 dB(A)
1100				
1200	< 20 dB(A)	28 dB(A)	37 dB(A)	40 dB(A)
1300				
1400				
1500				
1600				
1700		29 dB(A)	38 dB(A)	41 dB(A)
1800				
1900				
2000	20 dB(A)		39 dB(A)	42 dB(A)
2100				
2200		30 dB(A)		
2300				
2400	21 dB(A)		40 dB(A)	43 dB(A)
2500				
2600		31 dB(A)		
2700				
2800	22 dB(A)		41 dB(A)	44 dB(A)
2900				
3000		32 dB(A)		
3200	23 dB(A)			
3400			33 dB(A)	42 dB(A)
3600				45 dB(A)
3800	24 dB(A)		34 dB(A)	
4000				
4200		35 dB(A)	43 dB(A)	46 dB(A)
4400	25 dB(A)			
4600			36 dB(A)	44 dB(A)
4800	26 dB(A)			

Acoustic pressure level choose according to specific environment. More details on page 10

 **Fans input power [W]***

Length L [mm]	Speed [-] / Fans input power [W]*			
	1	2	3	4 max.
700	1 W	2 W	2 W	3 W
800	2 W	2 W	3 W	4 W
900	2 W	3 W	4 W	5 W
1000	2 W	3 W	5 W	6 W
1100	2 W	3 W	5 W	6 W
1200	3 W	4 W	6 W	8 W
1300	3 W	5 W	7 W	9 W
1400	3 W	5 W	7 W	9 W
1500	4 W	6 W	8 W	10 W
1600	4 W	6 W	8 W	10 W
1700	4 W	6 W	9 W	11 W
1800	5 W	7 W	10 W	12 W
1900	5 W	7 W	10 W	12 W
2000	5 W	7 W	10 W	13 W
2100	5 W	8 W	11 W	14 W
2200	5 W	8 W	11 W	14 W
2300	6 W	9 W	13 W	16 W
2400	6 W	9 W	13 W	16 W
2500	6 W	9 W	14 W	17 W
2600	7 W	10 W	14 W	18 W
2700	7 W	11 W	15 W	19 W
2800	7 W	11 W	15 W	19 W
2900	7 W	11 W	15 W	19 W
3000	8 W	11 W	16 W	20 W
3200	8 W	12 W	18 W	22 W
3400	9 W	13 W	18 W	23 W
3600	9 W	14 W	20 W	25 W
3800	10 W	14 W	21 W	26 W
4000	11 W	16 W	23 W	28 W
4200	11 W	16 W	23 W	28 W
4400	12 W	17 W	25 W	31 W
4600	12 W	18 W	26 W	32 W
4800	12 W	18 W	27 W	33 W

* Approximate fan input powers / **When using electrothermal actuator add in the trench heater's power 3 W** / Wiring of the trench heater → page 80

FRT 0090 0300

ECO & SAFE | VOLTAGE 24

TRENCH HEATER WITH FAN



- Flats, detached houses, offices, administrative buildings
- Low trench heater with a good heating output
- High heating output
- Continuous speed control
- Quiet operation
- Common electricity consumption **3 W/m**
- Using in dry environment



Technical data

Trench heater

Height	H = 90 mm
Width	W = 300 mm
Length	L = 700-4 800 mm in step 100 mm

Heat exchanger

Type	Al-Cu lamellar
Length	L- 295 mm
Connection thread	2xG1/2" inner

Working conditions

Max. temperature	110 °C
Max. overpressure	1 MPa (10 bar)
Protection	IP 20
Ambient conditions	Temp. T = +2 to +40 °C Humidity Rh = 20 to 70 %

Variants

Transverse roll-up grilles

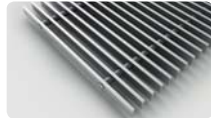

natur - anod. aluminium



bronze - anod. aluminium

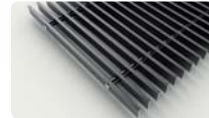

black - anod. aluminium

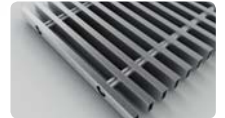

stainless



natur beech - wooden



stained beech - wooden



natur oak - wooden



stained oak - wooden

Linear non-rolling grilles



natur - anod. aluminium



bronze - anod. aluminium



black - anod. aluminium

Peripheral ledges



(more on page 7)

More possibilities and variants → page 6

Trench heater standard equipment

Trough	Galvanized steel trough with surface finish and black spray layer inside, black cover plates of connection
Heat exchanger	Al-Cu lamellar exchanger with air vent valve, black painted
Grille	Design walkable grille according the customer's choice*
Ledge	Made of anodized aluminium, type and colour according the customer's choice
Fan	Modern tangential fan with 24 V DC EC motor with high efficiency, rotors protection
Assembly elements	Leveling screws for setting up the trough, mounting brackets
Manual	Manual for the progress of work during installation and user manual
Wiring	Electrical wiring diagram of the trench heaters
Mounting board	Cover and the spacer particle board for easy installation
Package	Transport package for protection against damage during transportation and handling

*stainless grilles surcharge

Accessories per order

	Room thermostat		Power supply
	Electrothermal actuator		Thermostatic valve
	Lockshield valve		

Accessories details → page 11

Technical drawing

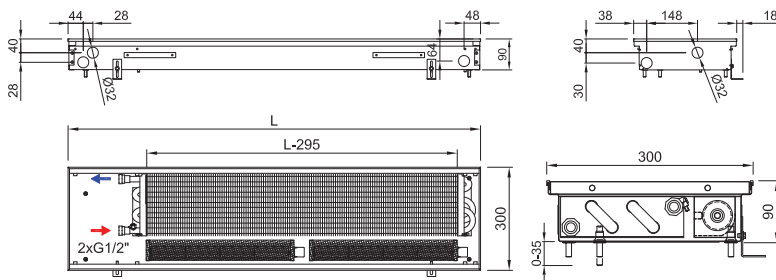

Connection to heating system

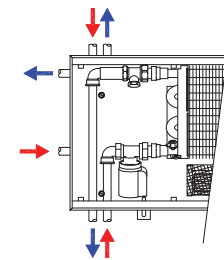

The hydraulic parameters of the heat exchanger → page 78

Code example: FRT 0090 0300 2700 C 32 J3 R - 5

Trench heater FRT H=90 mm, W= 300 mm, L=2 700 mm, „C“ Galvanized steel trough with black inside, heat exchanger and inner parts painted black, „32“ black anodized aluminium grille, linear, rigid, „J3“ peripheral ledge „J“, black anodized aluminium „R“ water connection at the right side (when installing the heat exchanger closer to the window, fans to the room), „5“ 24 V DC fans without controller (controller is not needed)

 **Trench heater heating output FRT 0090 0300**

Q[W] 75/65/20 °C (ΔT=50 °C)

Temperature exponent 1,1

Length L [mm]	Speed [-] / Heating output [W]			
	1	2	3	4 max.
700	270 W	572 W	749 W	803 W
800	361 W	762 W	999 W	1 071 W
900	433 W	915 W	1 199 W	1 285 W
1000	613 W	1 296 W	1 698 W	1 820 W
1100	613 W	1 296 W	1 698 W	1 820 W
1200	721 W	1 525 W	1 998 W	2 141 W
1300	793 W	1 677 W	2 197 W	2 355 W
1400	883 W	1 868 W	2 447 W	2 623 W
1500	974 W	2 058 W	2 697 W	2 891 W
1600	1 060 W	2 241 W	2 937 W	3 148 W
1700	1 060 W	2 241 W	2 937 W	3 148 W
1800	1 226 W	2 592 W	3 396 W	3 640 W
1900	1 331 W	2 813 W	3 686 W	3 950 W
2000	1 421 W	3 004 W	3 935 W	4 218 W
2100	1 493 W	3 156 W	4 135 W	4 432 W
2200	1 493 W	3 156 W	4 135 W	4 432 W
2300	1 673 W	3 537 W	4 635 W	4 968 W
2400	1 673 W	3 537 W	4 635 W	4 968 W
2500	1 781 W	3 766 W	4 934 W	5 289 W
2600	1 853 W	3 918 W	5 134 W	5 503 W
2700	1 926 W	4 071 W	5 334 W	5 717 W
2800	2 034 W	4 300 W	5 633 W	6 038 W
2900	2 120 W	4 483 W	5 873 W	6 295 W
3000	2 120 W	4 483 W	5 873 W	6 295 W
3200	2 391 W	5 054 W	6 622 W	7 098 W
3400	2 481 W	5 245 W	6 872 W	7 366 W
3600	2 733 W	5 779 W	7 571 W	8 115 W
3800	2 823 W	5 969 W	7 821 W	8 383 W
4000	2 986 W	6 312 W	8 270 W	8 864 W
4200	3 180 W	6 724 W	8 810 W	9 443 W
4400	3 346 W	7 075 W	9 269 W	9 935 W
4600	3 541 W	7 486 W	9 808 W	10 513 W
4800	3 613 W	7 639 W	10 008 W	10 727 W

Q[W] 55/45/20 °C (ΔT=30 °C)

Length L [mm]	Speed [-] / Heating output [W]			
	1	2	3	4 max.
700	154 W	326 W	427 W	458 W
800	206 W	434 W	570 W	611 W
900	247 W	522 W	684 W	733 W
1000	349 W	739 W	968 W	1 038 W
1100	349 W	739 W	968 W	1 038 W
1200	411 W	869 W	1 139 W	1 221 W
1300	452 W	956 W	1 253 W	1 343 W
1400	503 W	1 065 W	1 395 W	1 495 W
1500	555 W	1 173 W	1 538 W	1 648 W
1600	604 W	1 278 W	1 674 W	1 795 W
1700	604 W	1 278 W	1 674 W	1 795 W
1800	699 W	1 478 W	1 936 W	2 075 W
1900	759 W	1 604 W	2 101 W	2 252 W
2000	810 W	1 713 W	2 243 W	2 405 W
2100	851 W	1 799 W	2 357 W	2 527 W
2200	851 W	1 799 W	2 357 W	2 527 W
2300	954 W	2 017 W	2 643 W	2 832 W
2400	954 W	2 017 W	2 643 W	2 832 W
2500	1 015 W	2 147 W	2 813 W	3 015 W
2600	1 056 W	2 234 W	2 927 W	3 137 W
2700	1 098 W	2 321 W	3 041 W	3 259 W
2800	1 160 W	2 452 W	3 211 W	3 442 W
2900	1 209 W	2 556 W	3 348 W	3 589 W
3000	1 209 W	2 556 W	3 348 W	3 589 W
3200	1 363 W	2 881 W	3 775 W	4 047 W
3400	1 414 W	2 990 W	3 918 W	4 200 W
3600	1 558 W	3 295 W	4 316 W	4 627 W
3800	1 609 W	3 403 W	4 459 W	4 779 W
4000	1 702 W	3 599 W	4 715 W	5 054 W
4200	1 813 W	3 833 W	5 023 W	5 384 W
4400	1 908 W	4 034 W	5 284 W	5 664 W
4600	2 019 W	4 265 W	5 592 W	5 994 W
4800	2 060 W	4 358 W	5 706 W	6 116 W

75/65/20 °C → 75 °C inlet temperature, 65 °C outlet temp., 20 °C room temp. / **Output 90/70/20 °C** = ~ 1,22 x 75/65/20 °C / **Output 70/55/20 °C** = ~ 0,84 x 75/65/20 °C / Heating outputs in accordance with EN442 / Not listed heating outputs for lengths per 100 mm steps calculate linearly.

 **Acoustic pressure [dB(A)]**

Length L [mm]	Speed [-] / Acoustic pressure [dB(A)]					
	1	2	3	4 max.		
700	< 20 dB(A)	26 dB(A)	34 dB(A)	37 dB(A)		
800		27 dB(A)	35 dB(A)	38 dB(A)		
900						
1000		28 dB(A)	36 dB(A)	39 dB(A)		
1100						
1200						
1300		29 dB(A)	37 dB(A)	40 dB(A)		
1400						
1500						
1600						
1700	20 dB(A)	38 dB(A)	41 dB(A)			
1800						
1900						
2000						
2100						
2200	21 dB(A)	39 dB(A)	42 dB(A)			
2300						
2400						
2500						
2600						
2700						
2800	22 dB(A)	40 dB(A)	43 dB(A)			
2900						
3000						
3200						
3400						
3600						
3800						
4000	23 dB(A)	31 dB(A)	44 dB(A)			
4200						
4400						
4600						
4800						
4800				24 dB(A)	32 dB(A)	45 dB(A)
4800						
4800						
4800						
4800						
4800						
4800						
4800						
4800						
4800	25 dB(A)	33 dB(A)	46 dB(A)			
4800						
4800						
4800						
4800						
4800						
4800						
4800						
4800						
4800						
4800	26 dB(A)	34 dB(A)	47 dB(A)			
4800						
4800						
4800						
4800						
4800						
4800						
4800						
4800						
4800						
4800						

Acoustic pressure level choose according to specific environment. More details on page 10

 **Fans input power [W]***

Length L [mm]	Speed [-] / Fans input power [W]*			
	1	2	3	4 max.
700	1 W	2 W	2 W	3 W
800	2 W	2 W	3 W	4 W
900	2 W	3 W	4 W	5 W
1000	2 W	3 W	5 W	6 W
1100	2 W	3 W	5 W	6 W
1200	3 W	4 W	6 W	8 W
1300	3 W	5 W	7 W	9 W
1400	3 W	5 W	7 W	9 W
1500	4 W	6 W	8 W	10 W
1600	4 W	6 W	8 W	10 W
1700	4 W	6 W	9 W	11 W
1800	5 W	7 W	10 W	12 W
1900	5 W	7 W	10 W	12 W
2000	5 W	7 W	10 W	13 W
2100	5 W	8 W	11 W	14 W
2200	5 W	8 W	11 W	14 W
2300	6 W	9 W	13 W	16 W
2400	6 W	9 W	13 W	16 W
2500	6 W	9 W	14 W	17 W
2600	7 W	10 W	14 W	18 W
2700	7 W	11 W	15 W	19 W
2800	7 W	11 W	15 W	19 W
2900	7 W	11 W	15 W	19 W
3000	8 W	11 W	16 W	20 W
3200	8 W	12 W	18 W	22 W
3400	9 W	13 W	18 W	23 W
3600	9 W	14 W	20 W	25 W
3800	10 W	14 W	21 W	26 W
4000	11 W	16 W	23 W	28 W
4200	11 W	16 W	23 W	28 W
4400	12 W	17 W	25 W	31 W
4600	12 W	18 W	26 W	32 W
4800	12 W	18 W	27 W	33 W

* Approximate fan input powers / **When using electrothermal actuator add in the trench heater's power 3 W** / Wiring of the trench heater → page 80

FRT 0090 0425

TRENCH HEATER WITH FAN

ECO & SAFE | VOLTAGE 24



- Flats, detached houses, offices, administrative buildings
- High heating output
- Continuous speed control
- Quiet operation
- Common electricity consumption **3 W/m**
- Using in dry environment



Technical data

Trench heater

Height	H = 90 mm
Width	W = 425 mm
Length	L = 700-4 800 mm in step 100 mm

Heat exchanger

Type	Al-Cu lamellar
Length	L- 295 mm
Connection thread	2xG1/2" inner

Working conditions

Max. temperature	110 °C
Max. overpressure	1 MPa (10 bar)
Protection	IP 20

Ambient conditions	Temp. T = +2 to +40 °C Humidity Rh = 20 to 70 %
--------------------	--

Variants

Transverse roll-up grilles



natur - anod. aluminium



bronze - anod. aluminium



black - anod. aluminium

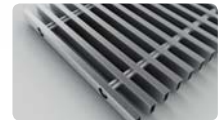

stainless

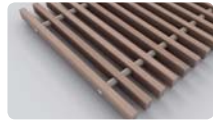

natur beech - wooden



stained beech - wooden



natur oak - wooden



stained oak - wooden

Linear non-rolling grilles



natur - anod. aluminium



bronze - anod. aluminium



black - anod. aluminium

Peripheral ledges



(more on page 7)

More possibilities and variants → page 6

Trench heater standard equipment

Trough	Galvanized steel trough with surface finish and black spray layer inside, black cover plates of connection
Heat exchanger	Al-Cu lamellar exchanger with air vent valve, black painted
Grille	Design walkable grille according the customer's choice*
Ledge	Made of anodized aluminium, type and colour according the customer's choice
Fan	Modern tangential fan with 24 V DC EC motor with high efficiency, rotors protection
Assembly elements	Leveling screws for setting up the trough, mounting brackets
Manual	Manual for the progress of work during installation and user manual
Wiring	Electrical wiring diagram of the trench heaters
Mounting board	Cover and the spacer particle board for easy installation
Package	Transport package for protection against damage during transportation and handling

*stainless grilles surcharge

Accessories per order

	Room thermostat		Power supply
	Electrothermal actuator		Thermostatic valve
	Lockshield valve		

Accessories details → page 11

Technical drawing

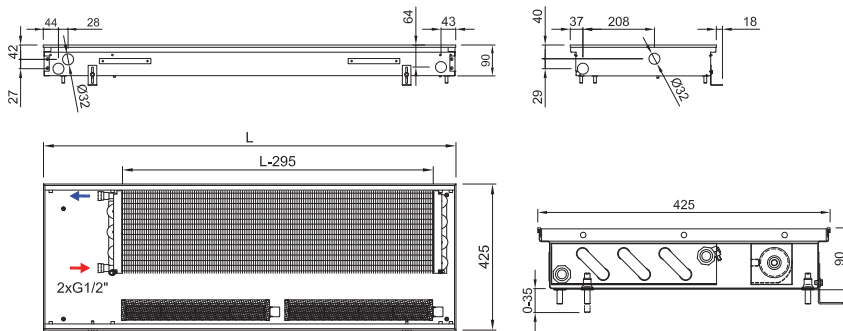

Connection to heating system

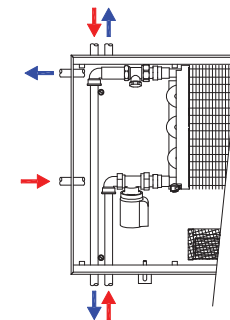

The hydraulic parameters of the heat exchanger → page 78

Code example: FRT 0090 0425 4400 C 64 L2 L - 5

Trench heater FRT H = 90 mm, W = 425 mm, L = 4 400 mm, „C“ Galvanized steel trough with black inside, heat exchanger and inner parts painted black, „64“ stained oak grille, transverse, roll-up, „L2“ peripheral ledge, „L“ with an overlap, bronze anodized aluminium, „L“ water connection at the left side (when installing the heat exchanger closer to the window, fans to the room), „5“ 24 V DC fans without controller (controller is not needed)

 **Trench heater heating output FRT 0090 0425**

Q[W] 75/65/20 °C (ΔT=50 °C)

Temperature exponent 1,1

Length L [mm]	Speed [-] / Heating output [W]			
	1	2	3	4 max.
700	289 W	626 W	839 W	871 W
800	386 W	835 W	1 119 W	1 162 W
900	463 W	1 002 W	1 343 W	1 394 W
1000	656 W	1 420 W	1 903 W	1 975 W
1100	656 W	1 420 W	1 903 W	1 975 W
1200	772 W	1 670 W	2 238 W	2 323 W
1300	849 W	1 837 W	2 462 W	2 556 W
1400	945 W	2 046 W	2 742 W	2 846 W
1500	1 042 W	2 255 W	3 022 W	3 137 W
1600	1 134 W	2 455 W	3 290 W	3 415 W
1700	1 134 W	2 455 W	3 290 W	3 415 W
1800	1 312 W	2 839 W	3 805 W	3 950 W
1900	1 424 W	3 081 W	4 130 W	4 287 W
2000	1 520 W	3 290 W	4 410 W	4 577 W
2100	1 597 W	3 457 W	4 633 W	4 809 W
2200	1 597 W	3 457 W	4 633 W	4 809 W
2300	1 790 W	3 874 W	5 193 W	5 390 W
2400	1 790 W	3 874 W	5 193 W	5 390 W
2500	1 906 W	4 125 W	5 529 W	5 739 W
2600	1 983 W	4 292 W	5 753 W	5 971 W
2700	2 060 W	4 459 W	5 976 W	6 203 W
2800	2 176 W	4 709 W	6 312 W	6 552 W
2900	2 269 W	4 910 W	6 581 W	6 831 W
3000	2 269 W	4 910 W	6 581 W	6 831 W
3200	2 558 W	5 536 W	7 420 W	7 702 W
3400	2 655 W	5 745 W	7 700 W	7 992 W
3600	2 925 W	6 329 W	8 483 W	8 805 W
3800	3 021 W	6 538 W	8 763 W	9 096 W
4000	3 195 W	6 914 W	9 267 W	9 619 W
4200	3 403 W	7 365 W	9 871 W	10 246 W
4400	3 581 W	7 749 W	10 386 W	10 780 W
4600	3 789 W	8 200 W	10 990 W	11 408 W
4800	3 866 W	8 367 W	11 214 W	11 640 W

75/65/20 °C → 75 °C inlet temperature, 65 °C outlet temp., 20 °C room temp. / **Output 90/70/20 °C** = ~ 1,22 x 75/65/20 °C / **Output 70/55/20 °C** = ~ 0,84 x 75/65/20 °C / Heating outputs in accordance with EN442 / Not listed heating outputs for lengths per 100 mm steps calculate linearly.

Q[W] 55/45/20 °C (ΔT=30 °C)

Length L [mm]	Speed [-] / Heating output [W]			
	1	2	3	4 max.
700	165 W	357 W	478 W	497 W
800	220 W	476 W	638 W	662 W
900	264 W	571 W	766 W	795 W
1000	374 W	810 W	1 085 W	1 126 W
1100	374 W	810 W	1 085 W	1 126 W
1200	440 W	952 W	1 276 W	1 324 W
1300	484 W	1 047 W	1 404 W	1 457 W
1400	539 W	1 166 W	1 563 W	1 623 W
1500	594 W	1 286 W	1 723 W	1 788 W
1600	647 W	1 400 W	1 876 W	1 947 W
1700	647 W	1 400 W	1 876 W	1 947 W
1800	748 W	1 619 W	2 169 W	2 252 W
1900	812 W	1 757 W	2 355 W	2 444 W
2000	867 W	1 876 W	2 514 W	2 609 W
2100	910 W	1 971 W	2 641 W	2 742 W
2200	910 W	1 971 W	2 641 W	2 742 W
2300	1 021 W	2 209 W	2 961 W	3 073 W
2400	1 021 W	2 209 W	2 961 W	3 073 W
2500	1 087 W	2 352 W	3 152 W	3 272 W
2600	1 131 W	2 447 W	3 280 W	3 404 W
2700	1 174 W	2 542 W	3 407 W	3 536 W
2800	1 241 W	2 685 W	3 599 W	3 735 W
2900	1 294 W	2 799 W	3 752 W	3 894 W
3000	1 294 W	2 799 W	3 752 W	3 894 W
3200	1 458 W	3 156 W	4 230 W	4 391 W
3400	1 514 W	3 275 W	4 390 W	4 556 W
3600	1 668 W	3 608 W	4 836 W	5 020 W
3800	1 722 W	3 727 W	4 996 W	5 186 W
4000	1 822 W	3 942 W	5 283 W	5 484 W
4200	1 940 W	4 199 W	5 628 W	5 841 W
4400	2 042 W	4 418 W	5 921 W	6 146 W
4600	2 160 W	4 675 W	6 266 W	6 504 W
4800	2 204 W	4 770 W	6 393 W	6 636 W

 **Acoustic pressure [dB(A)]**

Length L [mm]	Speed [-] / Acoustic pressure [dB(A)]				
	1	2	3	4 max.	
700		26 dB(A)	34 dB(A)	37 dB(A)	
800			35 dB(A)	38 dB(A)	
900		27 dB(A)			
1000			36 dB(A)	39 dB(A)	
1100					
1200	< 20 dB(A)		37 dB(A)	40 dB(A)	
1300					
1400			28 dB(A)		
1500				38 dB(A)	41 dB(A)
1600					
1700		29 dB(A)			
1800			39 dB(A)	42 dB(A)	
1900					
2000	20 dB(A)				
2100			40 dB(A)	43 dB(A)	
2200		30 dB(A)			
2300					
2400			41 dB(A)	44 dB(A)	
2500	21 dB(A)				
2600		31 dB(A)			
2700			42 dB(A)	45 dB(A)	
2800					
2900	22 dB(A)		43 dB(A)	46 dB(A)	
3000		32 dB(A)			
3200			44 dB(A)	47 dB(A)	
3400	23 dB(A)				
3600		33 dB(A)			
3800	24 dB(A)		45 dB(A)		
4000		34 dB(A)			
4200			46 dB(A)	48 dB(A)	
4400	25 dB(A)				
4600		35 dB(A)			
4800	26 dB(A)		47 dB(A)		

Acoustic pressure level choose according to specific environment. More details on page 10

 **Fans input power [W]***

Length L [mm]	Speed [-] / Fans input power [W]*			
	1	2	3	4 max.
700	1 W	2 W	2 W	3 W
800	2 W	2 W	3 W	4 W
900	2 W	3 W	4 W	5 W
1000	2 W	3 W	5 W	6 W
1100	2 W	3 W	5 W	6 W
1200	3 W	4 W	6 W	8 W
1300	3 W	5 W	7 W	9 W
1400	3 W	5 W	7 W	9 W
1500	4 W	6 W	8 W	10 W
1600	4 W	6 W	8 W	10 W
1700	4 W	6 W	9 W	11 W
1800	5 W	7 W	10 W	12 W
1900	5 W	7 W	10 W	12 W
2000	5 W	7 W	10 W	13 W
2100	5 W	8 W	11 W	14 W
2200	5 W	8 W	11 W	14 W
2300	6 W	9 W	13 W	16 W
2400	6 W	9 W	13 W	16 W
2500	6 W	9 W	14 W	17 W
2600	7 W	10 W	14 W	18 W
2700	7 W	11 W	15 W	19 W
2800	7 W	11 W	15 W	19 W
2900	7 W	11 W	15 W	19 W
3000	8 W	11 W	16 W	20 W
3200	8 W	12 W	18 W	22 W
3400	9 W	13 W	18 W	23 W
3600	9 W	14 W	20 W	25 W
3800	10 W	14 W	21 W	26 W
4000	11 W	16 W	23 W	28 W
4200	11 W	16 W	23 W	28 W
4400	12 W	17 W	25 W	31 W
4600	12 W	18 W	26 W	32 W
4800	12 W	18 W	27 W	33 W

* Approximate fan input powers / **When using electrothermal actuator add in the trench heater's power 3 W** / Wiring of the trench heater → page 80

FRT 0110 0175

ECO & SAFE | VOLTAGE 24

TRENCH HEATER WITH FAN



- Flats, detached houses, offices, administrative buildings
- Narrow trench heater suitable for a standard floor
- High heating output
- Continuous speed control
- Quiet operation
- Common electricity consumption **2 W/m**
- Using in dry environment



Technical data

Trench heater

Height	H = 110 mm
Width	W = 175 mm
Length	L = 700-4 800 mm in step 100 mm

Heat exchanger

Type	Al-Cu lamellar
Length	L- 295 mm
Connection thread	2xG1/2" inner

Working conditions

Max. temperature	110 °C
Max. overpressure	1 MPa (10 bar)
Protection	IP 20

Ambient conditions	Temp. T = +2 to +40 °C Humidity Rh = 20 to 70 %
--------------------	--

Variants

Transverse roll-up grilles



natur - anod. aluminium



bronze - anod. aluminium



black - anod. aluminium

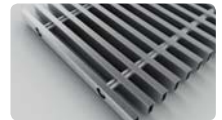

stainless



natur beech - wooden



stained beech - wooden



natur oak - wooden



stained oak - wooden

Linear non-rolling grilles



natur - anod. aluminium



bronze - anod. aluminium



black - anod. aluminium

Peripheral ledges



(more on page 7)

More possibilities and variants → page 6

Trench heater standard equipment

Trough	Galvanized steel trough with surface finish and black spray layer inside, black cover plates of connection
Heat exchanger	Al-Cu lamellar exchanger with air vent valve, black painted
Grille	Design walkable grille according the customer's choice*
Ledge	Made of anodized aluminium, type and colour according the customer's choice
Fan	Modern tangential fan with 24 V DC EC motor with high efficiency, rotors protection
Assembly elements	Leveling screws for setting up the trough, mounting brackets
Manual	Manual for the progress of work during installation and user manual
Wiring	Electrical wiring diagram of the trench heaters
Mounting board	Cover and the spacer particle board for easy installation
Package	Transport package for protection against damage during transportation and handling

*stainless grilles surcharge

Accessories per order

	Room thermostat		Power supply
	Lockshield valve		Thermostatic valve

Accessories details → page 11

Technical drawing

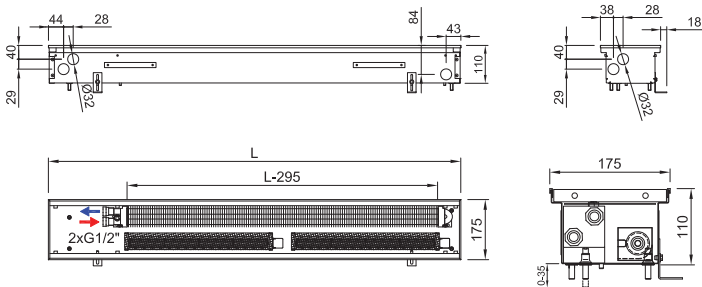

Connection to heating system

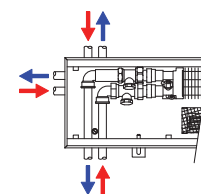

Electrothermal actuator can't be installed in the body of the trench heater due to limited internal space.

The hydraulic parameters of the heat exchanger → page 78

Code example: FRT 0110 0175 1400 C 63 L1 L - 5

Trench heater FRT H=110 mm, W= 175 mm, L=1 400 mm, „C“ Galvanized steel trough with black inside, heat exchanger and inner parts painted black, „63“ natural oak grille, transverse, roll-up, „L1“ peripheral ledge „L“ with an overlap, natur anodized aluminium, „L“ water connection at the left side (when installing the heat exchanger closer to the window, fans to the room) „5“ 24 V DC fans without controller (controller is not needed)

 **Trench heater heating output FRT 0110 0175**

Q[W] 75/65/20 °C (ΔT=50 °C)

Temperature exponent 1,1

Length L [mm]	Speed [-] / Heating output [W]			
	1	2	3	4 max.
700	89 W	197 W	255 W	306 W
800	118 W	262 W	340 W	408 W
900	142 W	315 W	409 W	490 W
1000	201 W	446 W	579 W	694 W
1100	201 W	446 W	579 W	694 W
1200	236 W	525 W	681 W	817 W
1300	260 W	577 W	749 W	899 W
1400	289 W	643 W	834 W	1 001 W
1500	319 W	708 W	919 W	1 103 W
1600	349 W	775 W	1 006 W	1 207 W
1700	349 W	775 W	1 006 W	1 207 W
1800	402 W	892 W	1 157 W	1 389 W
1900	438 W	972 W	1 261 W	1 513 W
2000	467 W	1 037 W	1 346 W	1 615 W
2100	491 W	1 090 W	1 415 W	1 697 W
2200	491 W	1 090 W	1 415 W	1 697 W
2300	550 W	1 221 W	1 585 W	1 901 W
2400	550 W	1 221 W	1 585 W	1 901 W
2500	585 W	1 300 W	1 687 W	2 024 W
2600	609 W	1 352 W	1 755 W	2 106 W
2700	632 W	1 404 W	1 823 W	2 187 W
2800	668 W	1 483 W	1 925 W	2 310 W
2900	698 W	1 550 W	2 012 W	2 414 W
3000	698 W	1 550 W	2 012 W	2 414 W
3200	787 W	1 747 W	2 267 W	2 720 W
3400	816 W	1 812 W	2 352 W	2 822 W
3600	899 W	1 996 W	2 591 W	3 108 W
3800	928 W	2 061 W	2 676 W	3 210 W
4000	981 W	2 179 W	2 829 W	3 394 W
4200	1 047 W	2 325 W	3 018 W	3 621 W
4400	1 100 W	2 442 W	3 169 W	3 803 W
4600	1 165 W	2 587 W	3 358 W	4 029 W
4800	1 189 W	2 640 W	3 427 W	4 111 W

Q[W] 55/45/20 °C (ΔT=30 °C)

Length L [mm]	Speed [-] / Heating output [W]			
	1	2	3	4 max.
700	51 W	112 W	145 W	174 W
800	67 W	149 W	194 W	233 W
900	81 W	180 W	233 W	279 W
1000	115 W	254 W	330 W	396 W
1100	115 W	254 W	330 W	396 W
1200	135 W	299 W	388 W	466 W
1300	148 W	329 W	427 W	513 W
1400	165 W	367 W	475 W	571 W
1500	182 W	404 W	524 W	629 W
1600	199 W	442 W	574 W	688 W
1700	199 W	442 W	574 W	688 W
1800	229 W	509 W	660 W	792 W
1900	250 W	554 W	719 W	863 W
2000	266 W	591 W	767 W	921 W
2100	280 W	621 W	807 W	967 W
2200	280 W	621 W	807 W	967 W
2300	314 W	696 W	904 W	1 084 W
2400	314 W	696 W	904 W	1 084 W
2500	334 W	741 W	962 W	1 154 W
2600	347 W	771 W	1 001 W	1 201 W
2700	360 W	800 W	1 039 W	1 247 W
2800	381 W	845 W	1 097 W	1 317 W
2900	398 W	884 W	1 147 W	1 376 W
3000	398 W	884 W	1 147 W	1 376 W
3200	449 W	996 W	1 292 W	1 551 W
3400	465 W	1 033 W	1 341 W	1 609 W
3600	513 W	1 138 W	1 477 W	1 772 W
3800	529 W	1 175 W	1 526 W	1 830 W
4000	559 W	1 242 W	1 613 W	1 935 W
4200	597 W	1 326 W	1 721 W	2 064 W
4400	627 W	1 392 W	1 807 W	2 168 W
4600	664 W	1 475 W	1 914 W	2 297 W
4800	678 W	1 505 W	1 954 W	2 344 W

75/65/20 °C → 75 °C inlet temperature, 65 °C outlet temp., 20 °C room temp. / **Output 90/70/20 °C** = ~ 1,22 x 75/65/20 °C / **Output 70/55/20 °C** = ~ 0,84 x 75/65/20 °C / Heating outputs in accordance with EN442 / Not listed heating outputs for lengths per 100 mm steps calculate linearly.

 **Acoustic pressure [dB(A)]**

Length L [mm]	Speed [-] / Acoustic pressure [dB(A)]												
	1	2	3	4 max.									
700	< 20 dB(A)	20 dB(A)	25 dB(A)	29 dB(A)									
800		21 dB(A)	26 dB(A)	30 dB(A)									
900				22 dB(A)	27 dB(A)	31 dB(A)							
1000		23 dB(A)	28 dB(A)			32 dB(A)							
1100						24 dB(A)	29 dB(A)	33 dB(A)					
1200				25 dB(A)	30 dB(A)			34 dB(A)					
1300								26 dB(A)	31 dB(A)	35 dB(A)			
1400		27 dB(A)	32 dB(A)							36 dB(A)			
1500										28 dB(A)	33 dB(A)	37 dB(A)	
1600						29 dB(A)	34 dB(A)					38 dB(A)	
1700	30 dB(A)											35 dB(A)	
1800													
1900													
2000													
2100													
2200													
2300													
2400													
2500													
2600													
2700													
2800													
2900													
3000													
3200													
3400													
3600													
3800													
4000													
4200													
4400													
4600													
4800													

Acoustic pressure level choose according to specific environment. More details on page 10

 **Fans input power [W]***

Length L [mm]	Speed [-] / Fans input power [W]*			
	1	2	3	4 max.
700	1 W	1 W	2 W	2 W
800	1 W	1 W	2 W	2 W
900	1 W	1 W	2 W	2 W
1000	2 W	2 W	2 W	3 W
1100	2 W	2 W	2 W	3 W
1200	2 W	3 W	3 W	4 W
1300	2 W	3 W	3 W	4 W
1400	3 W	3 W	4 W	5 W
1500	3 W	3 W	4 W	5 W
1600	3 W	3 W	4 W	5 W
1700	3 W	3 W	4 W	5 W
1800	3 W	3 W	4 W	5 W
1900	3 W	4 W	5 W	6 W
2000	4 W	5 W	6 W	7 W
2100	4 W	5 W	6 W	7 W
2200	4 W	5 W	6 W	7 W
2300	4 W	5 W	6 W	7 W
2400	4 W	5 W	6 W	7 W
2500	5 W	6 W	7 W	9 W
2600	5 W	6 W	7 W	9 W
2700	5 W	6 W	7 W	9 W
2800	5 W	6 W	7 W	9 W
2900	5 W	6 W	7 W	9 W
3000	5 W	6 W	7 W	9 W
3200	6 W	8 W	9 W	11 W
3400	6 W	8 W	9 W	11 W
3600	7 W	8 W	10 W	12 W
3800	7 W	9 W	11 W	13 W
4000	7 W	9 W	11 W	13 W
4200	7 W	9 W	11 W	13 W
4400	8 W	10 W	12 W	14 W
4600	8 W	10 W	12 W	15 W
4800	8 W	10 W	12 W	15 W

* Approximate fan input powers / **When using electrothermal actuator add in the trench heater's power 3 W** / Wiring of the trench heater → page 80

FRT 0110 0200

ECO & SAFE | VOLTAGE 24

TRENCH HEATER WITH FAN



- Flats, detached houses, offices, administrative buildings
- Narrow trench heater suitable for a standard floor
- High heating output
- Continuous speed control
- Quiet operation
- Common electricity consumption **3 W/m**
- Using in dry environment



Technical data

Trench heater

Height	H = 110 mm
Width	W = 200 mm
Length	L = 700-4 800 mm in step 100 mm

Heat exchanger

Type	Al-Cu lamellar
Length	L- 295 mm
Connection thread	2xG1/2" inner

Working conditions

Max. temperature	110 °C
Max. overpressure	1 MPa (10 bar)
Protection	IP 20
Ambient conditions	Temp. T = +2 to +40 °C Humidity Rh = 20 to 70 %

Variants

Transverse roll-up grilles

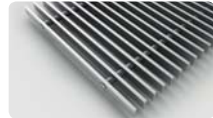

natur - anod. aluminium



bronze - anod. aluminium



black - anod. aluminium

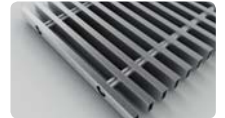

stainless



natur beech - wooden



stained beech - wooden



natur oak - wooden



stained oak - wooden

Linear non-rolling grilles



natur - anod. aluminium



bronze - anod. aluminium



black - anod. aluminium

Peripheral ledges



(more on page 7)

More possibilities and variants → page 6

Trench heater standard equipment

Trough	Galvanized steel trough with surface finish and black spray layer inside, black cover plates of connection
Heat exchanger	Al-Cu lamellar exchanger with air vent valve, black painted
Grille	Design walkable grille according to the customer's choice*
Ledge	Made of anodized aluminium, type and colour according to the customer's choice
Fan	Modern tangential fan with 24 V DC EC motor with high efficiency, rotors protection
Assembly elements	Leveling screws for setting up the trough, mounting brackets
Manual	Manual for the progress of work during installation and user manual
Wiring	Electrical wiring diagram of the trench heaters
Mounting board	Cover and the spacer particle board for easy installation
Package	Transport package for protection against damage during transportation and handling

*stainless grilles surcharge

Accessories per order

	Room thermostat		Power supply
	Electrothermal actuator		Thermostatic valve
	Lockshield valve		

Accessories details → page 11

Technical drawing

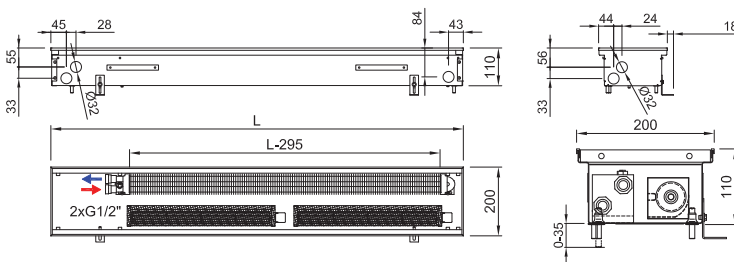

Connection to heating system

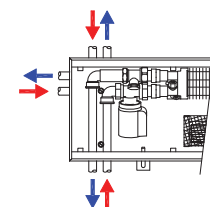

The hydraulic parameters of the heat exchanger → page 78

Code example: FRT 0110 0200 1900 C 52 J1 R - 5

Trench heater FRT H = **110** mm, W = **200** mm, L = **1 900** mm, „C“ Galvanized steel trough with black inside, heat exchanger and inner parts painted black, „52“ stainless grille, transverse, roll-up, „J1“ peripheral ledge „J“, natur anodized aluminium, „R“ water connection at the right side (when installing the heat exchanger closer to the window, fans to the room), „5“ 24 V DC fans without controller (controller is not needed)

 **Trench heater heating output FRT 0110 0200**

Q[W] 75/65/20 °C (ΔT=50 °C)

Temperature exponent 1,1

Length L [mm]	Speed [-] / Heating output [W]			
	1	2	3	4 max.
700	171 W	376 W	500 W	537 W
800	228 W	502 W	666 W	716 W
900	273 W	602 W	800 W	860 W
1000	387 W	853 W	1 133 W	1 218 W
1100	387 W	853 W	1 133 W	1 218 W
1200	456 W	1 003 W	1 333 W	1 433 W
1300	501 W	1 104 W	1 466 W	1 576 W
1400	558 W	1 229 W	1 633 W	1 755 W
1500	615 W	1 355 W	1 799 W	1 934 W
1600	670 W	1 475 W	1 959 W	2 106 W
1700	670 W	1 475 W	1 959 W	2 106 W
1800	775 W	1 706 W	2 266 W	2 436 W
1900	841 W	1 851 W	2 459 W	2 643 W
2000	898 W	1 977 W	2 625 W	2 822 W
2100	943 W	2 077 W	2 759 W	2 966 W
2200	943 W	2 077 W	2 759 W	2 966 W
2300	1 057 W	2 328 W	3 092 W	3 324 W
2400	1 057 W	2 328 W	3 092 W	3 324 W
2500	1 126 W	2 478 W	3 292 W	3 539 W
2600	1 171 W	2 579 W	3 425 W	3 682 W
2700	1 217 W	2 679 W	3 558 W	3 825 W
2800	1 285 W	2 830 W	3 758 W	4 040 W
2900	1 340 W	2 950 W	3 918 W	4 212 W
3000	1 340 W	2 950 W	3 918 W	4 212 W
3200	1 511 W	3 326 W	4 418 W	4 749 W
3400	1 568 W	3 452 W	4 584 W	4 928 W
3600	1 727 W	3 803 W	5 051 W	5 430 W
3800	1 784 W	3 928 W	5 217 W	5 609 W
4000	1 887 W	4 154 W	5 517 W	5 931 W
4200	2 010 W	4 425 W	5 877 W	6 318 W
4400	2 115 W	4 656 W	6 184 W	6 648 W
4600	2 238 W	4 927 W	6 543 W	7 034 W
4800	2 283 W	5 027 W	6 677 W	7 178 W

Q[W] 55/45/20 °C (ΔT=30 °C)

Length L [mm]	Speed [-] / Heating output [W]			
	1	2	3	4 max.
700	97 W	214 W	285 W	306 W
800	130 W	286 W	380 W	408 W
900	156 W	343 W	456 W	490 W
1000	221 W	486 W	646 W	694 W
1100	221 W	486 W	646 W	694 W
1200	260 W	572 W	760 W	817 W
1300	286 W	629 W	836 W	899 W
1400	318 W	701 W	931 W	1 001 W
1500	351 W	773 W	1 026 W	1 103 W
1600	382 W	841 W	1 117 W	1 201 W
1700	382 W	841 W	1 117 W	1 201 W
1800	442 W	973 W	1 292 W	1 389 W
1900	479 W	1 055 W	1 402 W	1 507 W
2000	512 W	1 127 W	1 497 W	1 609 W
2100	538 W	1 184 W	1 573 W	1 691 W
2200	538 W	1 184 W	1 573 W	1 691 W
2300	603 W	1 327 W	1 763 W	1 895 W
2400	603 W	1 327 W	1 763 W	1 895 W
2500	642 W	1 413 W	1 877 W	2 018 W
2600	668 W	1 470 W	1 953 W	2 099 W
2700	694 W	1 527 W	2 028 W	2 181 W
2800	733 W	1 613 W	2 143 W	2 303 W
2900	764 W	1 682 W	2 234 W	2 401 W
3000	764 W	1 682 W	2 234 W	2 401 W
3200	861 W	1 896 W	2 519 W	2 708 W
3400	894 W	1 968 W	2 613 W	2 810 W
3600	985 W	2 168 W	2 880 W	3 096 W
3800	1 017 W	2 239 W	2 974 W	3 198 W
4000	1 076 W	2 368 W	3 145 W	3 381 W
4200	1 146 W	2 523 W	3 351 W	3 602 W
4400	1 206 W	2 654 W	3 526 W	3 790 W
4600	1 276 W	2 809 W	3 730 W	4 010 W
4800	1 302 W	2 866 W	3 807 W	4 092 W

75/65/20 °C → 75 °C inlet temperature, 65 °C outlet temp., 20 °C room temp. / **Output 90/70/20 °C** = ~ 1,22 x 75/65/20 °C / **Output 70/55/20 °C** = ~ 0,84 x 75/65/20 °C / Heating outputs in accordance with EN442 / Not listed heating outputs for lengths per 100 mm steps calculate linearly.

 **Acoustic pressure [dB(A)]**

Length L [mm]	Speed [-] / Acoustic pressure [dB(A)]					
	1	2	3	4 max.		
700	< 20 dB(A)	26 dB(A)	34 dB(A)	37 dB(A)		
800		27 dB(A)	35 dB(A)	38 dB(A)		
900						
1000		28 dB(A)	36 dB(A)	39 dB(A)		
1100						
1200						
1300		29 dB(A)	37 dB(A)	40 dB(A)		
1400						
1500						
1600						
1700	20 dB(A)	38 dB(A)	41 dB(A)			
1800						
1900						
2000						
2100						
2200	21 dB(A)	39 dB(A)	42 dB(A)			
2300						
2400						
2500						
2600						
2700						
2800	22 dB(A)	40 dB(A)	43 dB(A)			
2900						
3000						
3200						
3400						
3600						
3800						
4000	23 dB(A)	31 dB(A)	44 dB(A)			
4200						
4400						
4600						
4800						
				24 dB(A)	32 dB(A)	45 dB(A)
	25 dB(A)	33 dB(A)	46 dB(A)			
	26 dB(A)	34 dB(A)	47 dB(A)			

Acoustic pressure level choose according to specific environment. More details on page 10

 **Fans input power [W]***

Length L [mm]	Speed [-] / Fans input power [W]*			
	1	2	3	4 max.
700	1 W	2 W	2 W	3 W
800	2 W	2 W	3 W	4 W
900	2 W	3 W	4 W	5 W
1000	2 W	3 W	5 W	6 W
1100	2 W	3 W	5 W	6 W
1200	3 W	4 W	6 W	8 W
1300	3 W	5 W	7 W	9 W
1400	3 W	5 W	7 W	9 W
1500	4 W	6 W	8 W	10 W
1600	4 W	6 W	8 W	10 W
1700	4 W	6 W	9 W	11 W
1800	5 W	7 W	10 W	12 W
1900	5 W	7 W	10 W	12 W
2000	5 W	7 W	10 W	13 W
2100	5 W	8 W	11 W	14 W
2200	5 W	8 W	11 W	14 W
2300	6 W	9 W	13 W	16 W
2400	6 W	9 W	13 W	16 W
2500	6 W	9 W	14 W	17 W
2600	7 W	10 W	14 W	18 W
2700	7 W	11 W	15 W	19 W
2800	7 W	11 W	15 W	19 W
2900	7 W	11 W	15 W	19 W
3000	8 W	11 W	16 W	20 W
3200	8 W	12 W	18 W	22 W
3400	9 W	13 W	18 W	23 W
3600	9 W	14 W	20 W	25 W
3800	10 W	14 W	21 W	26 W
4000	11 W	16 W	23 W	28 W
4200	11 W	16 W	23 W	28 W
4400	12 W	17 W	25 W	31 W
4600	12 W	18 W	26 W	32 W
4800	12 W	18 W	27 W	33 W

* Approximate fan input powers / **When using electrothermal actuator add in the trench heater's power 3 W** / Wiring of the trench heater → page 80

FRT 0110 0250

ECO & SAFE | **VOLTAGE 24**

TRENCH HEATER WITH FAN



- Flats, detached houses, offices, administrative buildings
- Narrow trench heater suitable for a standard floor
- High heating output
- Continuous speed control
- Quiet operation
- Common electricity consumption **3 W/m**
- Using in dry environment

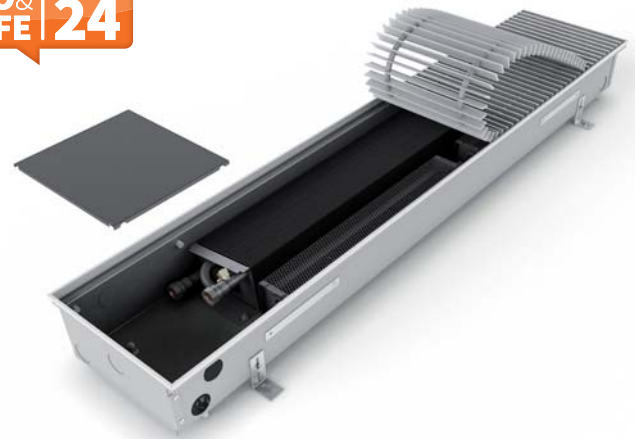

Technical data

Trench heater

Height	H = 110 mm
Width	W = 250 mm
Length	L = 700-4 800 mm in step 100 mm

Heat exchanger

Type	Al-Cu lamellar
Length	L- 295 mm
Connection thread	2xG1/2" inner

Working conditions

Max. temperature	110 °C
Max. overpressure	1 MPa (10 bar)
Protection	IP 20

Ambient conditions	Temp. T = +2 to +40 °C Humidity Rh = 20 to 70 %
--------------------	--

Variants

Transverse roll-up grilles



natur - anod. aluminium



bronze - anod. aluminium



black - anod. aluminium

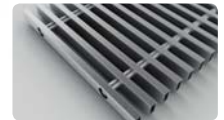

stainless



natur beech - wooden



stained beech - wooden



natur oak - wooden



stained oak - wooden

Linear non-rolling grilles



natur - anod. aluminium



bronze - anod. aluminium



black - anod. aluminium

Peripheral ledges



(more on page 7)

More possibilities and variants → page 6

Trench heater standard equipment

Trough	Galvanized steel trough with surface finish and black spray layer inside, black cover plates of connection
Heat exchanger	Al-Cu lamellar exchanger with air vent valve, black painted
Grille	Design walkable grille according the customer's choice*
Ledge	Made of anodized aluminium, type and colour according the customer's choice
Fan	Modern tangential fan with 24 V DC EC motor with high efficiency, rotors protection
Assembly elements	Leveling screws for setting up the trough, mounting brackets
Manual	Manual for the progress of work during installation and user manual
Wiring	Electrical wiring diagram of the trench heaters
Mounting board	Cover and the spacer particle board for easy installation
Package	Transport package for protection against damage during transportation and handling

*stainless grilles surcharge

Accessories per order

	Room thermostat		Power supply
	Electrothermal actuator		Thermostatic valve
	Lockshield valve		

Accessories details → page 11

Technical drawing

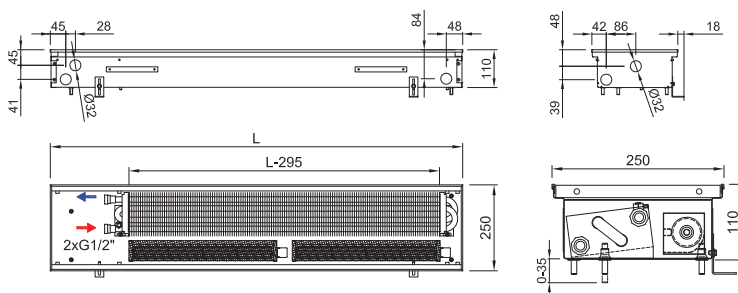

Connection to heating system

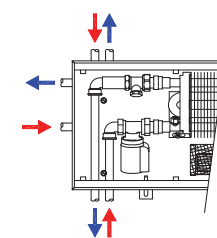

The hydraulic parameters of the heat exchanger → page 78

Code example: FRT 00110 0250 1500 C 62 L2 L - 5

Trench heater FRT H=110 mm, W= 250 mm, L=1 500 mm, „C“ Galvanized steel trough with black inside, heat exchanger and inner parts painted black, „62“ stained beech grille, transverse, roll-up, „L2“ peripheral ledge „L“ with an overlap, bronze anodized aluminium, „L“ water connection at the left side (when installing the heat exchanger closer to the window, fans to the room) „5“ 24 V DC fans without controller (controller is not needed)

 **Trench heater heating output FRT 0110 0250**

Q[W] 75/65/20 °C (ΔT=50 °C)

Temperature exponent 1,1

Length L [mm]	Speed [-] / Heating output [W]			
	1	2	3	4 max.
700	288 W	594 W	790 W	851 W
800	384 W	792 W	1 053 W	1 135 W
900	461 W	950 W	1 264 W	1 362 W
1000	653 W	1 346 W	1 790 W	1 930 W
1100	653 W	1 346 W	1 790 W	1 930 W
1200	768 W	1 584 W	2 106 W	2 271 W
1300	845 W	1 742 W	2 317 W	2 498 W
1400	941 W	1 940 W	2 580 W	2 781 W
1500	1 037 W	2 138 W	2 844 W	3 065 W
1600	1 129 W	2 328 W	3 096 W	3 338 W
1700	1 129 W	2 328 W	3 096 W	3 338 W
1800	1 306 W	2 692 W	3 581 W	3 860 W
1900	1 417 W	2 922 W	3 886 W	4 189 W
2000	1 513 W	3 120 W	4 150 W	4 473 W
2100	1 590 W	3 278 W	4 360 W	4 700 W
2200	1 590 W	3 278 W	4 360 W	4 700 W
2300	1 782 W	3 674 W	4 887 W	5 268 W
2400	1 782 W	3 674 W	4 887 W	5 268 W
2500	1 898 W	3 911 W	5 203 W	5 608 W
2600	1 974 W	4 070 W	5 413 W	5 835 W
2700	2 051 W	4 228 W	5 624 W	6 062 W
2800	2 166 W	4 466 W	5 940 W	6 403 W
2900	2 259 W	4 656 W	6 193 W	6 676 W
3000	2 259 W	4 656 W	6 193 W	6 676 W
3200	2 547 W	5 249 W	6 983 W	7 527 W
3400	2 643 W	5 447 W	7 246 W	7 811 W
3600	2 912 W	6 002 W	7 983 W	8 606 W
3800	3 008 W	6 200 W	8 247 W	8 889 W
4000	3 180 W	6 556 W	8 721 W	9 400 W
4200	3 388 W	6 983 W	9 289 W	10 013 W
4400	3 565 W	7 348 W	9 774 W	10 536 W
4600	3 772 W	7 775 W	10 342 W	11 149 W
4800	3 849 W	7 933 W	10 553 W	11 376 W

Q[W] 55/45/20 °C (ΔT=30 °C)

Length L [mm]	Speed [-] / Heating output [W]			
	1	2	3	4 max.
700	164 W	339 W	450 W	485 W
800	219 W	452 W	600 W	647 W
900	263 W	542 W	721 W	777 W
1000	372 W	767 W	1 021 W	1 100 W
1100	372 W	767 W	1 021 W	1 100 W
1200	438 W	903 W	1 201 W	1 295 W
1300	482 W	993 W	1 321 W	1 424 W
1400	536 W	1 106 W	1 471 W	1 586 W
1500	591 W	1 219 W	1 621 W	1 747 W
1600	644 W	1 327 W	1 765 W	1 903 W
1700	644 W	1 327 W	1 765 W	1 903 W
1800	745 W	1 535 W	2 042 W	2 201 W
1900	808 W	1 666 W	2 215 W	2 388 W
2000	863 W	1 779 W	2 366 W	2 550 W
2100	906 W	1 869 W	2 486 W	2 680 W
2200	906 W	1 869 W	2 486 W	2 680 W
2300	1 016 W	2 095 W	2 786 W	3 003 W
2400	1 016 W	2 095 W	2 786 W	3 003 W
2500	1 082 W	2 230 W	2 966 W	3 197 W
2600	1 125 W	2 320 W	3 086 W	3 327 W
2700	1 169 W	2 410 W	3 206 W	3 456 W
2800	1 235 W	2 546 W	3 387 W	3 650 W
2900	1 288 W	2 654 W	3 531 W	3 806 W
3000	1 288 W	2 654 W	3 531 W	3 806 W
3200	1 452 W	2 993 W	3 981 W	4 291 W
3400	1 507 W	3 105 W	4 131 W	4 453 W
3600	1 660 W	3 422 W	4 551 W	4 906 W
3800	1 715 W	3 535 W	4 702 W	5 068 W
4000	1 813 W	3 738 W	4 972 W	5 359 W
4200	1 932 W	3 981 W	5 296 W	5 709 W
4400	2 032 W	4 189 W	5 572 W	6 007 W
4600	2 150 W	4 433 W	5 896 W	6 356 W
4800	2 194 W	4 523 W	6 016 W	6 486 W

75/65/20 °C → 75 °C inlet temperature, 65 °C outlet temp., 20 °C room temp. / Output 90/70/20 °C = ~ 1,22 x 75/65/20 °C / Output 70/55/20 °C = ~ 0,84 x 75/65/20 °C / Heating outputs in accordance with EN442 / Not listed heating outputs for lengths per 100 mm steps calculate linearly.

 **Acoustic pressure [dB(A)]**

Length L [mm]	Speed [-] / Acoustic pressure [dB(A)]					
	1	2	3	4 max.		
700	< 20 dB(A)	26 dB(A)	34 dB(A)	37 dB(A)		
800		27 dB(A)	35 dB(A)	38 dB(A)		
900						
1000		28 dB(A)	36 dB(A)	39 dB(A)		
1100						
1200						
1300		29 dB(A)	37 dB(A)	40 dB(A)		
1400						
1500						
1600						
1700	20 dB(A)	38 dB(A)	41 dB(A)			
1800						
1900						
2000						
2100						
2200	21 dB(A)	39 dB(A)	42 dB(A)			
2300						
2400						
2500						
2600						
2700						
2800	22 dB(A)	40 dB(A)	43 dB(A)			
2900						
3000						
3200						
3400						
3600						
3800				23 dB(A)	41 dB(A)	44 dB(A)
4000						
4200						
4400						
4600						
4800						
4800	24 dB(A)	42 dB(A)	45 dB(A)			
4800						
4800						
4800						
4800						
4800						
4800						
4800						
4800						
4800	25 dB(A)	43 dB(A)	46 dB(A)			
4800						
4800						
4800						
4800						
4800						
4800						
4800						
4800						
4800						
4800	26 dB(A)	44 dB(A)	47 dB(A)			
4800						
4800						
4800						
4800						
4800						
4800						
4800						
4800						
4800						
4800						

Acoustic pressure level choose according to specific environment. More details on page 10

 **Fans input power [W]***

Length L [mm]	Speed [-] / Fans input power [W]*			
	1	2	3	4 max.
700	1 W	2 W	2 W	3 W
800	2 W	2 W	3 W	4 W
900	2 W	3 W	4 W	5 W
1000	2 W	3 W	5 W	6 W
1100	2 W	3 W	5 W	6 W
1200	3 W	4 W	6 W	8 W
1300	3 W	5 W	7 W	9 W
1400	3 W	5 W	7 W	9 W
1500	4 W	6 W	8 W	10 W
1600	4 W	6 W	8 W	10 W
1700	4 W	6 W	9 W	11 W
1800	5 W	7 W	10 W	12 W
1900	5 W	7 W	10 W	12 W
2000	5 W	7 W	10 W	13 W
2100	5 W	8 W	11 W	14 W
2200	5 W	8 W	11 W	14 W
2300	6 W	9 W	13 W	16 W
2400	6 W	9 W	13 W	16 W
2500	6 W	9 W	14 W	17 W
2600	7 W	10 W	14 W	18 W
2700	7 W	11 W	15 W	19 W
2800	7 W	11 W	15 W	19 W
2900	7 W	11 W	15 W	19 W
3000	8 W	11 W	16 W	20 W
3200	8 W	12 W	18 W	22 W
3400	9 W	13 W	18 W	23 W
3600	9 W	14 W	20 W	25 W
3800	10 W	14 W	21 W	26 W
4000	11 W	16 W	23 W	28 W
4200	11 W	16 W	23 W	28 W
4400	12 W	17 W	25 W	31 W
4600	12 W	18 W	26 W	32 W
4800	12 W	18 W	27 W	33 W

* Approximate fan input powers / When using electrothermal actuator add in the trench heater's power 3 W / Wiring of the trench heater → page 80

FRT 0110 0300

ECO & SAFE | **VOLTAGE 24**

TRENCH HEATER WITH FAN



- Flats, detached houses, offices, administrative buildings
- Universal trench heater suitable for a standard floor
- High heating output
- Continuous speed control
- Quiet operation
- Common electricity consumption **3 W/m**
- Using in dry environment



Technical data

Trench heater

Height	H = 110 mm
Width	W = 300 mm
Length	L = 700-4 800 mm in step 100 mm

Heat exchanger

Type	Al-Cu lamellar
Length	L- 295 mm
Connection thread	2xG1/2" inner

Working conditions

Max. temperature	110 °C
Max. overpressure	1 MPa (10 bar)
Protection	IP 20
Ambient conditions	Temp. T = +2 to +40 °C Humidity Rh = 20 to 70 %

Variants

Transverse roll-up grilles



natur - anod. aluminium



bronze - anod. aluminium



black - anod. aluminium

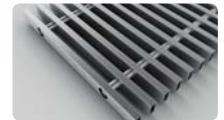

stainless



natur beech - wooden



stained beech - wooden



natur oak - wooden



stained oak - wooden

Linear non-rolling grilles



natur - anod. aluminium



bronze - anod. aluminium



black - anod. aluminium

Peripheral ledges



(more on page 7)

More possibilities and variants → page 6

Trench heater standard equipment

Trough	Galvanized steel trough with surface finish and black spray layer inside, black cover plates of connection
Heat exchanger	Al-Cu lamellar exchanger with air vent valve, black painted
Grille	Design walkable grille according the customer's choice*
Ledge	Made of anodized aluminium, type and colour according the customer's choice
Fan	Modern tangential fan with 24 V DC EC motor with high efficiency, rotors protection
Assembly elements	Leveling screws for setting up the trough, mounting brackets
Manual	Manual for the progress of work during installation and user manual
Wiring	Electrical wiring diagram of the trench heaters
Mounting board	Cover and the spacer particle board for easy installation
Package	Transport package for protection against damage during transportation and handling

*stainless grilles surcharge

Accessories per order

	Room thermostat		Power supply
	Electrothermal actuator		Thermostatic valve
	Lockshield valve		

Accessories details → page 11

Technical drawing

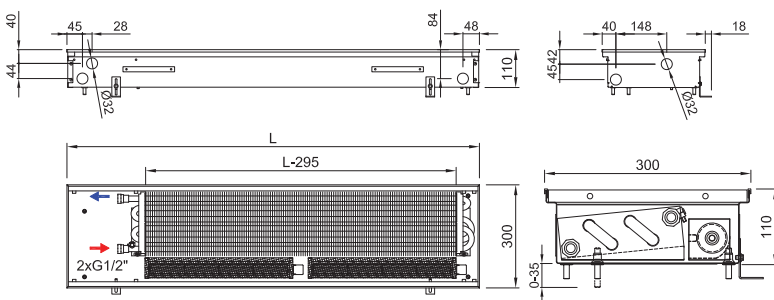

Connection to heating system

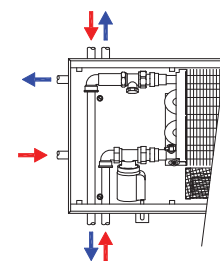

The hydraulic parameters of the heat exchanger → page 78

Code example: FRT 0110 0300 2700 C 32 J3 R - 5

Trench heater FRT H=110 mm, W= 300 mm, L=2 700 mm, „C“ Galvanized steel trough with black inside, heat exchanger and inner parts painted black, „32“ black anodized aluminium grille, linear, rigid, „J3“ peripheral ledge „J“, black anodized aluminium, „R“ water connection at the right side (when installing the heat exchanger closer to the window, fans to the room), „5“ 24 V DC fans without controller (controller is not needed)

 **Trench heater heating output FRT 0110 0300**

Q[W] 75/65/20 °C (ΔT=50 °C)

Temperature exponent 1,1

Length L [mm]	Speed [-] / Heating output [W]			
	1	2	3	4 max.
700	307 W	637 W	864 W	933 W
800	409 W	849 W	1 152 W	1 244 W
900	491 W	1 019 W	1 382 W	1 493 W
1000	695 W	1 443 W	1 958 W	2 115 W
1100	695 W	1 443 W	1 958 W	2 115 W
1200	818 W	1 698 W	2 304 W	2 488 W
1300	899 W	1 867 W	2 534 W	2 737 W
1400	1 002 W	2 080 W	2 822 W	3 048 W
1500	1 104 W	2 292 W	3 110 W	3 359 W
1600	1 202 W	2 496 W	3 387 W	3 658 W
1700	1 202 W	2 496 W	3 387 W	3 658 W
1800	1 390 W	2 886 W	3 916 W	4 230 W
1900	1 509 W	3 132 W	4 251 W	4 591 W
2000	1 611 W	3 344 W	4 539 W	4 902 W
2100	1 693 W	3 514 W	4 769 W	5 151 W
2200	1 693 W	3 514 W	4 769 W	5 151 W
2300	1 897 W	3 939 W	5 345 W	5 773 W
2400	1 897 W	3 939 W	5 345 W	5 773 W
2500	2 020 W	4 193 W	5 690 W	6 146 W
2600	2 101 W	4 363 W	5 921 W	6 395 W
2700	2 183 W	4 533 W	6 151 W	6 644 W
2800	2 306 W	4 787 W	6 497 W	7 017 W
2900	2 404 W	4 991 W	6 773 W	7 315 W
3000	2 404 W	4 991 W	6 773 W	7 315 W
3200	2 711 W	5 628 W	7 637 W	8 249 W
3400	2 813 W	5 840 W	7 925 W	8 560 W
3600	3 099 W	6 434 W	8 731 W	9 430 W
3800	3 201 W	6 646 W	9 019 W	9 741 W
4000	3 385 W	7 028 W	9 538 W	10 301 W
4200	3 606 W	7 487 W	10 160 W	10 973 W
4400	3 794 W	7 877 W	10 690 W	11 545 W
4600	4 015 W	8 335 W	11 312 W	12 217 W
4800	4 096 W	8 505 W	11 542 W	12 466 W

75/65/20 °C → 75 °C inlet temperature, 65 °C outlet temp., 20 °C room temp. / Output 90/70/20 °C = ~ 1,22 x 75/65/20 °C / Output 70/55/20 °C = ~ 0,84 x 75/65/20 °C / Heating outputs in accordance with EN442 / Not listed heating outputs for lengths per 100 mm steps calculate linearly.

Q[W] 55/45/20 °C (ΔT=30 °C)

Length L [mm]	Speed [-] / Heating output [W]			
	1	2	3	4 max.
700	175 W	363 W	493 W	532 W
800	233 W	484 W	657 W	709 W
900	280 W	581 W	788 W	851 W
1000	396 W	823 W	1 116 W	1 206 W
1100	396 W	823 W	1 116 W	1 206 W
1200	466 W	968 W	1 314 W	1 418 W
1300	513 W	1 064 W	1 445 W	1 560 W
1400	571 W	1 186 W	1 609 W	1 738 W
1500	629 W	1 307 W	1 773 W	1 915 W
1600	685 W	1 423 W	1 931 W	2 085 W
1700	685 W	1 423 W	1 931 W	2 085 W
1800	792 W	1 645 W	2 233 W	2 412 W
1900	860 W	1 786 W	2 424 W	2 617 W
2000	918 W	1 906 W	2 588 W	2 795 W
2100	965 W	2 003 W	2 719 W	2 937 W
2200	965 W	2 003 W	2 719 W	2 937 W
2300	1 082 W	2 246 W	3 047 W	3 291 W
2400	1 082 W	2 246 W	3 047 W	3 291 W
2500	1 152 W	2 391 W	3 244 W	3 504 W
2600	1 198 W	2 487 W	3 376 W	3 646 W
2700	1 245 W	2 584 W	3 507 W	3 788 W
2800	1 315 W	2 729 W	3 704 W	4 001 W
2900	1 371 W	2 845 W	3 861 W	4 170 W
3000	1 371 W	2 845 W	3 861 W	4 170 W
3200	1 546 W	3 209 W	4 354 W	4 703 W
3400	1 604 W	3 330 W	4 518 W	4 880 W
3600	1 767 W	3 668 W	4 978 W	5 376 W
3800	1 825 W	3 789 W	5 142 W	5 554 W
4000	1 930 W	4 007 W	5 438 W	5 873 W
4200	2 056 W	4 268 W	5 792 W	6 256 W
4400	2 163 W	4 491 W	6 095 W	6 582 W
4600	2 289 W	4 752 W	6 449 W	6 965 W
4800	2 335 W	4 849 W	6 580 W	7 107 W

 **Acoustic pressure [dB(A)]**

Length L [mm]	Speed [-] / Acoustic pressure [dB(A)]																
	1	2	3	4 max.													
700	< 20 dB(A)	26 dB(A)	34 dB(A)	37 dB(A)													
800		27 dB(A)	35 dB(A)	38 dB(A)													
900			36 dB(A)	39 dB(A)													
1000		37 dB(A)		40 dB(A)													
1100				38 dB(A)	41 dB(A)												
1200			39 dB(A)		42 dB(A)												
1300					30 dB(A)	43 dB(A)											
1400		40 dB(A)				44 dB(A)											
1500						41 dB(A)	45 dB(A)										
1600				42 dB(A)			46 dB(A)										
1700	31 dB(A)						43 dB(A)										
1800			40 dB(A)				44 dB(A)										
1900							41 dB(A)	45 dB(A)									
2000					42 dB(A)			46 dB(A)									
2100								20 dB(A)	43 dB(A)								
2200		30 dB(A)							44 dB(A)								
2300									40 dB(A)	45 dB(A)							
2400						41 dB(A)				46 dB(A)							
2500										21 dB(A)	43 dB(A)						
2600				31 dB(A)							44 dB(A)						
2700											40 dB(A)	45 dB(A)					
2800	41 dB(A)											46 dB(A)					
2900												42 dB(A)	47 dB(A)				
3000			32 dB(A)										43 dB(A)				
3200													40 dB(A)	44 dB(A)			
3400							41 dB(A)							45 dB(A)			
3600														33 dB(A)	43 dB(A)		
3800					40 dB(A)										44 dB(A)		
4000															41 dB(A)	45 dB(A)	
4200								34 dB(A)								43 dB(A)	
4400																41 dB(A)	44 dB(A)
4600		25 dB(A)															43 dB(A)
4800																	36 dB(A)

Acoustic pressure level choose according to specific environment. More details on page 10

 **Fans input power [W]***

Length L [mm]	Speed [-] / Fans input power [W]*			
	1	2	3	4 max.
700	1 W	2 W	2 W	3 W
800	2 W	2 W	3 W	4 W
900	2 W	3 W	4 W	5 W
1000	2 W	3 W	5 W	6 W
1100	2 W	3 W	5 W	6 W
1200	3 W	4 W	6 W	8 W
1300	3 W	5 W	7 W	9 W
1400	3 W	5 W	7 W	9 W
1500	4 W	6 W	8 W	10 W
1600	4 W	6 W	8 W	10 W
1700	4 W	6 W	9 W	11 W
1800	5 W	7 W	10 W	12 W
1900	5 W	7 W	10 W	12 W
2000	5 W	7 W	10 W	13 W
2100	5 W	8 W	11 W	14 W
2200	5 W	8 W	11 W	14 W
2300	6 W	9 W	13 W	16 W
2400	6 W	9 W	13 W	16 W
2500	6 W	9 W	14 W	17 W
2600	7 W	10 W	14 W	18 W
2700	7 W	11 W	15 W	19 W
2800	7 W	11 W	15 W	19 W
2900	7 W	11 W	15 W	19 W
3000	8 W	11 W	16 W	20 W
3200	8 W	12 W	18 W	22 W
3400	9 W	13 W	18 W	23 W
3600	9 W	14 W	20 W	25 W
3800	10 W	14 W	21 W	26 W
4000	11 W	16 W	23 W	28 W
4200	11 W	16 W	23 W	28 W
4400	12 W	17 W	25 W	31 W
4600	12 W	18 W	26 W	32 W
4800	12 W	18 W	27 W	33 W

* Approximate fan input powers / When using electrothermal actuator add in the trench heater's power 3 W / Wiring of the trench heater → page 80

FRT 0110 0425

ECO & SAFE | **VOLTAGE 24**

TRENCH HEATER WITH FAN



- Flats, detached houses, offices, administrative buildings
- Suitable for low-temperature systems
- High heating output
- Continuous speed control
- Quiet operation
- Common electricity consumption **3 W/m**
- Using in dry environment



Technical data

Trench heater

Height	H = 110 mm
Width	W = 425 mm
Length	L = 700-4 800 mm in step 100 mm

Heat exchanger

Type	Al-Cu lamellar
Length	L- 295 mm
Connection thread	2xG1/2" inner

Working conditions

Max. temperature	110 °C
Max. overpressure	1 MPa (10 bar)
Protection	IP 20

Ambient conditions	Temp. T = +2 to +40 °C Humidity Rh = 20 to 70 %
--------------------	--

Variants

Transverse roll-up grilles

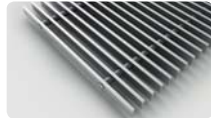

natur - anod. aluminium



bronze - anod. aluminium



black - anod. aluminium

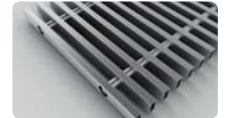

stainless



natur beech - wooden



stained beech - wooden



natur oak - wooden



stained oak - wooden

Linear non-rolling grilles



natur - anod. aluminium



bronze - anod. aluminium



black - anod. aluminium

Peripheral ledges



(more on page 7)

More possibilities and variants → page 6

Trench heater standard equipment

Trough	Galvanized steel trough with surface finish and black spray layer inside, black cover plates of connection
Heat exchanger	Al-Cu lamellar exchanger with air vent valve, black painted
Grille	Design walkable grille according the customer's choice*
Ledge	Made of anodized aluminium, type and colour according the customer's choice
Fan	Modern tangential fan with 24 V DC EC motor with high efficiency, rotors protection
Assembly elements	Leveling screws for setting up the trough, mounting brackets
Manual	Manual for the progress of work during installation and user manual
Wiring	Electrical wiring diagram of the trench heaters
Mounting board	Cover and the spacer particle board for easy installation
Package	Transport package for protection against damage during transportation and handling

*stainless grilles surcharge

Accessories per order

	Room thermostat		Power supply
	Electrothermal actuator		Thermostatic valve
	Lockshield valve		

Accessories details → page 11

Technical drawing

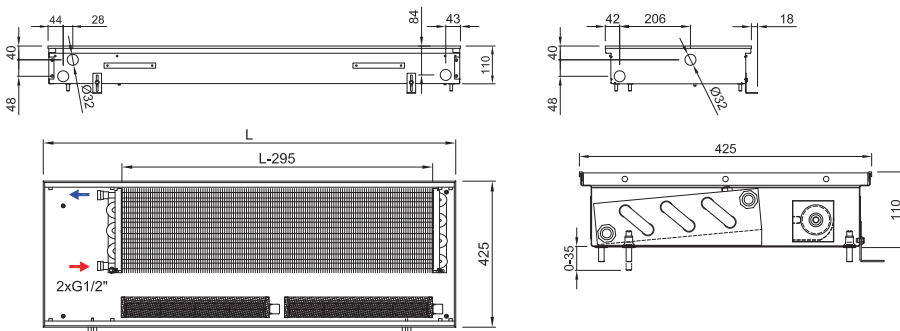

Connection to heating system

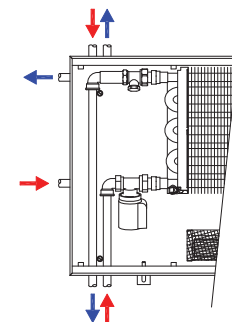

The hydraulic parameters of the heat exchanger → page 78

Code example: FRT 0110 0425 4400 C 64 L2 L - 5

Trench heater FRT H = **110** mm, W = **425** mm, L = **4 400** mm, „C“ Galvanized steel trough with black inside, heat exchanger and inner parts painted black, „64“ stained oak grille, transverse, roll-up, „L2“ peripheral ledge, „L“ with an overlap, bronze anodized aluminium, „L“ water connection at the left side (when installing the heat exchanger closer to the window, fans to the room) „5“ 24 V DC fans without controller (controller is not needed)

Trench heater heating output FRT 0110 0425

Q[W] 75/65/20 °C (ΔT=50 °C)

Temperature exponent 1,1

Length L [mm]	Speed [-] / Heating output [W]			
	1	2	3	4 max.
700	409 W	776 W	1 027 W	1 106 W
800	546 W	1 034 W	1 369 W	1 474 W
900	655 W	1 241 W	1 643 W	1 769 W
1000	928 W	1 758 W	2 328 W	2 506 W
1100	928 W	1 758 W	2 328 W	2 506 W
1200	1 092 W	2 068 W	2 738 W	2 948 W
1300	1 201 W	2 275 W	3 012 W	3 243 W
1400	1 337 W	2 534 W	3 354 W	3 612 W
1500	1 474 W	2 792 W	3 697 W	3 980 W
1600	1 605 W	3 040 W	4 025 W	4 334 W
1700	1 605 W	3 040 W	4 025 W	4 334 W
1800	1 856 W	3 516 W	4 655 W	5 012 W
1900	2 014 W	3 816 W	5 052 W	5 440 W
2000	2 151 W	4 075 W	5 394 W	5 808 W
2100	2 260 W	4 281 W	5 668 W	6 103 W
2200	2 260 W	4 281 W	5 668 W	6 103 W
2300	2 533 W	4 799 W	6 353 W	6 840 W
2400	2 533 W	4 799 W	6 353 W	6 840 W
2500	2 696 W	5 109 W	6 764 W	7 282 W
2600	2 806 W	5 316 W	7 037 W	7 577 W
2700	2 915 W	5 522 W	7 311 W	7 872 W
2800	3 079 W	5 833 W	7 722 W	8 314 W
2900	3 210 W	6 081 W	8 051 W	8 668 W
3000	3 210 W	6 081 W	8 051 W	8 668 W
3200	3 619 W	6 857 W	9 077 W	9 774 W
3400	3 755 W	7 115 W	9 420 W	10 142 W
3600	4 137 W	7 839 W	10 378 W	11 174 W
3800	4 274 W	8 098 W	10 720 W	11 543 W
4000	4 520 W	8 563 W	11 336 W	12 206 W
4200	4 814 W	9 121 W	12 076 W	13 002 W
4400	5 065 W	9 597 W	12 706 W	13 680 W
4600	5 360 W	10 156 W	13 445 W	14 476 W
4800	5 469 W	10 362 W	13 719 W	14 771 W

Q[W] 55/45/20 °C (ΔT=30 °C)

Length L [mm]	Speed [-] / Heating output [W]			
	1	2	3	4 max.
700	233 W	442 W	586 W	631 W
800	311 W	590 W	780 W	840 W
900	373 W	708 W	937 W	1 009 W
1000	529 W	1 002 W	1 327 W	1 429 W
1100	529 W	1 002 W	1 327 W	1 429 W
1200	623 W	1 179 W	1 561 W	1 681 W
1300	685 W	1 297 W	1 717 W	1 849 W
1400	762 W	1 445 W	1 912 W	2 059 W
1500	840 W	1 592 W	2 108 W	2 269 W
1600	915 W	1 733 W	2 295 W	2 471 W
1700	915 W	1 733 W	2 295 W	2 471 W
1800	1 058 W	2 005 W	2 654 W	2 857 W
1900	1 148 W	2 176 W	2 880 W	3 101 W
2000	1 226 W	2 323 W	3 075 W	3 311 W
2100	1 288 W	2 441 W	3 231 W	3 479 W
2200	1 288 W	2 441 W	3 231 W	3 479 W
2300	1 444 W	2 736 W	3 622 W	3 900 W
2400	1 444 W	2 736 W	3 622 W	3 900 W
2500	1 537 W	2 913 W	3 856 W	4 152 W
2600	1 600 W	3 031 W	4 012 W	4 320 W
2700	1 662 W	3 148 W	4 168 W	4 488 W
2800	1 755 W	3 326 W	4 402 W	4 740 W
2900	1 830 W	3 467 W	4 590 W	4 942 W
3000	1 830 W	3 467 W	4 590 W	4 942 W
3200	2 063 W	3 909 W	5 175 W	5 572 W
3400	2 141 W	4 056 W	5 371 W	5 782 W
3600	2 359 W	4 469 W	5 917 W	6 371 W
3800	2 437 W	4 617 W	6 112 W	6 581 W
4000	2 577 W	4 882 W	6 463 W	6 959 W
4200	2 745 W	5 200 W	6 885 W	7 413 W
4400	2 888 W	5 471 W	7 244 W	7 799 W
4600	3 056 W	5 790 W	7 665 W	8 253 W
4800	3 118 W	5 908 W	7 821 W	8 421 W

75/65/20 °C → 75 °C inlet temperature, 65 °C outlet temp., 20 °C room temp. / **Output 90/70/20 °C** = ~ 1,22 x 75/65/20 °C / **Output 70/55/20 °C** = ~ 0,84 x 75/65/20 °C / Heating outputs in accordance with EN442 / Not listed heating outputs for lengths per 100 mm steps calculate linearly.

Acoustic pressure [dB(A)]

Length L [mm]	Speed [-] / Acoustic pressure [dB(A)]				
	1	2	3	4 max.	
700		26 dB(A)	34 dB(A)	37 dB(A)	
800			35 dB(A)	38 dB(A)	
900		27 dB(A)			
1000			36 dB(A)	39 dB(A)	
1100					
1200	< 20 dB(A)		37 dB(A)	40 dB(A)	
1300					
1400			28 dB(A)		
1500				38 dB(A)	41 dB(A)
1600					
1700		29 dB(A)			
1800			39 dB(A)	42 dB(A)	
1900					
2000	20 dB(A)				
2100		30 dB(A)			
2200			40 dB(A)	43 dB(A)	
2300					
2400	21 dB(A)				
2500		31 dB(A)			
2600			41 dB(A)	44 dB(A)	
2700					
2800	22 dB(A)				
2900		32 dB(A)			
3000			42 dB(A)	45 dB(A)	
3200	23 dB(A)				
3400		33 dB(A)			
3600	24 dB(A)				
3800		34 dB(A)			
4000			43 dB(A)	46 dB(A)	
4200	25 dB(A)				
4400		35 dB(A)			
4600			44 dB(A)	47 dB(A)	
4800	26 dB(A)				

Acoustic pressure level choose according to specific environment. More details on page 10

Fans input power [W]*

Length L [mm]	Speed [-] / Fans input power [W]*			
	1	2	3	4 max.
700	1 W	2 W	2 W	3 W
800	2 W	2 W	3 W	4 W
900	2 W	3 W	4 W	5 W
1000	2 W	3 W	5 W	6 W
1100	2 W	3 W	5 W	6 W
1200	3 W	4 W	6 W	8 W
1300	3 W	5 W	7 W	9 W
1400	3 W	5 W	7 W	9 W
1500	4 W	6 W	8 W	10 W
1600	4 W	6 W	8 W	10 W
1700	4 W	6 W	9 W	11 W
1800	5 W	7 W	10 W	12 W
1900	5 W	7 W	10 W	12 W
2000	5 W	7 W	10 W	13 W
2100	5 W	8 W	11 W	14 W
2200	5 W	8 W	11 W	14 W
2300	6 W	9 W	13 W	16 W
2400	6 W	9 W	13 W	16 W
2500	6 W	9 W	14 W	17 W
2600	7 W	10 W	14 W	18 W
2700	7 W	11 W	15 W	19 W
2800	7 W	11 W	15 W	19 W
2900	7 W	11 W	15 W	19 W
3000	8 W	11 W	16 W	20 W
3200	8 W	12 W	18 W	22 W
3400	9 W	13 W	18 W	23 W
3600	9 W	14 W	20 W	25 W
3800	10 W	14 W	21 W	26 W
4000	11 W	16 W	23 W	28 W
4200	11 W	16 W	23 W	28 W
4400	12 W	17 W	25 W	31 W
4600	12 W	18 W	26 W	32 W
4800	12 W	18 W	27 W	33 W

* Approximate fan input powers / **When using electrothermal actuator add in the trench heater's power 3 W** / Wiring of the trench heater → page 80

FRT 0125 0250

ECO & SAFE | VOLTAGE 24

TRENCH HEATER WITH FAN



- Flats, detached houses, offices, administrative buildings
- Good balance of heating output and size
- High heating output
- Continuous speed control
- Quiet operation
- Common electricity consumption **3 W/m**
- Using in dry environment



Technical data

Trench heater

Height	H = 125 mm
Width	W = 250 mm
Length	L = 700-4 800 mm in step 100 mm

Heat exchanger

Type	Al-Cu lamellar
Length	L-295 mm
Connection thread	2xG1/2" inner

Working conditions

Max. temperature	110 °C
Max. overpressure	1 MPa (10 bar)
Protection	IP 20

Ambient conditions	Temp. T = +2 to +40 °C Humidity Rh = 20 to 70 %
--------------------	--

Variants

Transverse roll-up grilles

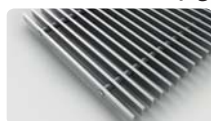

natur - anod. aluminium



bronze - anod. aluminium



black - anod. aluminium

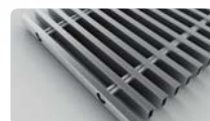

stainless



natur beech - wooden



stained beech - wooden



natur oak - wooden



stained oak - wooden

Linear non-rolling grilles



natur - anod. aluminium



bronze - anod. aluminium



black - anod. aluminium

Peripheral ledges



(more on page 7)

More possibilities and variants → page 6

Trench heater standard equipment

Trough	Galvanized steel trough with surface finish and black spray layer inside, black cover plates of connection
Heat exchanger	Al-Cu lamellar exchanger with air vent valve, black painted
Grille	Design walkable grille according the customer's choice*
Ledge	Made of anodized aluminium, type and colour according the customer's choice
Fan	Modern tangential fan with 24 V DC EC motor with high efficiency, rotors protection
Assembly elements	Leveling screws for setting up the trough, mounting brackets
Manual	Manual for the progress of work during installation and user manual
Wiring	Electrical wiring diagram of the trench heaters
Mounting board	Cover and the spacer particle board for easy installation
Package	Transport package for protection against damage during transportation and handling

*stainless grilles surcharge

Accessories per order

	Room thermostat		Power supply
	Electrothermal actuator		Thermostatic valve
	Lockshield valve		

Accessories details → page 11

Technical drawing

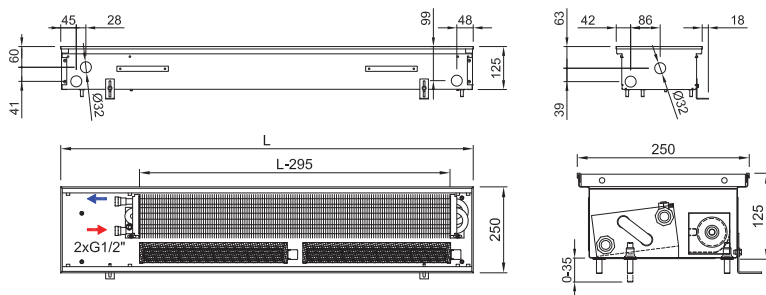

Connection to heating system

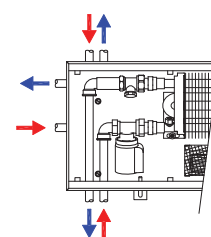

The hydraulic parameters of the heat exchanger → page 78

Code example: FRT 00125 0250 1500 C 62 L2 L - 5

Trench heater **FRT** H = **125** mm, W = **250** mm, L = **1 500** mm, „**C**“ Galvanized steel trough with black inside, heat exchanger and inner parts painted black, „**62**“ stained beech grille, transverse, roll-up „**L2**“ peripheral ledge „**L**“ with an overlap, bronze anodized aluminium, „**L**“ water connection at the left side (when installing the heat exchanger closer to the window, fans to the room) „**5**“ 24 V DC fans without controller (controller is not needed)

 **Trench heater heating output FRT 0125 0250**

Q[W] 75/65/20 °C (ΔT=50 °C)

Temperature exponent 1,1

Length L [mm]	Speed [-] / Heating output [W]			
	1	2	3	4 max.
700	298 W	619 W	822 W	886 W
800	397 W	825 W	1 096 W	1 181 W
900	476 W	990 W	1 315 W	1 417 W
1000	675 W	1 403 W	1 864 W	2 008 W
1100	675 W	1 403 W	1 864 W	2 008 W
1200	794 W	1 651 W	2 192 W	2 362 W
1300	874 W	1 816 W	2 412 W	2 599 W
1400	973 W	2 022 W	2 686 W	2 894 W
1500	1 072 W	2 228 W	2 960 W	3 189 W
1600	1 167 W	2 426 W	3 223 W	3 473 W
1700	1 167 W	2 426 W	3 223 W	3 473 W
1800	1 350 W	2 806 W	3 727 W	4 016 W
1900	1 465 W	3 045 W	4 045 W	4 359 W
2000	1 564 W	3 252 W	4 319 W	4 654 W
2100	1 644 W	3 417 W	4 538 W	4 890 W
2200	1 644 W	3 417 W	4 538 W	4 890 W
2300	1 842 W	3 829 W	5 086 W	5 481 W
2400	1 842 W	3 829 W	5 086 W	5 481 W
2500	1 961 W	4 077 W	5 415 W	5 835 W
2600	2 041 W	4 242 W	5 634 W	6 071 W
2700	2 120 W	4 407 W	5 854 W	6 307 W
2800	2 239 W	4 655 W	6 182 W	6 662 W
2900	2 335 W	4 853 W	6 446 W	6 945 W
3000	2 335 W	4 853 W	6 446 W	6 945 W
3200	2 633 W	5 472 W	7 268 W	7 831 W
3400	2 732 W	5 678 W	7 542 W	8 126 W
3600	3 010 W	6 256 W	8 309 W	8 953 W
3800	3 109 W	6 462 W	8 583 W	9 249 W
4000	3 288 W	6 833 W	9 076 W	9 780 W
4200	3 502 W	7 279 W	9 668 W	10 418 W
4400	3 685 W	7 659 W	10 173 W	10 961 W
4600	3 899 W	8 104 W	10 764 W	11 599 W
4800	3 979 W	8 269 W	10 984 W	11 835 W

75/65/20 °C → 75 °C inlet temperature, 65 °C outlet temp., 20 °C room temp. / **Output 90/70/20 °C** = ~ 1,22 x 75/65/20 °C / **Output 70/55/20 °C** = ~ 0,84 x 75/65/20 °C / Heating outputs in accordance with EN442 / Not listed heating outputs for lengths per 100 mm steps calculate linearly.

Q[W] 55/45/20 °C (ΔT=30 °C)

Length L [mm]	Speed [-] / Heating output [W]			
	1	2	3	4 max.
700	170 W	353 W	469 W	505 W
800	226 W	470 W	625 W	673 W
900	271 W	564 W	750 W	808 W
1000	385 W	800 W	1 063 W	1 145 W
1100	385 W	800 W	1 063 W	1 145 W
1200	453 W	941 W	1 250 W	1 347 W
1300	498 W	1 035 W	1 375 W	1 482 W
1400	555 W	1 153 W	1 531 W	1 650 W
1500	611 W	1 270 W	1 688 W	1 818 W
1600	665 W	1 383 W	1 837 W	1 980 W
1700	665 W	1 383 W	1 837 W	1 980 W
1800	770 W	1 600 W	2 125 W	2 290 W
1900	835 W	1 736 W	2 306 W	2 485 W
2000	892 W	1 854 W	2 462 W	2 653 W
2100	937 W	1 948 W	2 587 W	2 788 W
2200	937 W	1 948 W	2 587 W	2 788 W
2300	1 050 W	2 183 W	2 900 W	3 125 W
2400	1 050 W	2 183 W	2 900 W	3 125 W
2500	1 118 W	2 324 W	3 087 W	3 327 W
2600	1 164 W	2 418 W	3 212 W	3 461 W
2700	1 209 W	2 513 W	3 337 W	3 596 W
2800	1 276 W	2 654 W	3 524 W	3 798 W
2900	1 331 W	2 767 W	3 675 W	3 959 W
3000	1 331 W	2 767 W	3 675 W	3 959 W
3200	1 501 W	3 120 W	4 144 W	4 465 W
3400	1 558 W	3 237 W	4 300 W	4 633 W
3600	1 716 W	3 567 W	4 737 W	5 104 W
3800	1 773 W	3 684 W	4 893 W	5 273 W
4000	1 875 W	3 896 W	5 174 W	5 576 W
4200	1 997 W	4 150 W	5 512 W	5 940 W
4400	2 101 W	4 367 W	5 800 W	6 249 W
4600	2 223 W	4 620 W	6 137 W	6 613 W
4800	2 269 W	4 714 W	6 262 W	6 747 W

 **Acoustic pressure [dB(A)]**

Length L [mm]	Speed [-] / Acoustic pressure [dB(A)]				
	1	2	3	4 max.	
700		26 dB(A)	34 dB(A)	37 dB(A)	
800			35 dB(A)	38 dB(A)	
900		27 dB(A)			
1000			36 dB(A)	39 dB(A)	
1100					
1200	< 20 dB(A)		37 dB(A)	40 dB(A)	
1300					
1400			28 dB(A)		
1500				38 dB(A)	41 dB(A)
1600					
1700			29 dB(A)		
1800			39 dB(A)	42 dB(A)	
1900					
2000	20 dB(A)				
2100		30 dB(A)			
2200			40 dB(A)	43 dB(A)	
2300					
2400	21 dB(A)				
2500		31 dB(A)			
2600			41 dB(A)	44 dB(A)	
2700					
2800	22 dB(A)				
2900		32 dB(A)			
3000			42 dB(A)	45 dB(A)	
3200	23 dB(A)				
3400		33 dB(A)			
3600			43 dB(A)	46 dB(A)	
3800	24 dB(A)				
4000		34 dB(A)			
4200			44 dB(A)	47 dB(A)	
4400	25 dB(A)				
4600		35 dB(A)			
4800	26 dB(A)		44 dB(A)		

Acoustic pressure level choose according to specific environment. More details on page 10

 **Fans input power [W]***

Length L [mm]	Speed [-] / Fans input power [W]*			
	1	2	3	4 max.
700	1 W	2 W	2 W	3 W
800	2 W	2 W	3 W	4 W
900	2 W	3 W	4 W	5 W
1000	2 W	3 W	5 W	6 W
1100	2 W	3 W	5 W	6 W
1200	3 W	4 W	6 W	8 W
1300	3 W	5 W	7 W	9 W
1400	3 W	5 W	7 W	9 W
1500	4 W	6 W	8 W	10 W
1600	4 W	6 W	8 W	10 W
1700	4 W	6 W	9 W	11 W
1800	5 W	7 W	10 W	12 W
1900	5 W	7 W	10 W	12 W
2000	5 W	7 W	10 W	13 W
2100	5 W	8 W	11 W	14 W
2200	5 W	8 W	11 W	14 W
2300	6 W	9 W	13 W	16 W
2400	6 W	9 W	13 W	16 W
2500	6 W	9 W	14 W	17 W
2600	7 W	10 W	14 W	18 W
2700	7 W	11 W	15 W	19 W
2800	7 W	11 W	15 W	19 W
2900	7 W	11 W	15 W	19 W
3000	8 W	11 W	16 W	20 W
3200	8 W	12 W	18 W	22 W
3400	9 W	13 W	18 W	23 W
3600	9 W	14 W	20 W	25 W
3800	10 W	14 W	21 W	26 W
4000	11 W	16 W	23 W	28 W
4200	11 W	16 W	23 W	28 W
4400	12 W	17 W	25 W	31 W
4600	12 W	18 W	26 W	32 W
4800	12 W	18 W	27 W	33 W

* Approximate fan input powers / **When using electrothermal actuator add in the trench heater's power 3 W** / Wiring of the trench heater → page 80

FRT 0125 0300

ECO & SAFE | **VOLTAGE 24**

TRENCH HEATER WITH FAN



- Flats, detached houses, offices, administrative buildings
- Suitable for low-temperature systems
- High heating output
- Continuous speed control
- Quiet operation
- Common electricity consumption **2 W/m**
- Using in dry environment



Technical data

Trench heater

Height	H = 125 mm
Width	W = 300 mm
Length	L = 700-4 800 mm in step 100 mm

Heat exchanger

Type	Al-Cu lamellar
Length	L- 295 mm
Connection thread	2xG1/2" inner

Working conditions

Max. temperature	110 °C
Max. overpressure	1 MPa (10 bar)
Protection	IP 20

Ambient conditions	Temp. T = +2 to +40 °C Humidity Rh = 20 to 70 %
--------------------	--

Variants

Transverse roll-up grilles

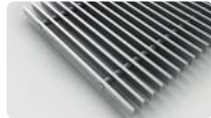

natur - anod. aluminium



bronze - anod. aluminium



black - anod. aluminium

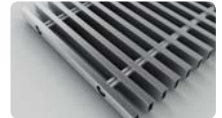

stainless



natur beech - wooden



stained beech - wooden



natur oak - wooden



stained oak - wooden

Linear non-rolling grilles



natur - anod. aluminium



bronze - anod. aluminium



black - anod. aluminium

Peripheral ledges



(more on page 7)

More possibilities and variants → page 6

Trench heater standard equipment

Trough	Galvanized steel trough with surface finish and black spray layer inside, black cover plates of connection
Heat exchanger	Al-Cu lamellar exchanger with air vent valve, black painted
Grille	Design walkable grille according the customer's choice*
Ledge	Made of anodized aluminium, type and colour according the customer's choice
Fan	Modern tangential fan with 24 V DC EC motor with high efficiency, rotors protection
Assembly elements	Leveling screws for setting up the trough, mounting brackets
Manual	Manual for the progress of work during installation and user manual
Wiring	Electrical wiring diagram of the trench heaters
Mounting board	Cover and the spacer particle board for easy installation
Package	Transport package for protection against damage during transportation and handling

*stainless grilles surcharge

Accessories per order

	Room thermostat		Power supply
	Electrothermal actuator		Thermostatic valve
	Lockshield valve		

Accessories details → page 11

Technical drawing

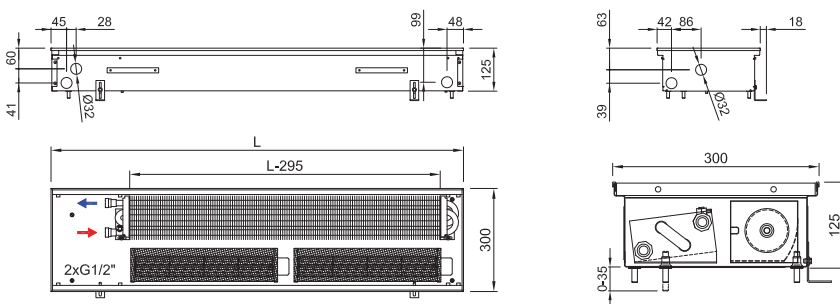

Connection to heating system

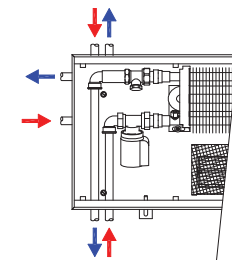

The hydraulic parameters of the heat exchanger → page 78

Code example: FRT 0125 0300 2700 C 32 J3 R - 5

Trench heater **FRT** H=125 mm, W=300 mm, L=2 700 mm, „**C**“ Galvanized steel trough with black inside, heat exchanger and inner parts painted black, „**32**“ black anodized aluminium grille, linear, rigid, „**J3**“ peripheral ledge „**J**“, black anodized aluminium, „**R**“ water connection at the right side (when installing the heat exchanger closer to the window, fans to the room), „**5**“ 24 V DC fans without controller (controller is not needed)

 **Trench heater heating output FRT 0125 0300**

Q[W] 75/65/20 °C (ΔT=50 °C)

Temperature exponent 1,1

Length L [mm]	Speed [-] / Heating output [W]			
	1	2	3	4 max.
700	343 W	664 W	884 W	1 114 W
800	459 W	887 W	1 182 W	1 489 W
900	574 W	1 111 W	1 480 W	1 864 W
1000	751 W	1 453 W	1 935 W	2 438 W
1100	751 W	1 453 W	1 935 W	2 438 W
1200	917 W	1 775 W	2 364 W	2 978 W
1300	1 033 W	1 998 W	2 661 W	3 353 W
1400	1 094 W	2 117 W	2 819 W	3 552 W
1500	1 210 W	2 340 W	3 117 W	3 927 W
1600	1 333 W	2 580 W	3 435 W	4 328 W
1700	1 333 W	2 580 W	3 435 W	4 328 W
1800	1 502 W	2 906 W	3 870 W	4 876 W
1900	1 676 W	3 244 W	4 320 W	5 442 W
2000	1 792 W	3 467 W	4 617 W	5 817 W
2100	1 908 W	3 691 W	4 915 W	6 193 W
2200	1 908 W	3 691 W	4 915 W	6 193 W
2300	2 084 W	4 033 W	5 370 W	6 766 W
2400	2 084 W	4 033 W	5 370 W	6 766 W
2500	2 251 W	4 355 W	5 799 W	7 306 W
2600	2 366 W	4 578 W	6 097 W	7 682 W
2700	2 482 W	4 802 W	6 394 W	8 057 W
2800	2 543 W	4 920 W	6 552 W	8 255 W
2900	2 667 W	5 159 W	6 871 W	8 657 W
3000	2 667 W	5 159 W	6 871 W	8 657 W
3200	3 010 W	5 823 W	7 755 W	9 771 W
3400	3 125 W	6 047 W	8 053 W	10 146 W
3600	3 418 W	6 612 W	8 806 W	11 095 W
3800	3 584 W	6 934 W	9 234 W	11 635 W
4000	3 815 W	7 381 W	9 830 W	12 385 W
4200	4 000 W	7 739 W	10 306 W	12 985 W
4400	4 169 W	8 065 W	10 741 W	13 533 W
4600	4 459 W	8 626 W	11 488 W	14 474 W
4800	4 574 W	8 850 W	11 786 W	14 849 W

75/65/20 °C → 75 °C inlet temperature, 65 °C outlet temp., 20 °C room temp. / **Output 90/70/20 °C** = ~ 1,22 x 75/65/20 °C / **Output 70/55/20 °C** = ~ 0,84 x 75/65/20 °C / Heating outputs in accordance with EN442 / Not listed heating output for lengths per 100 mm steps calculate linearly.

Q[W] 55/45/20 °C (ΔT=30 °C)

Length L [mm]	Speed [-] / Heating output [W]			
	1	2	3	4 max.
700	196 W	379 W	504 W	635 W
800	262 W	506 W	674 W	849 W
900	327 W	633 W	844 W	1 063 W
1000	428 W	828 W	1 103 W	1 390 W
1100	428 W	828 W	1 103 W	1 390 W
1200	523 W	1 012 W	1 348 W	1 698 W
1300	589 W	1 139 W	1 517 W	1 912 W
1400	624 W	1 207 W	1 607 W	2 025 W
1500	690 W	1 334 W	1 777 W	2 239 W
1600	760 W	1 471 W	1 958 W	2 467 W
1700	760 W	1 471 W	1 958 W	2 467 W
1800	856 W	1 657 W	2 206 W	2 780 W
1900	956 W	1 849 W	2 463 W	3 103 W
2000	1 022 W	1 977 W	2 632 W	3 316 W
2100	1 088 W	2 104 W	2 802 W	3 531 W
2200	1 088 W	2 104 W	2 802 W	3 531 W
2300	1 188 W	2 299 W	3 062 W	3 857 W
2400	1 188 W	2 299 W	3 062 W	3 857 W
2500	1 283 W	2 483 W	3 306 W	4 165 W
2600	1 349 W	2 610 W	3 476 W	4 380 W
2700	1 415 W	2 738 W	3 645 W	4 593 W
2800	1 450 W	2 805 W	3 735 W	4 706 W
2900	1 521 W	2 941 W	3 917 W	4 936 W
3000	1 521 W	2 941 W	3 917 W	4 936 W
3200	1 716 W	3 320 W	4 421 W	5 571 W
3400	1 782 W	3 448 W	4 591 W	5 784 W
3600	1 949 W	3 770 W	5 020 W	6 325 W
3800	2 043 W	3 953 W	5 264 W	6 633 W
4000	2 175 W	4 208 W	5 604 W	7 061 W
4200	2 280 W	4 412 W	5 876 W	7 403 W
4400	2 377 W	4 598 W	6 124 W	7 715 W
4600	2 542 W	4 918 W	6 550 W	8 252 W
4800	2 608 W	5 046 W	6 719 W	8 466 W

 **Acoustic pressure [dB(A)]**

Length L [mm]	Speed [-] / Acoustic pressure [dB(A)]			
	1	2	3	4 max.
700	20 dB(A)	26 dB(A)	36 dB(A)	47 dB(A)
800	21 dB(A)	27 dB(A)		37 dB(A)
900				
1000	22 dB(A)	28 dB(A)	38 dB(A)	49 dB(A)
1100				
1200	23 dB(A)	29 dB(A)	39 dB(A)	50 dB(A)
1300				
1400	24 dB(A)	30 dB(A)	40 dB(A)	51 dB(A)
1500				
1600	25 dB(A)	31 dB(A)	41 dB(A)	52 dB(A)
1700				
1800	26 dB(A)	32 dB(A)	42 dB(A)	53 dB(A)
1900				
2000	27 dB(A)	33 dB(A)	43 dB(A)	54 dB(A)
2100				
2200	28 dB(A)	34 dB(A)	44 dB(A)	55 dB(A)
2300				
2400	29 dB(A)	35 dB(A)	45 dB(A)	56 dB(A)
2500				
2600	30 dB(A)	36 dB(A)	46 dB(A)	57 dB(A)
2700				
2800	31 dB(A)	37 dB(A)	47 dB(A)	58 dB(A)
2900				
3000	32 dB(A)	38 dB(A)	48 dB(A)	59 dB(A)
3200				
3400	33 dB(A)	39 dB(A)	49 dB(A)	60 dB(A)
3600				
3800	34 dB(A)	40 dB(A)	50 dB(A)	61 dB(A)
4000				
4200	35 dB(A)	41 dB(A)	51 dB(A)	62 dB(A)
4400				
4600	36 dB(A)	42 dB(A)	52 dB(A)	63 dB(A)
4800				

Acoustic pressure level choose according to specific environment. More details on page 10

 **Fans input power [W]***

Length L [mm]	Speed [-] / Fans input power [W]*			
	1	2	3	4 max.
700	1 W	1 W	3 W	8 W
800	1 W	1 W	4 W	10 W
900	1 W	2 W	6 W	15 W
1000	1 W	2 W	7 W	17 W
1100	1 W	2 W	7 W	17 W
1200	1 W	3 W	8 W	20 W
1300	2 W	3 W	10 W	24 W
1400	2 W	3 W	10 W	24 W
1500	2 W	3 W	11 W	27 W
1600	2 W	4 W	12 W	29 W
1700	2 W	4 W	13 W	32 W
1800	2 W	4 W	14 W	34 W
1900	2 W	5 W	15 W	36 W
2000	2 W	5 W	16 W	39 W
2100	3 W	6 W	18 W	44 W
2200	3 W	6 W	18 W	44 W
2300	3 W	6 W	19 W	46 W
2400	3 W	6 W	19 W	46 W
2500	3 W	6 W	20 W	48 W
2600	3 W	7 W	22 W	53 W
2700	4 W	7 W	24 W	58 W
2800	4 W	7 W	23 W	56 W
2900	4 W	7 W	24 W	58 W
3000	4 W	8 W	24 W	60 W
3200	4 W	8 W	26 W	65 W
3400	4 W	9 W	28 W	68 W
3600	5 W	9 W	30 W	75 W
3800	5 W	10 W	33 W	80 W
4000	5 W	11 W	35 W	87 W
4200	5 W	11 W	35 W	87 W
4400	6 W	12 W	37 W	92 W
4600	6 W	12 W	39 W	96 W
4800	6 W	13 W	41 W	101 W

* Approximate fan input powers / **When using electrothermal actuator add in the trench heater's power 3 W** / Wiring of the trench heater → page 80

FRT 0125 0425

ECO & SAFE | VOLTAGE 24

TRENCH HEATER WITH FAN



- Flats, detached houses, offices, administrative buildings
- Suitable for low-temperature systems
- High heating output
- Continuous speed control
- Quiet operation
- Common electricity consumption **2 W/m**
- Using in dry environment



Technical data

Trench heater

Height	H = 125 mm
Width	W = 425 mm
Length	L = 700-4 800 mm in step 100 mm

Heat exchanger

Type	Al-Cu lamellar
Length	L- 295 mm
Connection thread	2xG1/2" inner

Working conditions

Max. temperature	110 °C
Max. overpressure	1 MPa (10 bar)
Protection	IP 20

Ambient conditions	Temp. T = +2 to +40 °C Humidity Rh = 20 to 70 %
--------------------	--

Variants

Transverse roll-up grilles

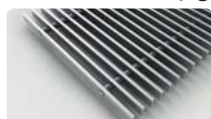

natur - anod. aluminium



bronze - anod. aluminium



black - anod. aluminium

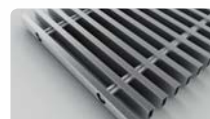

stainless



natur beech - wooden



stained beech - wooden



natur oak - wooden



stained oak - wooden

Linear non-rolling grilles

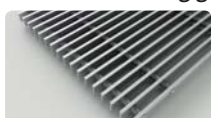

natur - anod. aluminium



bronze - anod. aluminium



black - anod. aluminium

Peripheral ledges



(more on page 7)





More possibilities and variants → page 6

Trench heater standard equipment

Trough	Galvanized steel trough with surface finish and black spray layer inside, black cover plates of connection
Heat exchanger	Al-Cu lamellar exchanger with air vent valve, black painted
Grille	Design walkable grille according the customer's choice*
Ledge	Made of anodized aluminium, type and colour according the customer's choice
Fan	Modern tangential fan with 24 V DC EC motor with high efficiency, rotors protection
Assembly elements	Leveling screws for setting up the trough, mounting brackets
Manual	Manual for the progress of work during installation and user manual
Wiring	Electrical wiring diagram of the trench heaters
Mounting board	Cover and the spacer particle board for easy installation
Package	Transport package for protection against damage during transportation and handling

*stainless grilles surcharge

Accessories per order

	Room thermostat		Power supply
	Electrothermal actuator		Thermostatic valve
	Lockshield valve		

Accessories details → page 11

Technical drawing

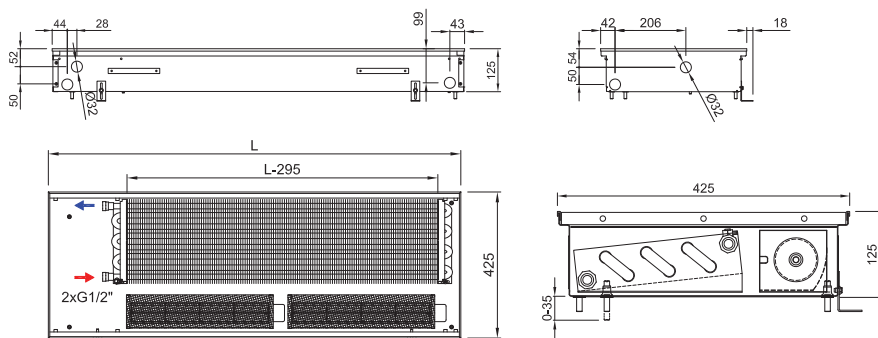

Connection to heating system

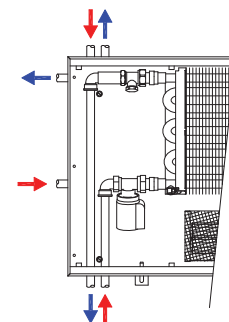

The hydraulic parameters of the heat exchanger → page 78

Code example: FRT 0125 0425 4400 C 64 L2 L - 5

Trench heater FRT H = **125** mm, W = **425** mm, L = **4 400** mm, „C“ Galvanized steel trough with black inside, heat exchanger and inner parts painted black, „64“ stained oak grille, transverse, roll-up, „L2“ peripheral ledge, „L“ with an overlap, bronze anodized aluminium, „L“ water connection at the left side (when installing the heat exchanger closer to the window, fans to the room) „5“ 24 V DC fans without controller (controller is not needed)

Trench heater heating output FRT 0125 0425

Q[W] 75/65/20 °C (ΔT=50 °C)

Temperature exponent 1,1

Length L [mm]	Speed [-] / Heating output [W]			
	1	2	3	4 max.
700	709 W	1 006 W	1 310 W	1 616 W
800	947 W	1 345 W	1 751 W	2 160 W
900	1 186 W	1 684 W	2 192 W	2 704 W
1000	1 551 W	2 202 W	2 867 W	3 536 W
1100	1 551 W	2 202 W	2 867 W	3 536 W
1200	1 895 W	2 690 W	3 502 W	4 320 W
1300	2 133 W	3 029 W	3 943 W	4 864 W
1400	2 260 W	3 209 W	4 177 W	5 152 W
1500	2 498 W	3 548 W	4 618 W	5 696 W
1600	2 754 W	3 910 W	5 090 W	6 279 W
1700	2 754 W	3 910 W	5 090 W	6 279 W
1800	3 102 W	4 405 W	5 734 W	7 073 W
1900	3 463 W	4 916 W	6 400 W	7 894 W
2000	3 701 W	5 255 W	6 841 W	8 438 W
2100	3 940 W	5 594 W	7 282 W	8 983 W
2200	3 940 W	5 594 W	7 282 W	8 983 W
2300	4 305 W	6 113 W	7 956 W	9 815 W
2400	4 305 W	6 113 W	7 956 W	9 815 W
2500	4 649 W	6 600 W	8 592 W	10 598 W
2600	4 887 W	6 939 W	9 033 W	11 142 W
2700	5 126 W	7 278 W	9 474 W	11 687 W
2800	5 252 W	7 458 W	9 707 W	11 975 W
2900	5 508 W	7 820 W	10 179 W	12 557 W
3000	5 508 W	7 820 W	10 179 W	12 557 W
3200	6 216 W	8 827 W	11 489 W	14 173 W
3400	6 455 W	9 165 W	11 930 W	14 717 W
3600	7 059 W	10 023 W	13 046 W	16 093 W
3800	7 402 W	10 511 W	13 681 W	16 877 W
4000	7 880 W	11 188 W	14 563 W	17 965 W
4200	8 261 W	11 730 W	15 269 W	18 836 W
4400	8 610 W	12 225 W	15 913 W	19 630 W
4600	9 209 W	13 076 W	17 020 W	20 995 W
4800	9 447 W	13 414 W	17 461 W	21 540 W

75/65/20 °C → 75 °C inlet temperature, 65 °C outlet temp., 20 °C room temp. / Output 90/70/20 °C ≈ 1,22 x 75/65/20 °C / Output 70/55/20 °C ≈ 0,84 x 75/65/20 °C / Heating outputs in accordance with EN442 / Not listed heating outputs for lengths per 100 mm steps calculate linearly.

Q[W] 55/45/20 °C (ΔT=30 °C)

Length L [mm]	Speed [-] / Heating output [W]			
	1	2	3	4 max.
700	404 W	574 W	747 W	921 W
800	540 W	767 W	998 W	1 231 W
900	676 W	960 W	1 250 W	1 542 W
1000	884 W	1 255 W	1 635 W	2 016 W
1100	884 W	1 255 W	1 635 W	2 016 W
1200	1 080 W	1 534 W	1 997 W	2 463 W
1300	1 216 W	1 727 W	2 248 W	2 773 W
1400	1 288 W	1 830 W	2 381 W	2 937 W
1500	1 424 W	2 023 W	2 633 W	3 247 W
1600	1 570 W	2 229 W	2 902 W	3 580 W
1700	1 570 W	2 229 W	2 902 W	3 580 W
1800	1 769 W	2 511 W	3 269 W	4 032 W
1900	1 974 W	2 803 W	3 649 W	4 501 W
2000	2 110 W	2 996 W	3 900 W	4 811 W
2100	2 246 W	3 189 W	4 152 W	5 121 W
2200	2 246 W	3 189 W	4 152 W	5 121 W
2300	2 454 W	3 485 W	4 536 W	5 596 W
2400	2 454 W	3 485 W	4 536 W	5 596 W
2500	2 650 W	3 763 W	4 898 W	6 042 W
2600	2 786 W	3 956 W	5 150 W	6 352 W
2700	2 922 W	4 149 W	5 401 W	6 663 W
2800	2 994 W	4 252 W	5 534 W	6 827 W
2900	3 140 W	4 458 W	5 803 W	7 159 W
3000	3 140 W	4 458 W	5 803 W	7 159 W
3200	3 544 W	5 032 W	6 550 W	8 080 W
3400	3 680 W	5 225 W	6 802 W	8 390 W
3600	4 024 W	5 714 W	7 438 W	9 175 W
3800	4 220 W	5 993 W	7 800 W	9 622 W
4000	4 493 W	6 379 W	8 303 W	10 242 W
4200	4 710 W	6 688 W	8 705 W	10 739 W
4400	4 909 W	6 970 W	9 072 W	11 191 W
4600	5 250 W	7 455 W	9 703 W	11 970 W
4800	5 386 W	7 648 W	9 955 W	12 280 W

Acoustic pressure [dB(A)]

Length L [mm]	Speed [-] / Acoustic pressure [dB(A)]			
	1	2	3	4 max.
700	20 dB(A)	26 dB(A)	36 dB(A)	47 dB(A)
800	21 dB(A)	27 dB(A)		37 dB(A)
900				
1000	22 dB(A)	28 dB(A)	38 dB(A)	49 dB(A)
1100				
1200	23 dB(A)	29 dB(A)	39 dB(A)	50 dB(A)
1300				
1400	24 dB(A)	30 dB(A)	40 dB(A)	51 dB(A)
1500				
1600	25 dB(A)	31 dB(A)	41 dB(A)	52 dB(A)
1700				
1800	26 dB(A)	32 dB(A)	42 dB(A)	53 dB(A)
1900				
2000	27 dB(A)	33 dB(A)	43 dB(A)	54 dB(A)
2100				
2200	28 dB(A)	34 dB(A)	44 dB(A)	55 dB(A)
2300				
2400	29 dB(A)	35 dB(A)	45 dB(A)	56 dB(A)
2500				
2600	30 dB(A)	36 dB(A)	46 dB(A)	57 dB(A)
2700				
2800	31 dB(A)	37 dB(A)	47 dB(A)	58 dB(A)
2900				
3000	32 dB(A)	38 dB(A)	48 dB(A)	59 dB(A)
3200				
3400	33 dB(A)	39 dB(A)	49 dB(A)	60 dB(A)
3600				
3800	34 dB(A)	40 dB(A)	50 dB(A)	61 dB(A)
4000				
4200	35 dB(A)	41 dB(A)	51 dB(A)	62 dB(A)
4400				
4600	36 dB(A)	42 dB(A)	52 dB(A)	63 dB(A)
4800				

Acoustic pressure level choose according to specific environment. More details on page 10

Fans input power [W]*

Length L [mm]	Speed [-] / Fans input power [W]*			
	1	2	3	4 max.
700	1 W	1 W	3 W	8 W
800	1 W	1 W	4 W	10 W
900	1 W	2 W	6 W	15 W
1000	1 W	2 W	7 W	17 W
1100	1 W	2 W	7 W	17 W
1200	1 W	3 W	8 W	20 W
1300	2 W	3 W	10 W	24 W
1400	2 W	3 W	10 W	24 W
1500	2 W	3 W	11 W	27 W
1600	2 W	4 W	12 W	29 W
1700	2 W	4 W	13 W	32 W
1800	2 W	4 W	14 W	34 W
1900	2 W	5 W	15 W	36 W
2000	2 W	5 W	16 W	39 W
2100	3 W	6 W	18 W	44 W
2200	3 W	6 W	18 W	44 W
2300	3 W	6 W	19 W	46 W
2400	3 W	6 W	19 W	46 W
2500	3 W	6 W	20 W	48 W
2600	3 W	7 W	22 W	53 W
2700	4 W	7 W	24 W	58 W
2800	4 W	7 W	23 W	56 W
2900	4 W	7 W	24 W	58 W
3000	4 W	8 W	24 W	60 W
3200	4 W	8 W	26 W	65 W
3400	4 W	9 W	28 W	68 W
3600	5 W	9 W	30 W	75 W
3800	5 W	10 W	33 W	80 W
4000	5 W	11 W	35 W	87 W
4200	5 W	11 W	35 W	87 W
4400	6 W	12 W	37 W	92 W
4600	6 W	12 W	39 W	96 W
4800	6 W	13 W	41 W	101 W

* Approximate fan input powers / When using electrothermal actuator add in the trench heater's power 3 W / Wiring of the trench heater → page 80

FRT 0140 0250

ECO & SAFE | VOLTAGE 24

TRENCH HEATER WITH FAN



- Flats, detached houses, offices, administrative buildings
- Narrow trench heater suitable for deeper floor
- High heating output
- Continuous speed control
- Quiet operation
- Common electricity consumption **3 W/m**
- Using in dry environment



Technical data

Trench heater

Height	H = 140 mm
Width	W = 250 mm
Length	L = 700-4 800 mm in step 100 mm

Heat exchanger

Type	Al-Cu lamellar
Length	L- 295 mm
Connection thread	2xG1/2" inner

Working conditions

Max. temperature	110 °C
Max. overpressure	1 MPa (10 bar)
Protection	IP 20
Ambient conditions	Temp. T = +2 to +40 °C Humidity Rh = 20 to 70 %

Variants

Transverse roll-up grilles



natur - anod. aluminium



bronze - anod. aluminium



black - anod. aluminium

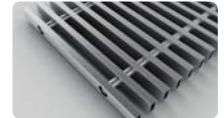

stainless



natur beech - wooden



stained beech - wooden



natur oak - wooden



stained oak - wooden

Linear non-rolling grilles



natur - anod. aluminium



bronze - anod. aluminium



black - anod. aluminium

Peripheral ledges



(more on page 7)

More possibilities and variants → page 6

Trench heater standard equipment

Trough	Galvanized steel trough with surface finish and black spray layer inside, black cover plates of connection
Heat exchanger	Al-Cu lamellar exchanger with air vent valve, black painted
Grille	Design walkable grille according the customer's choice*
Ledge	Made of anodized aluminium, type and colour according the customer's choice
Fan	Modern tangential fan with 24 V DC EC motor with high efficiency, rotors protection
Assembly elements	Leveling screws for setting up the trough, mounting brackets
Manual	Manual for the progress of work during installation and user manual
Wiring	Electrical wiring diagram of the trench heaters
Mounting board	Cover and the spacer particle board for easy installation
Package	Transport package for protection against damage during transportation and handling

*stainless grilles surcharge

Accessories per order

	Room thermostat		Power supply
	Electrothermal actuator		Thermostatic valve
	Lockshield valve		

Accessories details → page 11

Technical drawing

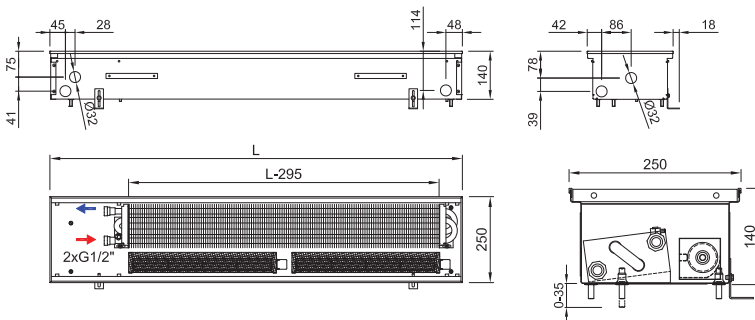

Connection to heating system

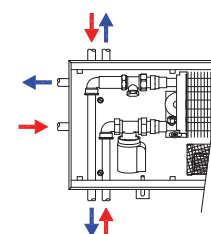

The hydraulic parameters of the heat exchanger → page 78

Code example: FRT 00140 0250 1500 C 62 L2 L - 5

Trench heater FRT H=140 mm, W= 250 mm, L=1 500 mm, „C“ Galvanized steel trough with black inside, heat exchanger and inner parts painted black, „62“ stained beech grille, transverse, roll-up, „L2“ peripheral ledge „L“ with an overlap, bronze anodized aluminium, „L“ water connection at the left side (when installing the heat exchanger closer to the window, fans to the room) „5“ 24 V DC fans without controller (controller is not needed)

 **Trench heater heating output FRT 0140 0250**

Q[W] 75/65/20 °C (ΔT=50 °C)

Temperature exponent 1,1

Length L [mm]	Speed [-] / Heating output [W]			
	1	2	3	4 max.
700	311 W	645 W	894 W	928 W
800	414 W	859 W	1 192 W	1 237 W
900	497 W	1 031 W	1 430 W	1 484 W
1000	704 W	1 461 W	2 026 W	2 103 W
1100	704 W	1 461 W	2 026 W	2 103 W
1200	828 W	1 719 W	2 384 W	2 474 W
1300	911 W	1 891 W	2 622 W	2 722 W
1400	1 015 W	2 106 W	2 920 W	3 031 W
1500	1 118 W	2 320 W	3 218 W	3 340 W
1600	1 218 W	2 527 W	3 504 W	3 637 W
1700	1 218 W	2 527 W	3 504 W	3 637 W
1800	1 408 W	2 922 W	4 053 W	4 206 W
1900	1 528 W	3 171 W	4 398 W	4 565 W
2000	1 632 W	3 386 W	4 696 W	4 874 W
2100	1 714 W	3 558 W	4 935 W	5 121 W
2200	1 714 W	3 558 W	4 935 W	5 121 W
2300	1 922 W	3 988 W	5 531 W	5 740 W
2400	1 922 W	3 988 W	5 531 W	5 740 W
2500	2 046 W	4 245 W	5 888 W	6 111 W
2600	2 129 W	4 417 W	6 127 W	6 358 W
2700	2 211 W	4 589 W	6 365 W	6 606 W
2800	2 336 W	4 847 W	6 723 W	6 977 W
2900	2 435 W	5 053 W	7 009 W	7 274 W
3000	2 435 W	5 053 W	7 009 W	7 274 W
3200	2 746 W	5 698 W	7 903 W	8 202 W
3400	2 849 W	5 913 W	8 201 W	8 511 W
3600	3 139 W	6 514 W	9 035 W	9 377 W
3800	3 243 W	6 729 W	9 333 W	9 686 W
4000	3 429 W	7 116 W	9 869 W	10 243 W
4200	3 653 W	7 580 W	10 513 W	10 911 W
4400	3 843 W	7 975 W	11 061 W	11 480 W
4600	4 067 W	8 439 W	11 705 W	12 148 W
4800	4 149 W	8 611 W	11 943 W	12 395 W

Q[W] 55/45/20 °C (ΔT=30 °C)

Length L [mm]	Speed [-] / Heating output [W]			
	1	2	3	4 max.
700	177 W	368 W	510 W	529 W
800	236 W	490 W	680 W	705 W
900	283 W	588 W	815 W	846 W
1000	401 W	833 W	1 155 W	1 199 W
1100	401 W	833 W	1 155 W	1 199 W
1200	472 W	980 W	1 359 W	1 410 W
1300	519 W	1 078 W	1 495 W	1 552 W
1400	579 W	1 201 W	1 665 W	1 728 W
1500	637 W	1 323 W	1 835 W	1 904 W
1600	694 W	1 441 W	1 998 W	2 074 W
1700	694 W	1 441 W	1 998 W	2 074 W
1800	803 W	1 666 W	2 311 W	2 398 W
1900	871 W	1 808 W	2 507 W	2 603 W
2000	930 W	1 930 W	2 677 W	2 779 W
2100	977 W	2 028 W	2 814 W	2 920 W
2200	977 W	2 028 W	2 814 W	2 920 W
2300	1 096 W	2 274 W	3 153 W	3 272 W
2400	1 096 W	2 274 W	3 153 W	3 272 W
2500	1 166 W	2 420 W	3 357 W	3 484 W
2600	1 214 W	2 518 W	3 493 W	3 625 W
2700	1 261 W	2 616 W	3 629 W	3 766 W
2800	1 332 W	2 763 W	3 833 W	3 978 W
2900	1 388 W	2 881 W	3 996 W	4 147 W
3000	1 388 W	2 881 W	3 996 W	4 147 W
3200	1 566 W	3 249 W	4 506 W	4 676 W
3400	1 624 W	3 371 W	4 676 W	4 852 W
3600	1 790 W	3 714 W	5 151 W	5 346 W
3800	1 849 W	3 836 W	5 321 W	5 522 W
4000	1 955 W	4 057 W	5 627 W	5 840 W
4200	2 083 W	4 322 W	5 994 W	6 221 W
4400	2 191 W	4 547 W	6 306 W	6 545 W
4600	2 319 W	4 811 W	6 673 W	6 926 W
4800	2 365 W	4 909 W	6 809 W	7 067 W

75/65/20 °C → 75 °C inlet temperature, 65 °C outlet temp., 20 °C room temp. / **Output 90/70/20 °C** = ~ 1,22 x 75/65/20 °C / **Output 70/55/20 °C** = ~ 0,84 x 75/65/20 °C / Heating outputs in accordance with EN442 / Not listed heating outputs for lengths per 100 mm steps calculate linearly.

 **Acoustic pressure [dB(A)]**

Length L [mm]	Speed [-] / Acoustic pressure [dB(A)]					
	1	2	3	4 max.		
700	< 20 dB(A)	26 dB(A)	34 dB(A)	37 dB(A)		
800		27 dB(A)	35 dB(A)	38 dB(A)		
900						
1000		28 dB(A)	36 dB(A)	39 dB(A)		
1100						
1200						
1300		29 dB(A)	37 dB(A)	40 dB(A)		
1400						
1500						
1600						
1700	20 dB(A)	38 dB(A)	41 dB(A)			
1800						
1900						
2000						
2100						
2200	21 dB(A)	39 dB(A)	42 dB(A)			
2300						
2400						
2500						
2600						
2700						
2800	22 dB(A)	40 dB(A)	43 dB(A)			
2900						
3000						
3200						
3400						
3600						
3800				23 dB(A)	41 dB(A)	44 dB(A)
4000						
4200						
4400						
4600						
4800						
	24 dB(A)	42 dB(A)	45 dB(A)			
	25 dB(A)	43 dB(A)	46 dB(A)			
	26 dB(A)	44 dB(A)	47 dB(A)			

Acoustic pressure level choose according to specific environment. More details on page 10

 **Fans input power [W]***

Length L [mm]	Speed [-] / Fans input power [W]*			
	1	2	3	4 max.
700	1 W	2 W	2 W	3 W
800	2 W	2 W	3 W	4 W
900	2 W	3 W	4 W	5 W
1000	2 W	3 W	5 W	6 W
1100	2 W	3 W	5 W	6 W
1200	3 W	4 W	6 W	8 W
1300	3 W	5 W	7 W	9 W
1400	3 W	5 W	7 W	9 W
1500	4 W	6 W	8 W	10 W
1600	4 W	6 W	8 W	10 W
1700	4 W	6 W	9 W	11 W
1800	5 W	7 W	10 W	12 W
1900	5 W	7 W	10 W	12 W
2000	5 W	7 W	10 W	13 W
2100	5 W	8 W	11 W	14 W
2200	5 W	8 W	11 W	14 W
2300	6 W	9 W	13 W	16 W
2400	6 W	9 W	13 W	16 W
2500	6 W	9 W	14 W	17 W
2600	7 W	10 W	14 W	18 W
2700	7 W	11 W	15 W	19 W
2800	7 W	11 W	15 W	19 W
2900	7 W	11 W	15 W	19 W
3000	8 W	11 W	16 W	20 W
3200	8 W	12 W	18 W	22 W
3400	9 W	13 W	18 W	23 W
3600	9 W	14 W	20 W	25 W
3800	10 W	14 W	21 W	26 W
4000	11 W	16 W	23 W	28 W
4200	11 W	16 W	23 W	28 W
4400	12 W	17 W	25 W	31 W
4600	12 W	18 W	26 W	32 W
4800	12 W	18 W	27 W	33 W

* Approximate fan input powers / **When using electrothermal actuator add in the trench heater's power 3 W** / Wiring of the trench heater → page 80

FRT 0140 0300

ECO & SAFE | **VOLTAGE 24**

TRENCH HEATER WITH FAN



- Flats, detached houses, offices, administrative buildings
- Suitable for low-temperature systems
- High heating output
- Continuous speed control
- Quiet operation
- Common electricity consumption **2 W/m**
- Using in dry environment



Technical data

Trench heater

Height	H = 140 mm
Width	W = 300 mm
Length	L = 700-4 800 mm in step 100 mm

Heat exchanger

Type	Al-Cu lamellar
Length	L- 295 mm
Connection thread	2xG1/2" inner

Working conditions

Max. temperature	110 °C
Max. overpressure	1 MPa (10 bar)
Protection	IP 20

Ambient conditions	Temp. T = +2 to +40 °C Humidity Rh = 20 to 70 %
--------------------	--

Variants

Transverse roll-up grilles

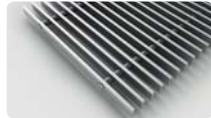

natur - anod. aluminium



bronze - anod. aluminium

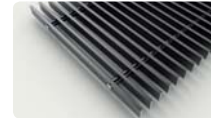

black - anod. aluminium

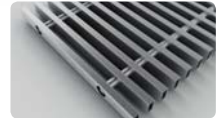

stainless



natur beech - wooden



stained beech - wooden



natur oak - wooden



stained oak - wooden

Linear non-rolling grilles



natur - anod. aluminium



bronze - anod. aluminium



black - anod. aluminium

Peripheral ledges



(more on page 7)

More possibilities and variants → page 6

Trench heater standard equipment

Trough	Galvanized steel trough with surface finish and black spray layer inside, black cover plates of connection
Heat exchanger	Al-Cu lamellar exchanger with air vent valve, black painted
Grille	Design walkable grille according the customer's choice*
Ledge	Made of anodized aluminium, type and colour according the customer's choice
Fan	Modern tangential fan with 24 V DC EC motor with high efficiency, rotors protection
Assembly elements	Leveling screws for setting up the trough, mounting brackets
Manual	Manual for the progress of work during installation and user manual
Wiring	Electrical wiring diagram of the trench heaters
Mounting board	Cover and the spacer particle board for easy installation
Package	Transport package for protection against damage during transportation and handling

*stainless grilles surcharge

Accessories per order

	Room thermostat		Power supply
	Electrothermal actuator		Thermostatic valve
	Lockshield valve		

Accessories details → page 11

Technical drawing

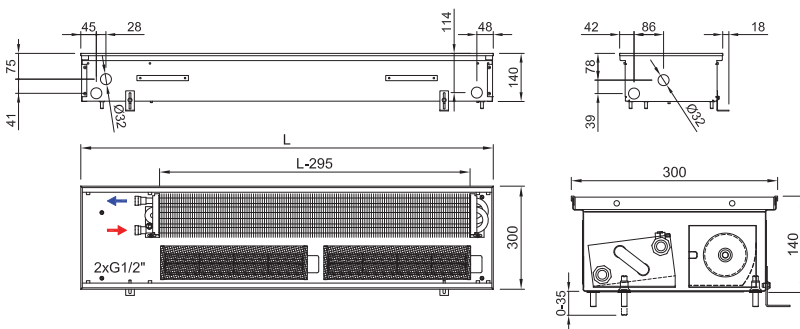

Connection to heating system

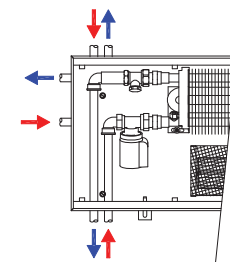

The hydraulic parameters of the heat exchanger → page 78

Code example: FRT 0140 0300 2700 C 32 J3 R - 5

Trench heater FRT H=140 mm, W= 300 mm, L=2 700 mm, „C“ Galvanized steel trough with black inside, heat exchanger and inner parts painted black, „32“ black anodized aluminium grille, linear, rigid, „J3“ peripheral ledge „J“, black anodized aluminium „R“ water connection at the right side (when installing the heat exchanger closer to the window, fans to the room), „5“ 24 V DC fans without controller (controller is not needed)

Trench heater heating output FRT 0140 0300

Q[W] 75/65/20 °C (ΔT=50 °C)

Temperature exponent 1,1

Length L [mm]	Speed [-] / Heating output [W]			
	1	2	3	4 max.
700	446 W	706 W	930 W	1 201 W
800	597 W	944 W	1 244 W	1 605 W
900	747 W	1 182 W	1 557 W	2 009 W
1000	977 W	1 546 W	2 036 W	2 628 W
1100	977 W	1 546 W	2 036 W	2 628 W
1200	1 193 W	1 888 W	2 487 W	3 210 W
1300	1 344 W	2 126 W	2 800 W	3 615 W
1400	1 423 W	2 252 W	2 966 W	3 829 W
1500	1 574 W	2 490 W	3 280 W	4 233 W
1600	1 735 W	2 745 W	3 615 W	4 666 W
1700	1 735 W	2 745 W	3 615 W	4 666 W
1800	1 954 W	3 092 W	4 072 W	5 256 W
1900	2 181 W	3 451 W	4 545 W	5 867 W
2000	2 331 W	3 689 W	4 858 W	6 271 W
2100	2 482 W	3 927 W	5 171 W	6 675 W
2200	2 482 W	3 927 W	5 171 W	6 675 W
2300	2 712 W	4 291 W	5 651 W	7 294 W
2400	2 712 W	4 291 W	5 651 W	7 294 W
2500	2 928 W	4 633 W	6 102 W	7 876 W
2600	3 078 W	4 871 W	6 415 W	8 280 W
2700	3 229 W	5 109 W	6 728 W	8 685 W
2800	3 308 W	5 235 W	6 894 W	8 899 W
2900	3 469 W	5 489 W	7 229 W	9 331 W
3000	3 469 W	5 489 W	7 229 W	9 331 W
3200	3 916 W	6 196 W	8 160 W	10 532 W
3400	4 066 W	6 434 W	8 473 W	10 937 W
3600	4 446 W	7 035 W	9 265 W	11 959 W
3800	4 663 W	7 378 W	9 716 W	12 542 W
4000	4 963 W	7 854 W	10 343 W	13 350 W
4200	5 204 W	8 234 W	10 844 W	13 997 W
4400	5 423 W	8 581 W	11 301 W	14 587 W
4600	5 800 W	9 178 W	12 088 W	15 602 W
4800	5 951 W	9 416 W	12 401 W	16 007 W

75/65/20 °C → 75 °C inlet temperature, 65 °C outlet temp., 20 °C room temp. / Output 90/70/20 °C = ~ 1,22 x 75/65/20 °C / Output 70/55/20 °C = ~ 0,84 x 75/65/20 °C / Heating outputs in accordance with EN442 / Not listed heating outputs for lengths per 100 mm steps calculate linearly.

Q[W] 55/45/20 °C (ΔT=30 °C)

Length L [mm]	Speed [-] / Heating output [W]			
	1	2	3	4 max.
700	254 W	403 W	530 W	685 W
800	340 W	538 W	709 W	915 W
900	426 W	674 W	888 W	1 145 W
1000	557 W	881 W	1 161 W	1 498 W
1100	557 W	881 W	1 161 W	1 498 W
1200	680 W	1 076 W	1 418 W	1 830 W
1300	766 W	1 212 W	1 596 W	2 061 W
1400	811 W	1 284 W	1 691 W	2 183 W
1500	897 W	1 420 W	1 870 W	2 413 W
1600	989 W	1 565 W	2 061 W	2 660 W
1700	989 W	1 565 W	2 061 W	2 660 W
1800	1 114 W	1 763 W	2 322 W	2 997 W
1900	1 243 W	1 967 W	2 591 W	3 345 W
2000	1 329 W	2 103 W	2 770 W	3 575 W
2100	1 415 W	2 239 W	2 948 W	3 806 W
2200	1 415 W	2 239 W	2 948 W	3 806 W
2300	1 546 W	2 446 W	3 222 W	4 158 W
2400	1 546 W	2 446 W	3 222 W	4 158 W
2500	1 669 W	2 641 W	3 479 W	4 490 W
2600	1 755 W	2 777 W	3 657 W	4 721 W
2700	1 841 W	2 913 W	3 836 W	4 951 W
2800	1 886 W	2 985 W	3 930 W	5 073 W
2900	1 978 W	3 129 W	4 121 W	5 320 W
3000	1 978 W	3 129 W	4 121 W	5 320 W
3200	2 233 W	3 532 W	4 652 W	6 005 W
3400	2 318 W	3 668 W	4 831 W	6 235 W
3600	2 535 W	4 011 W	5 282 W	6 818 W
3800	2 658 W	4 206 W	5 539 W	7 150 W
4000	2 830 W	4 478 W	5 897 W	7 611 W
4200	2 967 W	4 694 W	6 182 W	7 980 W
4400	3 092 W	4 892 W	6 443 W	8 316 W
4600	3 307 W	5 233 W	6 892 W	8 895 W
4800	3 393 W	5 368 W	7 070 W	9 126 W

Acoustic pressure [dB(A)]

Length L [mm]	Speed [-] / Acoustic pressure [dB(A)]			
	1	2	3	4 max.
700	20 dB(A)	26 dB(A)	36 dB(A)	47 dB(A)
800	21 dB(A)	27 dB(A)		37 dB(A)
900			22 dB(A)	
1000	23 dB(A)	29 dB(A)		39 dB(A)
1100			24 dB(A)	
1200	25 dB(A)	31 dB(A)		41 dB(A)
1300			26 dB(A)	
1400	27 dB(A)	33 dB(A)		43 dB(A)
1500			28 dB(A)	
1600	29 dB(A)	35 dB(A)		45 dB(A)
1700			30 dB(A)	
1800	31 dB(A)	37 dB(A)		47 dB(A)
1900			32 dB(A)	
2000	33 dB(A)	39 dB(A)		49 dB(A)
2100			34 dB(A)	
2200	35 dB(A)	41 dB(A)		51 dB(A)
2300			36 dB(A)	
2400	37 dB(A)	43 dB(A)		53 dB(A)
2500			38 dB(A)	
2600	39 dB(A)	45 dB(A)		55 dB(A)
2700			40 dB(A)	
2800	41 dB(A)	47 dB(A)		57 dB(A)
2900			42 dB(A)	
3000	43 dB(A)	49 dB(A)		59 dB(A)
3200			44 dB(A)	
3400	45 dB(A)	51 dB(A)		61 dB(A)
3600			46 dB(A)	
3800	47 dB(A)	53 dB(A)		63 dB(A)
4000			48 dB(A)	
4200	49 dB(A)	55 dB(A)		65 dB(A)
4400			50 dB(A)	
4600	51 dB(A)	57 dB(A)		67 dB(A)
4800			52 dB(A)	

Acoustic pressure level choose according to specific environment. More details on page 10

Fans input power [W]*

Length L [mm]	Speed [-] / Fans input power [W]*			
	1	2	3	4 max.
700	1 W	1 W	3 W	8 W
800	1 W	1 W	4 W	10 W
900	1 W	2 W	6 W	15 W
1000	1 W	2 W	7 W	17 W
1100	1 W	2 W	7 W	17 W
1200	1 W	3 W	8 W	20 W
1300	2 W	3 W	10 W	24 W
1400	2 W	3 W	10 W	24 W
1500	2 W	3 W	11 W	27 W
1600	2 W	4 W	12 W	29 W
1700	2 W	4 W	13 W	32 W
1800	2 W	4 W	14 W	34 W
1900	2 W	5 W	15 W	36 W
2000	2 W	5 W	16 W	39 W
2100	3 W	6 W	18 W	44 W
2200	3 W	6 W	18 W	44 W
2300	3 W	6 W	19 W	46 W
2400	3 W	6 W	19 W	46 W
2500	3 W	6 W	20 W	48 W
2600	3 W	7 W	22 W	53 W
2700	4 W	7 W	24 W	58 W
2800	4 W	7 W	23 W	56 W
2900	4 W	7 W	24 W	58 W
3000	4 W	8 W	24 W	60 W
3200	4 W	8 W	26 W	65 W
3400	4 W	9 W	28 W	68 W
3600	5 W	9 W	30 W	75 W
3800	5 W	10 W	33 W	80 W
4000	5 W	11 W	35 W	87 W
4200	5 W	11 W	35 W	87 W
4400	6 W	12 W	37 W	92 W
4600	6 W	12 W	39 W	96 W
4800	6 W	13 W	41 W	101 W

* Approximate fan input powers / When using electrothermal actuator add in the trench heater's power 3 W / Wiring of the trench heater → page 80

FRT 0140 0425

TRENCH HEATER WITH FAN

ECO & SAFE | VOLTAGE 24



- Flats, detached houses, offices, administrative buildings
- Suitable for low-temperature systems
- High heating output
- Continuous speed control
- Quiet operation
- Common electricity consumption **2 W/m**
- Using in dry environment

Technical data

Trench heater

Height	H = 140 mm
Width	W = 425 mm
Length	L = 700-4 800 mm in step 100 mm

Heat exchanger

Type	Al-Cu lamellar
Length	L- 295 mm
Connection thread	2xG1/2" inner

Working conditions

Max. temperature	110 °C
Max. overpressure	1 MPa (10 bar)
Protection	IP 20

Ambient conditions	Temp. T = +2 to +40 °C Humidity Rh = 20 to 70 %
--------------------	--

Variants

Transverse roll-up grilles

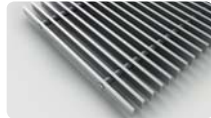

natur - anod. aluminium



bronze - anod. aluminium



black - anod. aluminium

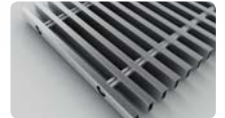

stainless



natur beech - wooden



stained beech - wooden



natur oak - wooden



stained oak - wooden

Linear non-rolling grilles



natur - anod. aluminium



bronze - anod. aluminium



black - anod. aluminium

Peripheral ledges



(more on page 7)

More possibilities and variants → page 6

Trench heater standard equipment

Trough	Galvanized steel trough with surface finish and black spray layer inside, black cover plates of connection
Heat exchanger	Al-Cu lamellar exchanger with air vent valve, black painted
Grille	Design walkable grille according the customer's choice*
Ledge	Made of anodized aluminium, type and colour according the customer's choice
Fan	Modern tangential fan with 24 V DC EC motor with high efficiency, rotors protection
Assembly elements	Leveling screws for setting up the trough, mounting brackets
Manual	Manual for the progress of work during installation and user manual
Wiring	Electrical wiring diagram of the trench heaters
Mounting board	Cover and the spacer particle board for easy installation
Package	Transport package for protection against damage during transportation and handling

*stainless grilles surcharge

Accessories per order

	Room thermostat		Power supply
	Electrothermal actuator		Thermostatic valve
	Lockshield valve		

Accessories details → page 11

Technical drawing

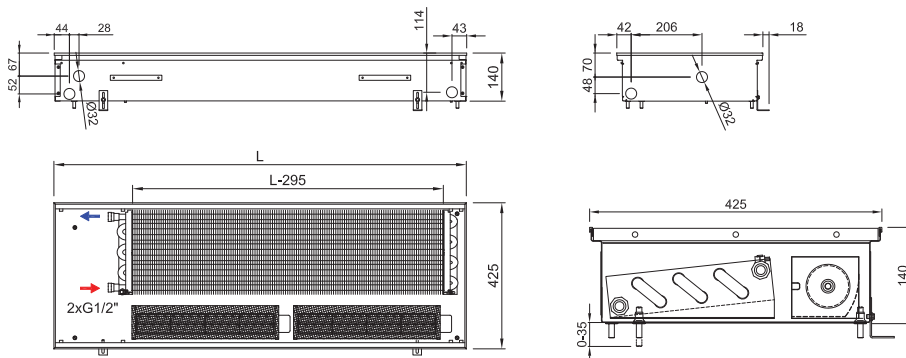

Connection to heating system

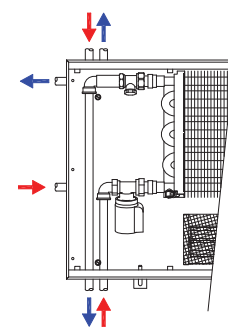

The hydraulic parameters of the heat exchanger → page 78

Code example: FRT 0140 0425 4400 C 64 L2 L - 5

Trench heater FRT H = **140** mm, W = **425** mm, L = **4 400** mm, „C“ Galvanized steel trough with black inside, heat exchanger and inner parts painted black, „64“ stained oak grille, transverse, roll-up, „L2“ peripheral ledge, „L“ with an overlap, bronze anodized aluminium, „L“ water connection at the left side (when installing the heat exchanger closer to the window, fans to the room) „5“ 24 V DC fans without controller (controller is not needed)

 **Trench heater heating output FRT 0140 0425**

Q[W] 75/65/20 °C (ΔT=50 °C)

Temperature exponent 1,1

Length L [mm]	Speed [-] / Heating output [W]			
	1	2	3	4 max.
700	757 W	1 046 W	1 373 W	1 726 W
800	1 012 W	1 399 W	1 835 W	2 307 W
900	1 267 W	1 751 W	2 297 W	2 888 W
1000	1 657 W	2 290 W	3 004 W	3 777 W
1100	1 657 W	2 290 W	3 004 W	3 777 W
1200	2 024 W	2 797 W	3 670 W	4 614 W
1300	2 279 W	3 150 W	4 132 W	5 195 W
1400	2 414 W	3 336 W	4 377 W	5 503 W
1500	2 669 W	3 689 W	4 839 W	6 084 W
1600	2 942 W	4 066 W	5 333 W	6 706 W
1700	2 942 W	4 066 W	5 333 W	6 706 W
1800	3 314 W	4 580 W	6 008 W	7 554 W
1900	3 699 W	5 112 W	6 706 W	8 432 W
2000	3 954 W	5 464 W	7 168 W	9 013 W
2100	4 209 W	5 817 W	7 630 W	9 594 W
2200	4 209 W	5 817 W	7 630 W	9 594 W
2300	4 599 W	6 356 W	8 338 W	10 483 W
2400	4 599 W	6 356 W	8 338 W	10 483 W
2500	4 966 W	6 863 W	9 003 W	11 320 W
2600	5 221 W	7 215 W	9 465 W	11 901 W
2700	5 476 W	7 568 W	9 927 W	12 482 W
2800	5 611 W	7 754 W	10 172 W	12 790 W
2900	5 884 W	8 131 W	10 667 W	13 411 W
3000	5 884 W	8 131 W	10 667 W	13 411 W
3200	6 641 W	9 178 W	12 040 W	15 137 W
3400	6 896 W	9 530 W	12 502 W	15 718 W
3600	7 541 W	10 421 W	13 671 W	17 189 W
3800	7 908 W	10 929 W	14 337 W	18 025 W
4000	8 418 W	11 633 W	15 261 W	19 187 W
4200	8 826 W	12 197 W	16 000 W	20 117 W
4400	9 198 W	12 711 W	16 675 W	20 966 W
4600	9 838 W	13 596 W	17 835 W	22 424 W
4800	10 093 W	13 948 W	18 297 W	23 005 W

75/65/20 °C → 75 °C inlet temperature, 65 °C outlet temp., 20 °C room temp. / **Output 90/70/20 °C** = ~ 1,22 x 75/65/20 °C / **Output 70/55/20 °C** = ~ 0,84 x 75/65/20 °C / Heating outputs in accordance with EN442 / Not listed heating outputs for lengths per 100 mm steps calculate linearly.

Q[W] 55/45/20 °C (ΔT=30 °C)

Length L [mm]	Speed [-] / Heating output [W]			
	1	2	3	4 max.
700	432 W	596 W	783 W	984 W
800	577 W	798 W	1 046 W	1 315 W
900	722 W	998 W	1 310 W	1 647 W
1000	945 W	1 306 W	1 713 W	2 153 W
1100	945 W	1 306 W	1 713 W	2 153 W
1200	1 154 W	1 595 W	2 092 W	2 631 W
1300	1 299 W	1 796 W	2 356 W	2 962 W
1400	1 376 W	1 902 W	2 495 W	3 137 W
1500	1 522 W	2 103 W	2 759 W	3 469 W
1600	1 677 W	2 318 W	3 040 W	3 823 W
1700	1 677 W	2 318 W	3 040 W	3 823 W
1800	1 889 W	2 611 W	3 425 W	4 307 W
1900	2 109 W	2 914 W	3 823 W	4 807 W
2000	2 254 W	3 115 W	4 087 W	5 138 W
2100	2 400 W	3 316 W	4 350 W	5 470 W
2200	2 400 W	3 316 W	4 350 W	5 470 W
2300	2 622 W	3 624 W	4 754 W	5 977 W
2400	2 622 W	3 624 W	4 754 W	5 977 W
2500	2 831 W	3 913 W	5 133 W	6 454 W
2600	2 977 W	4 113 W	5 396 W	6 785 W
2700	3 122 W	4 315 W	5 660 W	7 116 W
2800	3 199 W	4 421 W	5 799 W	7 292 W
2900	3 355 W	4 636 W	6 081 W	7 646 W
3000	3 355 W	4 636 W	6 081 W	7 646 W
3200	3 786 W	5 233 W	6 864 W	8 630 W
3400	3 932 W	5 433 W	7 128 W	8 961 W
3600	4 299 W	5 941 W	7 794 W	9 800 W
3800	4 509 W	6 231 W	8 174 W	10 276 W
4000	4 799 W	6 632 W	8 701 W	10 939 W
4200	5 032 W	6 954 W	9 122 W	11 469 W
4400	5 244 W	7 247 W	9 507 W	11 953 W
4600	5 609 W	7 751 W	10 168 W	12 784 W
4800	5 754 W	7 952 W	10 431 W	13 116 W

 **Acoustic pressure [dB(A)]**

Length L [mm]	Speed [-] / Acoustic pressure [dB(A)]			
	1	2	3	4 max.
700	20 dB(A)	26 dB(A)	36 dB(A)	47 dB(A)
800	21 dB(A)	27 dB(A)		37 dB(A)
900				
1000	22 dB(A)	28 dB(A)	38 dB(A)	49 dB(A)
1100				
1200	23 dB(A)	29 dB(A)	39 dB(A)	50 dB(A)
1300				
1400	24 dB(A)	30 dB(A)	40 dB(A)	51 dB(A)
1500				
1600	25 dB(A)	31 dB(A)	41 dB(A)	52 dB(A)
1700				
1800	26 dB(A)	32 dB(A)	42 dB(A)	53 dB(A)
1900				
2000	27 dB(A)	33 dB(A)	43 dB(A)	54 dB(A)
2100				
2200	28 dB(A)	34 dB(A)	44 dB(A)	55 dB(A)
2300				
2400	29 dB(A)	35 dB(A)	45 dB(A)	56 dB(A)
2500				
2600	30 dB(A)	36 dB(A)	46 dB(A)	57 dB(A)
2700				
2800	31 dB(A)	37 dB(A)	47 dB(A)	58 dB(A)
2900				
3000	32 dB(A)	38 dB(A)	48 dB(A)	59 dB(A)
3200				
3400	33 dB(A)	39 dB(A)	49 dB(A)	60 dB(A)
3600				
3800	34 dB(A)	40 dB(A)	50 dB(A)	61 dB(A)
4000				
4200	35 dB(A)	41 dB(A)	51 dB(A)	62 dB(A)
4400				
4600	36 dB(A)	42 dB(A)	52 dB(A)	63 dB(A)
4800				

Acoustic pressure level choose according to specific environment. More details on page 10

 **Fans input power [W]***

Length L [mm]	Speed [-] / Fans input power [W]*			
	1	2	3	4 max.
700	1 W	1 W	3 W	8 W
800	1 W	1 W	4 W	10 W
900	1 W	2 W	6 W	15 W
1000	1 W	2 W	7 W	17 W
1100	1 W	2 W	7 W	17 W
1200	1 W	3 W	8 W	20 W
1300	2 W	3 W	10 W	24 W
1400	2 W	3 W	10 W	24 W
1500	2 W	3 W	11 W	27 W
1600	2 W	4 W	12 W	29 W
1700	2 W	4 W	13 W	32 W
1800	2 W	4 W	14 W	34 W
1900	2 W	5 W	15 W	36 W
2000	2 W	5 W	16 W	39 W
2100	3 W	6 W	18 W	44 W
2200	3 W	6 W	18 W	44 W
2300	3 W	6 W	19 W	46 W
2400	3 W	6 W	19 W	46 W
2500	3 W	6 W	20 W	48 W
2600	3 W	7 W	22 W	53 W
2700	4 W	7 W	24 W	58 W
2800	4 W	7 W	23 W	56 W
2900	4 W	7 W	24 W	58 W
3000	4 W	8 W	24 W	60 W
3200	4 W	8 W	26 W	65 W
3400	4 W	9 W	28 W	68 W
3600	5 W	9 W	30 W	75 W
3800	5 W	10 W	33 W	80 W
4000	5 W	11 W	35 W	87 W
4200	5 W	11 W	35 W	87 W
4400	6 W	12 W	37 W	92 W
4600	6 W	12 W	39 W	96 W
4800	6 W	13 W	41 W	101 W

* Approximate fan input powers / **When using electrothermal actuator add in the trench heater's power 3 W** / Wiring of the trench heater → page 80

New Practic - FRK



trench heaters with natural convection

FRK trench heaters with natural convection are installed under glazing covering the entire area of buildings. Trench heaters form a thermal barrier to keep the flow of cold air from the window surface. A part of warm air is directed inwards and heats residential spaces. The trench heaters are normally used as additional heating combined with other types of heating. If the heat output of the trench heater is sufficient the trench heater may also be used as the main heating system. These trench heaters are also suitable to adjust temperatures in entrance halls, commercial areas and long corridors.

A great range of the heights and widths of the trench heaters gives the designer many options how to fit the model with the required output in the configuration of the floor. Necessary data are presented in data sheets for individual products.

The range of FRK models with natural convection

Height	80 mm	90 mm	110 mm	125 mm	140 mm	165 mm	200 mm
Width	-	175 mm	175 mm	175 mm	175 mm	-	-
	-	200 mm	200 mm	200 mm	200 mm	-	-
	250 mm	250 mm	250 mm	250 mm	250 mm	-	-
	300 mm	300 mm	300 mm	300 mm	300 mm	300 mm	300 mm
	-	425 mm	425 mm	425 mm	425 mm	425 mm	425 mm

Trench heater „made to measure“

Based on the requirements of larger projects it is possible to supply a “made to measure” trench heater with adjusted height and width. Having approved the structure we will submit a protocol from a test room presenting output parameters. We also offer modifications of the trench heater for the use in humid environment, the connection of air handling piping and others. The technical documentation is first consulted with the customer and only then the production of the trench heater starts.

Working conditions

- Installation in a hot water heating system with forced circulation
- Maximal operating temperature of heating medium 110 °C
- Maximal operating overpressure 1 MPa
- Ambient temperature +2 to +40 °C
- Relative humidity of environment 20 to 70%

Placement in the floor

The trench heaters are laid in the floor so that the exchanger is closer to the window side. The vertical and horizontal distribution of temperatures in the heated room is uniform and conditions are created to provide thermal comfort. Air flow is comparable to the heat transfer with classical heating bodies placed on the wall below windows.

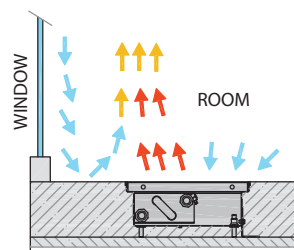

Connecting the heating system

The lamellar Al-Cu heat exchangers have aluminium lamellas pressed onto a copper pipe. The heating medium flows through this pipe. The inlet and outlet of the pipe is provided with a connecting end with internal thread G1/2". Normally the water connection of the heat exchanger is on the left side (when the heat exchanger is placed nearer the window).

We install a thermostatic valve fitted with an electrothermal actuator on the inlet of the lamellar heat exchanger. The actuator works in the opened/closed mode and controls the flow of the heating medium.

The second option is to use a mechanical thermostat with a capillary. The regulation is proportional, no electric power is necessary. However each trench heater shall be fitted with its own thermostat with a capillary. Suitable for single long heating bodies.

It is not necessary to use a thermostatic valve if the temperature of the heating medium is controlled by the heating system (e.g. equithermal system). The way of regulation is to be determined by the designer of the heating and this shall be specified in the project documentation.

A return regulating screw connection shall be used for the outlet. This enables the incorporation of the trench heater into the heating system from the viewpoint of the hydraulic balancing. Based on the parameters of the screw connection used the designer determines the setting (corresponding to pressure loss at the fitting) and this value shall be specified in the project documentation.

Each exchanger is fitted with an air vent valve. When the heating system is connected and filled air bubbles remain caught in the upper part of the exchanger. These shall be let out through the air vent valve.

Connection with an electrothermal actuator

Connection of the electrothermal actuator 24 V DC

The thermostat opens and closes the flow of heating medium through the heat exchanger in dependence on temperature changes in the room. The flow is controlled with an electrothermal actuator 24 V DC. The connection will be used if there is the requirement for safe voltage of 24 V DC in the trench heater or if the trench heaters are combined with the FRT ventilator in a single room. In such case the trench heater is connected to a shared thermostat. Regulation takes place in the opened/closed mode (ON/OFF).

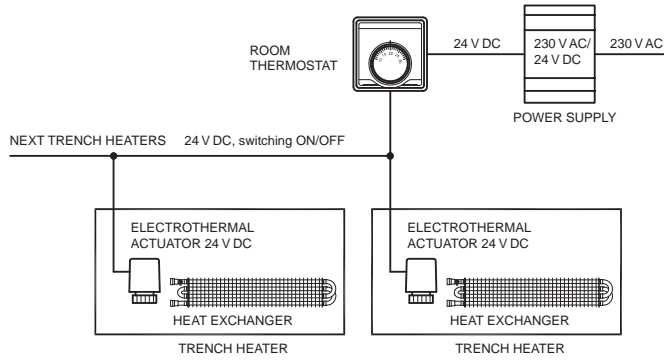

Connection of the electrothermal actuator 230 V AC

Simplified connection using the voltage of 230 V AC for trench heaters with natural convection FRK. Simple cabling, a thermal actuator with IP54 protection. Regulation takes place in the opened/closed mode (ON/OFF).

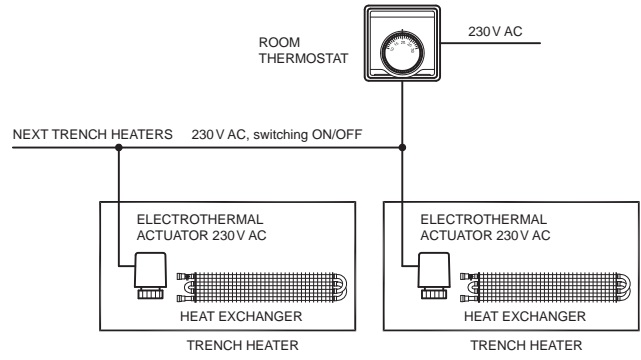

Connection with the capillary thermostat

The capillary thermostat automatically maintains a preset temperature in the room. The temperature is regulated in dependence on the user's requirements without the need for other energy sources. Maintaining the preset temperature is secured by air flowing around the thermal sensor. The thermostatic valve will release only such amount of water into the heating body that is needed to maintain the set temperature in the room. The capillary thermostat is installed to each trench heater.

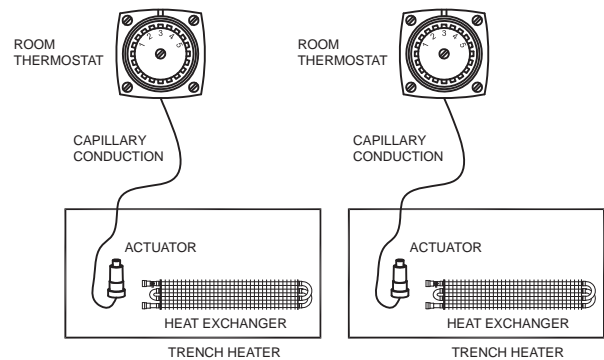

The output of the trench heater

The tables contain output data for thermal gradient 75/65/20°C, standardized output according to standard ČSN EN 442-2. This standard also defines the procedure for conversion to other thermal gradients. The second table presents a converted thermal gradient of 55/45/20°C and a fast approximate conversion for gradients of 90/70/20°C and 70/55/20°C.

Hydraulics

The table with hydraulic resistance is presented on page 78.

Warranty conditions

The Seller's warranty covers joint tightness, surface treatment, proclaimed values of heating capacity and loss in pressure relating to heating bodies professionally installed in a closed and sealed system in accordance with applicable standards and decrees, this all under the aspect that the used medium must only serve as the heat carrier. Other usage is excluded. Electric heating bodies shall be professionally installed in accordance with the applicable standards. FRT trench heaters with fans, IP 20 – dry environs.

Periods of risk

The period of risk is 5 years for joint tightness, 10 years for exchanger and 2 years for electro-installation and stainless steel trough.

FRK - accessories

Controls and possibly a power supply need to be added to trench heaters to secure their correct function. The temperature in the room is assessed by a special thermostat (Z-RT001, Z-TF001), which controls the flow of heating medium through the exchanger. The thermostat Z-RT001 controls the flow via an electrothermal actuator (Z-TS24, Z-TS230), which opens or closes a thermostatic valve (Z-TD001, Z-TE001) in the opened/closed mode. The thermostat Z-TF001 controls the thermostatic valve continuously without the need to connect it to a power supply. We install the thermostatic valve at the inlet into the exchanger. In order to adjust the flow of the heating medium it is necessary to install and set a lockshield valve (Z-RD001, Z-RE001) at the exchanger's outlet. The entire circuit functions on the basis of safe voltage of 24 V DC, which is provided by a switched power supply 24 V DC (DR, DRP). This type of connection will especially be used in rooms with the combination of trench heaters with a fan and trench heaters without a fan – this all is connected to thermostat RTD201. The second option is the connection of Z-TS230 without the use of a power source – only for rooms with trench heaters without fans.

Z-RT001

ROOM THERMOSTAT for flow control in trench heaters without fan

The mechanical room thermostat Z-RT001. In dependence on required temperature it controls the flow of heating medium in the heat exchanger in trench heaters with natural convection. It controls electrothermal actuators Z-TS24 with a switched power supply 24 V DC (DR). Without the power supply it directly controls the electrothermal actuator Z-TS230 working with the voltage of 230 V AC. Function opened/closed.

Parameters

- Temperature range: 10 to 30 °C
- Operating voltage: 24 V DC or 230 V AC
- The number of controlled electrothermal actuators:
24 V DC - 10×Z-TS24
230 V AC - 30×Z-TS230
- Protection: IP30
- Colour: white
- Dimension: 83×83×40 mm



Z-TF001

ROOM THERMOSTAT with a thermostatic head with a capillary

For the flow control in trench heaters without fan FRK

The thermostatic head Z-TF001 with remote control with a liquid sensor is meant for the control of thermostatic valves of FRK trench heaters. The temperature is regulated in dependence on the user's requirements without the need for other energy sources. Each trench heater must have its own Z-TF001, more trench heaters cannot be controlled!

Parameters

- Thermostatic radiator valve head with remote liquid-filled sensing element
- Temperature range: 9 to 26 °C, antifreeze temperature 9°C
- Mode: proportional control
- Operating temperature: without additional energy, liquid-filled sensing
- Capillara tube length: 5 m
- Body-head connection: M30×1,5 mm
- Dimension: 75×75 mm, sensor ø 50×68 mm
- Colour: white to RAL 9010



Z-TS24/Z-TS24-5m

ELECTROTHERMAL ACTUATOR 24 V DC / opened/closed function (without voltage closed)

Parameters

- Input voltage: 24 V DC
- Power consumption: at switch-on 6 VA, input at operation: 2,5 W
- Opening/closing time: 270 s
- Degree of protection: IP54 cover of the casing
- Connection to valve: M30×1,5 mm
- Total height at max. lift: 74 mm
- Colour of actuator and cabel: black RAL9005

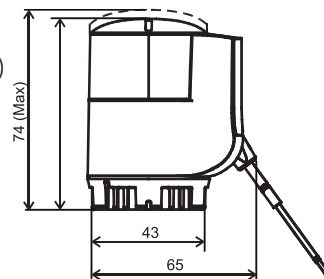

Z-TS24 cable length 3 m
Z-TS24-5m cable length 5 m

Z-TS230/Z-TS230-5m

ELECTROTHERMAL ACTUATOR 230 V AC / opened/closed function (without voltage closed)

Parameters

- Input voltage: 230 V AC
- Power consumption: at switch-on 58 VA, input at operation: 2,5 W
- Opening/closing time: 210 s
- Degree of protection: IP54 cover of the casing
- Connection to valve: M30×1,5 mm
- Total height at max. lift: 74 mm
- Colour of actuator and cabel: black RAL9005

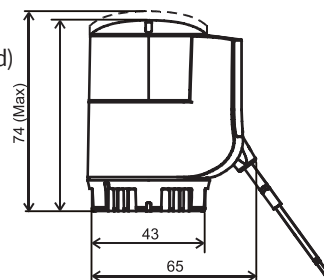

Z-TS230 cable length 3 m
Z-TS230-5m cable length 5 m

DR60-24 / DR100-24

POWER SUPPLY

It converts the voltage from 230 V AC mains to safe voltage of 24 V DC, sources with the preparation for installation on the DIN bar.



DR60-24, 60 W
24 V DC, 78×93×56 mm



DR100-24, 100 W
24 V DC, 100×93×56 mm

Description

- For the placement of the source provide sufficient space in the switchboard
- DR60-24 a DR100-24 may be installed in a box for wall installation
- Size the output to fit the input of installed bodies and cabling, provide 5% output reserve on the source against calculated consumption

KP10

BOX FOR POWER SUPPLY

Box to place under plaster, for the installation of the power supply

Parameters

- Option of installation of DR60-24 and DR100-24
- Attachment to DIN bar
- Installation under plaster
- 234×176×79 mm
- For the case when more supplies need to be installed
- When the space in the switchboard is not sufficient



Z-TD001 / Z-TE001

THERMOSTATIC VALVE DIRECT AND CORNER

Direct and corner thermostatic valve, heating medium flow regulation in the system, installation on the heat exchanger's inlet pipe direct/corner.

Parameters

- Size: DN15, NF standard
- Connecting thread: M30×1,5 mm
- Max. operating temperature 120 °C
- Max. operating pressure PN10
- Option to change pre-setting of kv-value
- kv value (m³/h) range 0.10-0.89
- kv value (m³/h) for zone 2K 0.52

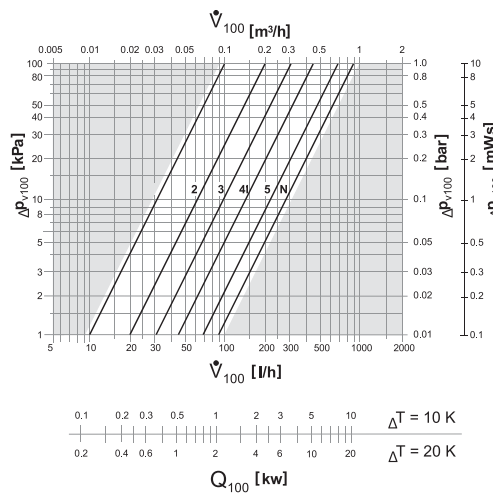

Z-TD001
direct thermostatic valve



Z-TE001
corner thermostatic valve

Z-RD001 / Z-RE001

LOCKSHIELD VALVE DIRECT AND CORNER

Direct and corner closing and regulation screw connection, flow setting, installation on the exchanger's outlet pipe.

Parameters

- Size: DN15
- Value kvs
- direct 0.30-1.80
- corner 0.30-3.00
- Max. operating temperature: 110 °C
- Max. operating overpressure: 10 bar



Z-RD001
direct screw connection



Z-RE001
corner screw connection

Kv (°) T – Speed	0,5	0,75	1	1,5	2	2,5	3	3,5	4	5	6	Max.
Kv (m ³ /h) – direct type	0,3	0,4	0,55	0,75	0,91	1,05	1,25	1,33	1,4	1,6	1,7	1,8
Kv (m ³ /h) – corner type	0,2	0,25	0,29	0,4	0,5	0,69	0,8	1	1,2	1,55	1,9	2,2

PR40, PR50

EXTENSION PIECES WITH ELBOWS

For easy connection of the trench heater to the heating system in the direction towards the room centre. The length of the extension piece and the types of elbows will set the connection points opposite the openings in the trench heater's trough.

PR50 extension piece 50 mm, 2×elbow 90°

- Use for models
- FRK 0080 0250
 - FRK 0080 0300
 - FRK 0090 0250
 - FRK 0090 0300
 - FRK 0090 0425

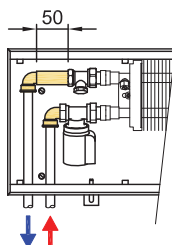

PR40 – extension piece 40 mm, 2×elbow 90°

All other models FRK, except for the ones stated with PR50

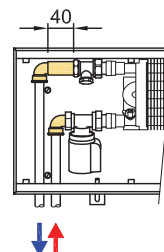

2x



1x

FRK 0080 0250/0300

TRENCH HEATERS WITH NATURAL CONVECTION



- Offices, corridors, halls, flats, winter garden
- High heating output of natural convection
- Suitable for combining with other heating systems
- Using in dry environment
- 2pipe system



Technical data

Trench heater

Height	H = 80 mm
Width	W = 250, 300 mm
Length	L = 700-4 800 mm in step 100 mm

Heat exchanger

Type	Al-Cu lamellar
Length	L-295 mm
Connection thread	2xG1/2" inner

Working conditions

Max. temperature	110 °C
Max. overpressure	1 MPa (10 bar)
Protection	IP 20

Ambient conditions	Temp. T = +2 to +40 °C Humidity Rh = 20 to 70%
--------------------	---

Variants

Transverse roll-up grilles

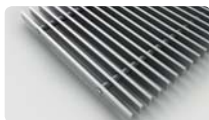

natur - anod. aluminium



bronze - anod. aluminium



black - anod. aluminium



stainless



natur beech - wooden



stained beech - wooden



natur oak - wooden



stained oak - wooden

Linear non-rolling grilles



natur - anod. aluminium



bronze - anod. aluminium



black - anod. aluminium

Peripheral ledges



(more on page 7)

More possibilities and variants → page 6



Trench heater heating output FRK 0080 0250/0300

Q[W] 75/65/20 °C (ΔT=50 °C)

HxW [mm]	0080 0250	0080 0300
L [mm]	n=1,369	n=1,376
700	115 W	119 W
800	144 W	148 W
900	172 W	177 W
1000	200 W	206 W
1100	229 W	236 W
1200	257 W	265 W
1300	286 W	294 W
1400	314 W	324 W
1500	343 W	353 W
1600	371 W	382 W
1700	399 W	411 W
1800	428 W	441 W
1900	456 W	470 W
2000	485 W	499 W
2100	513 W	528 W
2200	542 W	558 W
2300	570 W	587 W
2400	598 W	616 W
2500	627 W	646 W
2600	655 W	675 W
2700	684 W	704 W
2800	712 W	733 W
2900	741 W	763 W
3000	769 W	792 W
3200	826 W	850 W
3400	883 W	909 W
3600	940 W	968 W
3800	996 W	1026 W
4000	1053 W	1085 W
4200	1110 W	1143 W
4400	1167 W	1202 W
4600	1224 W	1260 W
4800	1281 W	1319 W

Q[W] 55/45/20 °C (ΔT=30 °C)

HxW [mm]	0080 0250	0080 0300
L [mm]	n=1,369	n=1,376
700	57 W	59 W
800	72 W	73 W
900	85 W	88 W
1000	99 W	102 W
1100	114 W	117 W
1200	128 W	131 W
1300	142 W	146 W
1400	156 W	160 W
1500	170 W	175 W
1600	184 W	189 W
1700	198 W	204 W
1800	213 W	218 W
1900	227 W	233 W
2000	241 W	247 W
2100	255 W	262 W
2200	269 W	276 W
2300	283 W	291 W
2400	297 W	305 W
2500	312 W	320 W
2600	326 W	334 W
2700	340 W	349 W
2800	354 W	363 W
2900	368 W	378 W
3000	382 W	392 W
3200	410 W	421 W
3400	439 W	450 W
3600	467 W	479 W
3800	495 W	508 W
4000	523 W	537 W
4200	552 W	566 W
4400	580 W	595 W
4600	608 W	624 W
4800	637 W	653 W

75/65/20 °C → 75 °C inlet temperature, 65 °C outlet temp., 20 °C room temp. / Output 90/70/20 °C = ~ 1,29 x 75/65/20 °C / Output 70/55/20 °C = ~ 0,80 x 75/65/20 °C / Heating outputs in accordance with EN442 / Not listed heating outputs for lengths per 100 mm steps calculate linearly.



Technical drawing

FRK 0080 0250

FRK 0080 0300

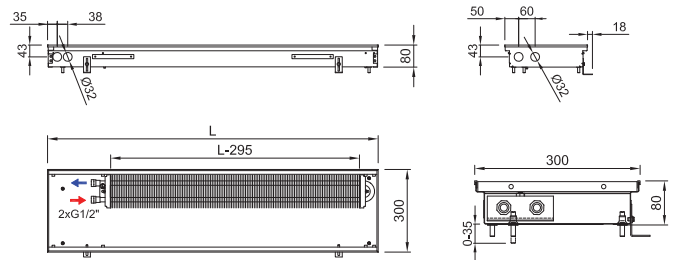
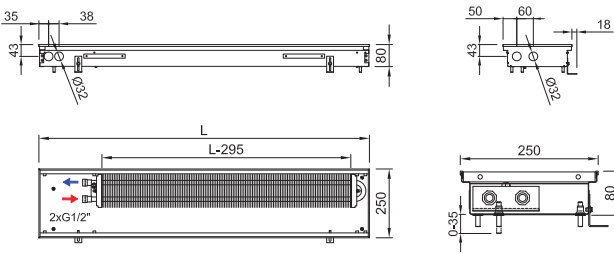

Connection to heating system

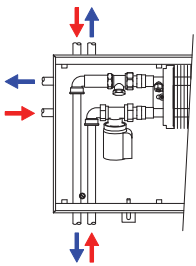







The hydraulic parameters of the heat exchanger → page 78

Trench heater standard equipment

Trough	Galvanized steel trough with surface finish and black spray layer inside, black cover plates of connection
Heat exchanger	Al-Cu lamellar exchanger with air vent valve, black painted
Grille	Design walkable grille according to the customer's choice*
Ledge	Made of anodized aluminium, type and colour according to the customer's choice
Assembly elements	Leveling screws for setting up the trough, mounting brackets
Manual	Manual for the progress of work during installation and user manual
Wiring	Electrical wiring diagram of the trench heaters
Mounting board	Cover and the spacer particle board for easy installation
Package	Transport package for protection against damage during transportation and handling

*stainless grilles surcharge

Accessories per order

	Manual thermostat		Room thermostat with a capillary
	Electrothermal actuator		Power supply
	Lockshield valve		Thermostatic valve

Accessories details → page 60

Code example: FRK 0080 0250 1900 C 11 L1 L - 0

Trench heater **FRK** H=80 mm, W= 250 mm, L=1 900 mm, „C“ Galvanized steel trough with black inside, heat exchanger and inner parts painted black, „15“, Low natural anodized aluminium grille, transverse, rigid, „L1“ peripheral ledge „L“ with an overlap, natur anodized aluminium „L“ water connection at the left side (when installing the heat exchanger closer to the window, fans to the room), „0“ trench heater with natural convection

FRK 0090 0175/0200/0250/0300/0425

TRENCH HEATERS WITH NATURAL CONVECTION



- Offices, corridors, halls, flats, winter garden
- High heating output of natural convection
- Suitable for combining with other heating systems
- Using in dry environment
- 2pipe system



FRK 0090 0175

Technical data

Trench heater

Height	H = 90 mm
Width	W = 175, 200, 250, 300, 425 mm
Length	L = 700-4 800 mm in step 100 mm

Heat exchanger

Type	Al-Cu lamellar
Length	L-295 mm
Connection thread	2xG1/2" inner

Working conditions

Max. temperature	110 °C
Max. overpressure	1 MPa (10 bar)
Protection	IP 20

Ambient conditions	Temp. T = +2 to +40 °C Humidity Rh = 20 to 70%
--------------------	---

Variants

Transverse roll-up grilles

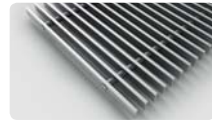

natur - anod. aluminium



bronze - anod. aluminium



black - anod. aluminium

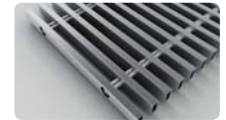

stainless



natur beech - wooden



stained beech - wooden



natur oak - wooden



stained oak - wooden

Linear non-rolling grilles



natur - anod. aluminium



bronze - anod. aluminium



black - anod. aluminium



(more on page 7)

More possibilities and variants → page 6

FRK Trench heater heating output FRK 0090 0175/0200/0250/0300/0425

Q[W] 75/65/20 °C (ΔT=50 °C)

HxW [mm]	0090 0175	0090 0200	0090 0250	0090 0300	0090 0425
L [mm]	n=1,46	n=1,463	n=1,375	n=1,369	n=1,389
700	79 W	94 W	137 W	146 W	209 W
800	98 W	117 W	171 W	182 W	261 W
900	118 W	140 W	205 W	218 W	313 W
1000	137 W	164 W	239 W	254 W	365 W
1100	157 W	187 W	273 W	290 W	416 W
1200	176 W	210 W	306 W	326 W	468 W
1300	196 W	233 W	340 W	362 W	520 W
1400	215 W	256 W	374 W	398 W	572 W
1500	235 W	279 W	408 W	434 W	623 W
1600	254 W	303 W	442 W	470 W	675 W
1700	274 W	326 W	476 W	506 W	727 W
1800	293 W	349 W	510 W	542 W	778 W
1900	313 W	372 W	544 W	578 W	830 W
2000	332 W	395 W	577 W	614 W	882 W
2100	352 W	419 W	611 W	650 W	934 W
2200	371 W	442 W	645 W	686 W	985 W
2300	391 W	465 W	679 W	722 W	1037 W
2400	411 W	488 W	713 W	758 W	1089 W
2500	430 W	511 W	747 W	794 W	1140 W
2600	450 W	535 W	781 W	830 W	1192 W
2700	469 W	558 W	814 W	866 W	1244 W
2800	489 W	581 W	848 W	902 W	1296 W
2900	508 W	604 W	882 W	938 W	1347 W
3000	528 W	627 W	916 W	974 W	1399 W
3200	567 W	674 W	984 W	1046 W	1502 W
3400	606 W	720 W	1052 W	1118 W	1606 W
3600	645 W	766 W	1119 W	1190 W	1709 W
3800	684 W	813 W	1187 W	1262 W	1813 W
4000	723 W	859 W	1255 W	1334 W	1916 W
4200	762 W	906 W	1322 W	1406 W	2020 W
4400	801 W	952 W	1390 W	1478 W	2123 W
4600	840 W	998 W	1458 W	1550 W	2227 W
4800	879 W	1045 W	1526 W	1622 W	2330 W

Q[W] 55/45/20 °C (ΔT=30 °C)

HxW [mm]	0090 0175	0090 0200	0090 0250	0090 0300	0090 0425
L [mm]	n=1,46	n=1,463	n=1,375	n=1,369	n=1,389
700	37 W	45 W	68 W	73 W	103 W
800	46 W	55 W	85 W	90 W	128 W
900	56 W	66 W	102 W	108 W	154 W
1000	65 W	78 W	118 W	126 W	180 W
1100	74 W	89 W	135 W	144 W	205 W
1200	83 W	99 W	152 W	162 W	230 W
1300	93 W	110 W	168 W	180 W	256 W
1400	102 W	121 W	185 W	198 W	281 W
1500	111 W	132 W	202 W	216 W	306 W
1600	120 W	144 W	219 W	234 W	332 W
1700	130 W	154 W	236 W	251 W	358 W
1800	139 W	165 W	253 W	269 W	383 W
1900	148 W	176 W	270 W	287 W	408 W
2000	157 W	187 W	286 W	305 W	434 W
2100	167 W	198 W	303 W	323 W	459 W
2200	176 W	209 W	320 W	341 W	484 W
2300	185 W	220 W	336 W	359 W	510 W
2400	195 W	231 W	353 W	377 W	536 W
2500	204 W	242 W	370 W	395 W	561 W
2600	213 W	253 W	387 W	412 W	586 W
2700	222 W	264 W	403 W	430 W	612 W
2800	232 W	275 W	420 W	448 W	637 W
2900	241 W	286 W	437 W	466 W	662 W
3000	250 W	297 W	454 W	484 W	688 W
3200	269 W	319 W	488 W	520 W	739 W
3400	287 W	341 W	521 W	556 W	790 W
3600	306 W	363 W	554 W	591 W	841 W
3800	324 W	385 W	588 W	627 W	892 W
4000	343 W	407 W	622 W	663 W	942 W
4200	361 W	429 W	655 W	699 W	993 W
4400	380 W	451 W	689 W	734 W	1 044 W
4600	398 W	473 W	722 W	770 W	1 095 W
4800	417 W	495 W	756 W	806 W	1 146 W

75/65/20 °C → 75 °C inlet temperature, 65 °C outlet temp., 20 °C room temp. / Output 90/70/20 °C = ~ 1,29 x 75/65/20 °C / Output 70/55/20 °C = ~ 0,80 x 75/65/20 °C / Heating outputs in accordance with EN442 / Not listed heating outputs for lengths per 100 mm steps calculate linearly.



Technical drawing

FRK 0090 0175

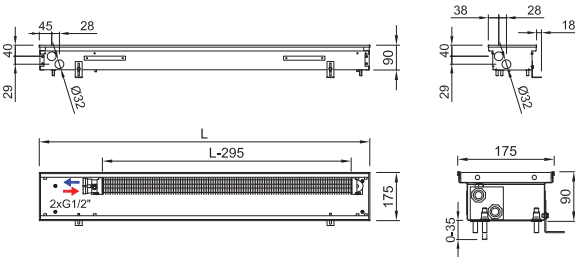

FRK 0090 0200

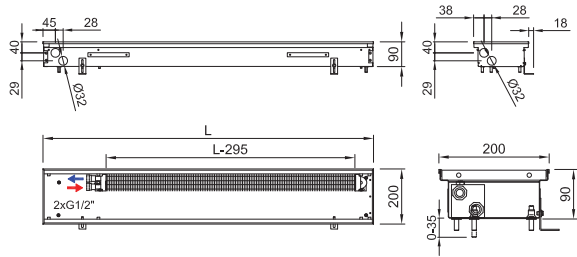

FRK 0090 0250

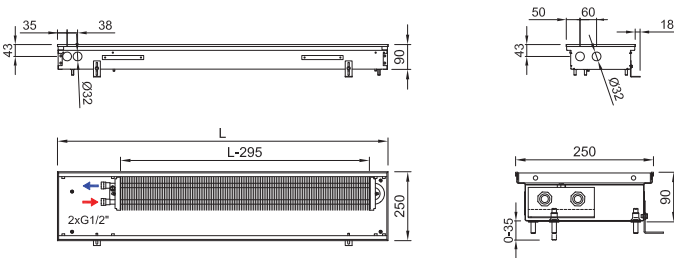

FRK 0090 0300

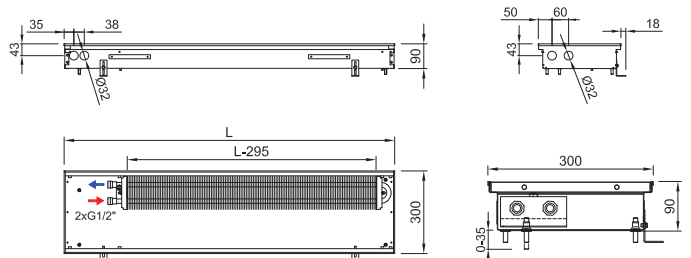

Connection to heating system

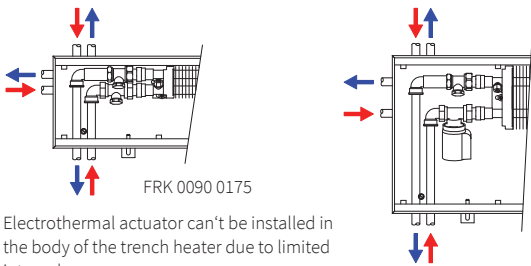

FRK 0090 0175
Electrothermal actuator can't be installed in the body of the trench heater due to limited internal space.

The hydraulic parameters of the heat exchanger → page 78

FRK 0090 0425

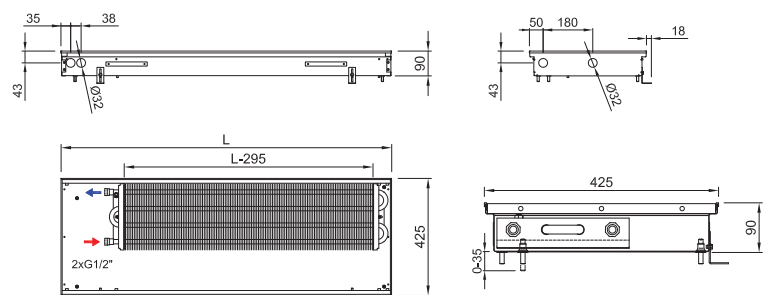

Trench heater standard equipment

Trough	Galvanized steel trough with surface finish and black spray layer inside, black cover plates of connection
Heat exchanger	Al-Cu lamellar exchanger with air vent valve, black painted
Grille	Design walkable grille according the customer's choice*
Ledge	Made of anodized aluminium, type and colour according the customer's choice
Assembly elements	Leveling screws for setting up the trough, mounting brackets
Manual	Manual for the progress of work during installation and user manual
Wiring	Electrical wiring diagram of the trench heaters
Mounting board	Cover and the spacer particle board for easy installation
Package	Transport package for protection against damage during transportation and handling

*stainless grilles surcharge

Accessories per order

	Manual hermostat		Room thermostat with a capillary
	Electrothermal actuator		Power supply
	Lockshield valve		Thermostatic valve

Accessories details → page 60

Code example: FRK 0090 0300 0900 C 12 J1 L - 0

Trench heater FRK H=90 mm, W= 300 mm, L=900 mm, „C“ Galvanized steel trough with black inside, heat exchanger and inner parts painted black, „12“ natur anodized aluminium grille, linear, rigid „J1“ peripheral ledge „J“, natur anodized aluminium, „L“ water connection at the left side (when installing the heat exchanger closer to the window, fans to the room), „0“ trench heater with natural convection

FRK 0110 0175/0200/0250/0300/0425

TRENCH HEATERS WITH NATURAL CONVECTION



- Offices, corridors, halls, flats, winter garden
- High heating output of natural convection
- Suitable for combining with other heating systems
- Using in dry environment
- 2pipe system



FRK 0110 0175

Technical data

Trench heater

Height	H = 110 mm
Width	W = 175, 200, 250, 300, 425 mm
Length	L = 700-4 800 mm in step 100 mm

Heat exchanger

Type	Al-Cu lamellar
Length	L- 295 mm
Connection thread	2×G1/2" inner

Working conditions

Max. temperature	110 °C
Max. overpressure	1 MPa (10 bar)
Protection	IP 20

Ambient conditions	Temp. T = +2 to +40 °C Humidity Rh = 20 to 70 %
--------------------	--

Variants

Transverse roll-up grilles

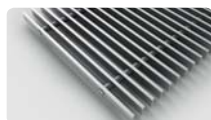

natur - anod. aluminium



bronze - anod. aluminium



black - anod. aluminium

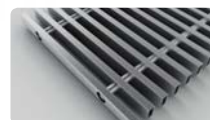

stainless



natur beech - wooden



stained beech - wooden



natur oak - wooden



stained oak - wooden

Linear non-rolling grilles



natur - anod. aluminium



bronze - anod. aluminium



black - anod. aluminium



(more on page 7)

More possibilities and variants → page 6

FRK Trench heater heating output FRK 0110 0175/0200/0250/0300/0425

Q[W] 75/65/20 °C (ΔT=50 °C)

H×W [mm]	0110 0175	0110 0200	0110 0250	0110 0300	0110 0425
L [mm]	n=1,479	n=1,479	n=1,46	n=1,468	n=1,403
700	103 W	110 W	166 W	182 W	245 W
800	129 W	137 W	207 W	227 W	305 W
900	155 W	164 W	248 W	272 W	365 W
1000	180 W	191 W	289 W	316 W	425 W
1100	206 W	218 W	330 W	361 W	486 W
1200	232 W	246 W	371 W	406 W	546 W
1300	257 W	273 W	413 W	451 W	607 W
1400	283 W	300 W	454 W	496 W	667 W
1500	308 W	327 W	495 W	541 W	727 W
1600	334 W	354 W	536 W	586 W	788 W
1700	359 W	381 W	577 W	631 W	848 W
1800	385 W	408 W	618 W	676 W	908 W
1900	411 W	435 W	659 W	720 W	969 W
2000	436 W	463 W	700 W	765 W	1 029 W
2100	462 W	490 W	741 W	810 W	1 089 W
2200	487 W	517 W	782 W	855 W	1 150 W
2300	513 W	544 W	823 W	900 W	1 210 W
2400	539 W	571 W	864 W	945 W	1 270 W
2500	564 W	598 W	905 W	990 W	1 331 W
2600	590 W	625 W	946 W	1 035 W	1 391 W
2700	615 W	653 W	987 W	1 080 W	1 451 W
2800	641 W	680 W	1 028 W	1 124 W	1 512 W
2900	667 W	707 W	1 069 W	1 169 W	1 572 W
3000	692 W	734 W	1 110 W	1 214 W	1 632 W
3200	743 W	788 W	1 192 W	1 304 W	1 753 W
3400	794 W	842 W	1 275 W	1 394 W	1 874 W
3600	846 W	897 W	1 357 W	1 484 W	1 995 W
3800	897 W	951 W	1 439 W	1 573 W	2 115 W
4000	948 W	1 005 W	1 521 W	1 663 W	2 236 W
4200	999 W	1 060 W	1 603 W	1 753 W	2 357 W
4400	1 050 W	1 114 W	1 685 W	1 843 W	2 477 W
4600	1 101 W	1 168 W	1 767 W	1 932 W	2 598 W
4800	1 153 W	1 222 W	1 849 W	2 022 W	2 719 W

Q[W] 55/45/20 °C (ΔT=30 °C)

H×W [mm]	0110 0175	0110 0200	0110 0250	0110 0300	0110 0425
L [mm]	n=1,479	n=1,479	n=1,46	n=1,468	n=1,403
700	48 W	52 W	79 W	86 W	120 W
800	61 W	64 W	98 W	107 W	149 W
900	73 W	77 W	118 W	129 W	178 W
1000	85 W	90 W	137 W	149 W	208 W
1100	97 W	102 W	157 W	171 W	237 W
1200	109 W	116 W	176 W	192 W	267 W
1300	121 W	128 W	196 W	213 W	297 W
1400	133 W	141 W	215 W	234 W	326 W
1500	145 W	154 W	235 W	256 W	355 W
1600	157 W	166 W	254 W	277 W	385 W
1700	169 W	179 W	274 W	298 W	414 W
1800	181 W	192 W	293 W	319 W	444 W
1900	193 W	204 W	313 W	340 W	473 W
2000	205 W	217 W	332 W	361 W	503 W
2100	217 W	230 W	351 W	383 W	532 W
2200	229 W	243 W	371 W	404 W	562 W
2300	241 W	256 W	390 W	425 W	591 W
2400	253 W	268 W	410 W	446 W	620 W
2500	265 W	281 W	429 W	468 W	650 W
2600	277 W	294 W	449 W	489 W	679 W
2700	289 W	307 W	468 W	510 W	709 W
2800	301 W	319 W	488 W	531 W	739 W
2900	313 W	332 W	507 W	552 W	768 W
3000	325 W	345 W	526 W	574 W	797 W
3200	349 W	370 W	565 W	616 W	856 W
3400	373 W	395 W	605 W	659 W	915 W
3600	398 W	421 W	644 W	701 W	975 W
3800	421 W	447 W	683 W	743 W	1 033 W
4000	445 W	472 W	721 W	786 W	1 092 W
4200	469 W	498 W	760 W	828 W	1 151 W
4400	493 W	523 W	799 W	871 W	1 210 W
4600	517 W	549 W	838 W	913 W	1 269 W
4800	542 W	574 W	877 W	955 W	1 328 W

75/65/20 °C → 75 °C inlet temperature, 65 °C outlet temp., 20 °C room temp. / Output 90/70/20 °C = ~ 1,29 x 75/65/20 °C / Output 70/55/20 °C = ~ 0,80 x 75/65/20 °C / Heating outputs in accordance with EN442 / Not listed heating output for lengths per 100 mm steps calculate linearly.



Technical drawing

FRK 0110 0175

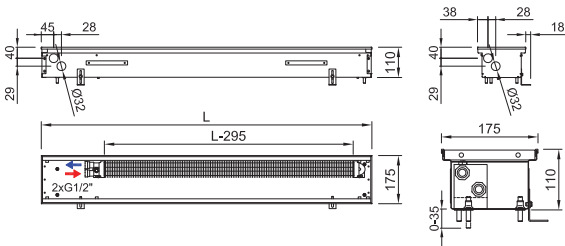

FRK 0110 0200

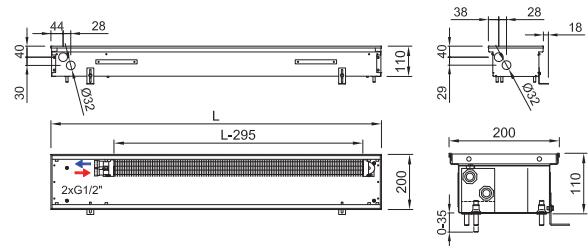

FRK 0110 0250

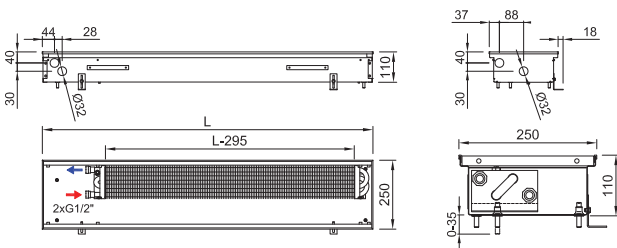

FRK 0110 0300

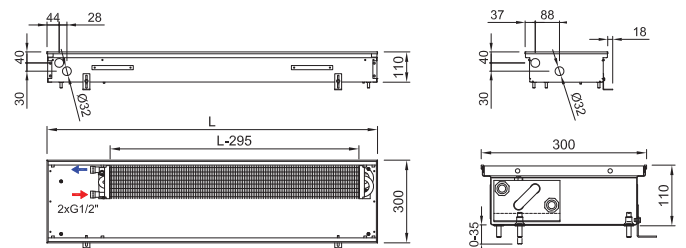

Connection to heating system

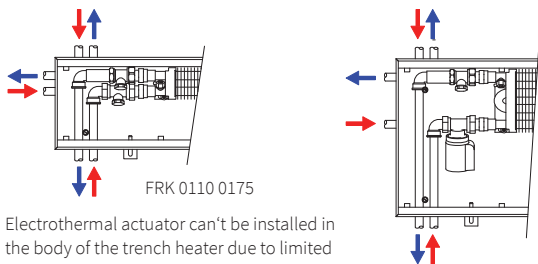

Electrothermal actuator can't be installed in the body of the trench heater due to limited internal space.

The hydraulic parameters of the heat exchanger → page 78

FRK 0110 0425

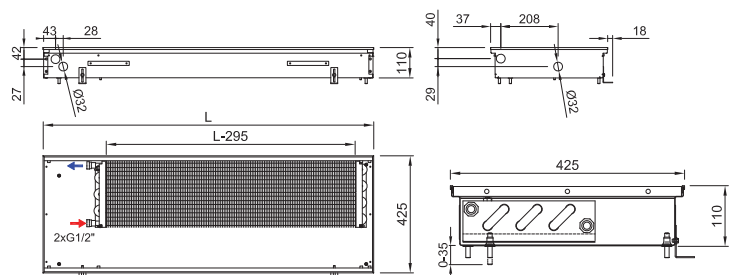

Trench heater standard equipment

- Trough** Galvanized steel trough with surface finish and black spray layer inside, black cover plates of connection
- Heat exchanger** Al-Cu lamellar exchanger with air vent valve, black painted
- Grille** Design walkable grille according the customer's choice*
- Ledge** Made of anodized aluminium, type and colour according the customer's choice
- Assembly elements** Leveling screws for setting up the trough, mounting brackets
- Manual** Manual for the progress of work during installation and user manual
- Wiring** Electrical wiring diagram of the trench heaters
- Mounting board** Cover and the spacer particle board for easy installation
- Package** Transport package for protection against damage during transportation and handling

*stainless grilles surcharge

Accessories per order

- Manual thermostat
- Room thermostat with a capillary
- Electrothermal actuator
- Power supply
- Lockshield valve
- Thermostatic valve

Accessories details → page 60

Code example: FRK 0110 0175 2200 C 21 J2 R - 0

Trench heater **FRK** H=110 mm, W=175 mm, L=2 200 mm, „**C**“ Galvanized steel trough with black inside, heat exchanger and inner parts painted black, „**21**“ bronze anodized aluminium grille, transverse, roll-up, „**J2**“ peripheral ledge „**J**“, bronze anodized aluminium, „**R**“ water connection at the right side (when installing the heat exchanger closer to the window, fans to the room), „**0**“ trench heater with natural convection

FRK 0125 0175/0200/0250/0300/0425

TRENCH HEATERS WITH NATURAL CONVECTION



- Offices, corridors, halls, flats, winter garden
- High heating output of natural convection
- Suitable for combining with other heating systems
- Using in dry environment
- 2pipe system

Technical data

Trench heater

Height	H = 125 mm
Width	W = 175, 200, 250, 300, 425 mm
Length	L = 700-4 800 mm in step 100 mm

Heat exchanger

Type	Al-Cu lamellar
Length	L- 295 mm
Connection thread	2×G1/2" inner

Working conditions

Max. temperature	110 °C
Max. overpressure	1 MPa (10 bar)
Protection	IP 20

Ambient conditions	Temp. T = +2 to +40 °C Humidity Rh = 20 to 70 %
--------------------	--



FRK 0125 0175

Variants

Transverse roll-up grilles

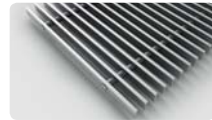

natur - anod. aluminium



bronze - anod. aluminium

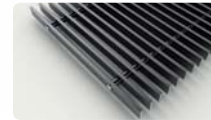

black - anod. aluminium

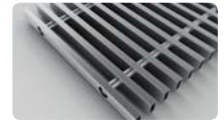

stainless



natur beech - wooden



stained beech - wooden



natur oak - wooden



stained oak - wooden

Linear non-rolling grilles



natur - anod. aluminium



bronze - anod. aluminium



black - anod. aluminium



(more on page 7)

More possibilities and variants → page 6



Trench heater heating output FRK 0125 0175/0200/0250/0300/0425

Q[W] 75/65/20 °C (ΔT=50 °C)

H×W [mm]	0125 0175	0125 0200	0125 0250	0125 0300	0125 0425
L [mm]	n=1,483	n=1,485	n=1,457	n=1,369	n=1,403
700	107 W	112 W	188 W	213 W	319 W
800	134 W	140 W	235 W	266 W	398 W
900	161 W	168 W	281 W	319 W	477 W
1000	187 W	196 W	328 W	372 W	556 W
1100	214 W	224 W	374 W	424 W	635 W
1200	240 W	251 W	421 W	477 W	714 W
1300	267 W	279 W	467 W	530 W	793 W
1400	293 W	307 W	514 W	583 W	872 W
1500	320 W	335 W	560 W	635 W	951 W
1600	346 W	363 W	607 W	688 W	1 030 W
1700	373 W	390 W	653 W	741 W	1 109 W
1800	399 W	418 W	700 W	793 W	1 187 W
1900	426 W	446 W	746 W	846 W	1 266 W
2000	452 W	474 W	793 W	899 W	1 345 W
2100	479 W	501 W	839 W	952 W	1 424 W
2200	505 W	529 W	886 W	1 004 W	1 503 W
2300	532 W	557 W	932 W	1 057 W	1 582 W
2400	559 W	585 W	978 W	1 110 W	1 661 W
2500	585 W	613 W	1 025 W	1 162 W	1 740 W
2600	612 W	640 W	1 071 W	1 215 W	1 819 W
2700	638 W	668 W	1 118 W	1 268 W	1 898 W
2800	665 W	696 W	1 164 W	1 321 W	1 977 W
2900	691 W	724 W	1 211 W	1 373 W	2 055 W
3000	718 W	751 W	1 257 W	1 426 W	2 134 W
3200	771 W	807 W	1 350 W	1 531 W	2 292 W
3400	824 W	863 W	1 443 W	1 637 W	2 450 W
3600	877 W	918 W	1 536 W	1 742 W	2 608 W
3800	930 W	974 W	1 629 W	1 848 W	2 766 W
4000	983 W	1 029 W	1 722 W	1 953 W	2 923 W
4200	1 036 W	1 085 W	1 815 W	2 059 W	3 081 W
4400	1 089 W	1 140 W	1 908 W	2 164 W	3 239 W
4600	1 142 W	1 196 W	2 001 W	2 270 W	3 397 W
4800	1 195 W	1 252 W	2 094 W	2 375 W	3 555 W

Q[W] 55/45/20 °C (ΔT=30 °C)

H×W [mm]	0125 0175	0125 0200	0125 0250	0125 0300	0125 0425
L [mm]	n=1,483	n=1,485	n=1,457	n=1,369	n=1,403
700	50 W	52 W	89 W	106 W	156 W
800	63 W	66 W	112 W	132 W	194 W
900	75 W	79 W	134 W	159 W	233 W
1000	88 W	92 W	156 W	185 W	272 W
1100	100 W	105 W	178 W	211 W	310 W
1200	112 W	118 W	200 W	237 W	349 W
1300	125 W	131 W	222 W	263 W	387 W
1400	137 W	144 W	244 W	290 W	426 W
1500	150 W	157 W	266 W	316 W	464 W
1600	162 W	170 W	288 W	342 W	503 W
1700	175 W	183 W	310 W	368 W	542 W
1800	187 W	196 W	333 W	394 W	580 W
1900	200 W	209 W	354 W	420 W	618 W
2000	212 W	222 W	377 W	447 W	657 W
2100	225 W	235 W	399 W	473 W	695 W
2200	237 W	248 W	421 W	499 W	734 W
2300	249 W	261 W	443 W	525 W	773 W
2400	262 W	274 W	465 W	552 W	811 W
2500	274 W	287 W	487 W	577 W	850 W
2600	287 W	300 W	509 W	604 W	888 W
2700	299 W	313 W	531 W	630 W	927 W
2800	312 W	326 W	553 W	656 W	966 W
2900	324 W	339 W	575 W	682 W	1 004 W
3000	337 W	352 W	597 W	709 W	1 042 W
3200	361 W	378 W	641 W	761 W	1 119 W
3400	386 W	404 W	686 W	814 W	1 197 W
3600	411 W	430 W	730 W	866 W	1 274 W
3800	436 W	456 W	774 W	918 W	1 351 W
4000	461 W	482 W	818 W	971 W	1 428 W
4200	486 W	508 W	862 W	1 023 W	1 505 W
4400	510 W	534 W	907 W	1 075 W	1 582 W
4600	535 W	560 W	951 W	1 128 W	1 659 W
4800	560 W	586 W	995 W	1 180 W	1 736 W

75/65/20 °C → 75 °C inlet temperature, 65 °C outlet temp., 20 °C room temp. / Output 90/70/20 °C = ~ 1,29 x 75/65/20 °C / Output 70/55/20 °C = ~ 0,80 x 75/65/20 °C / Heating outputs in accordance with EN442 / Not listed heating output for lengths per 100 mm steps calculate linearly.



Technical drawing

FRK 0125 0175

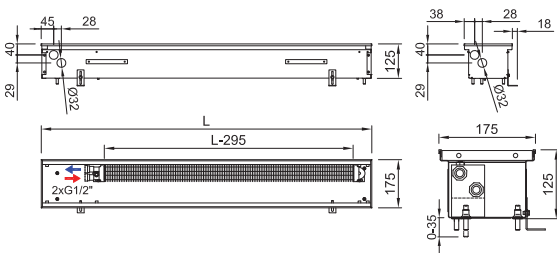

FRK 0125 0200

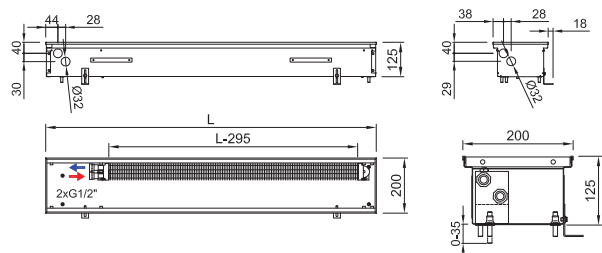

FRK 0125 0250

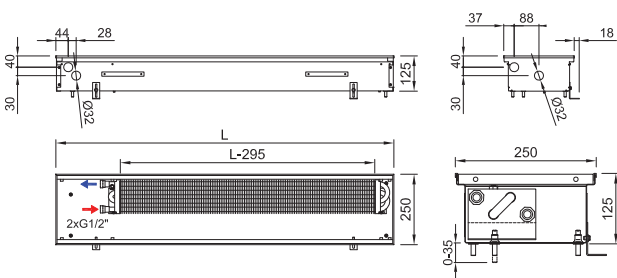

FRK 0125 0300

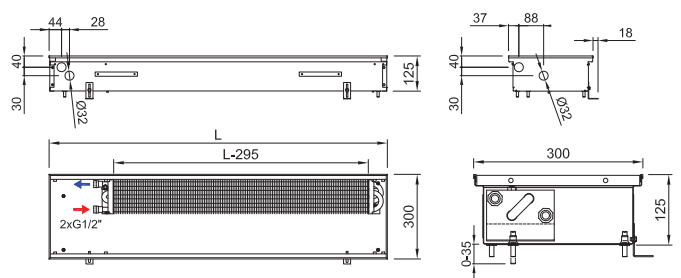

Connection to heating system

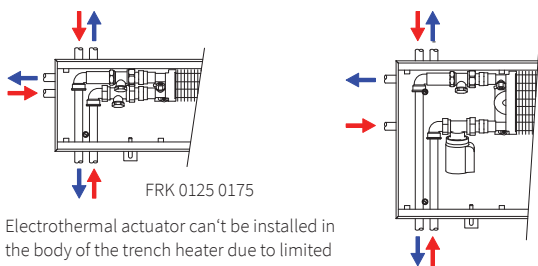

FRK 0125 0175
Electrothermal actuator can't be installed in the body of the trench heater due to limited internal space.

The hydraulic parameters of the heat exchanger → page 78

FRK 0125 0425

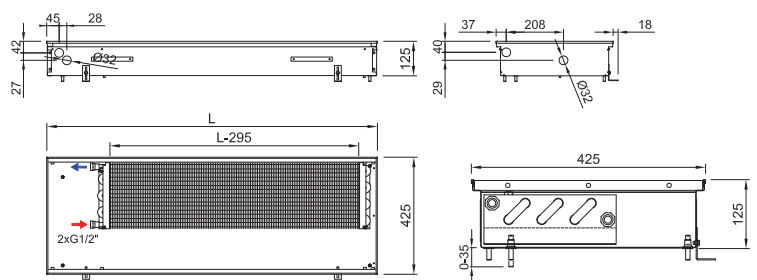

Trench heater standard equipment

Trough	Galvanized steel trough with surface finish and black spray layer inside, black cover plates of connection
Heat exchanger	Al-Cu lamellar exchanger with air vent valve, black painted
Grille	Design walkable grille according to the customer's choice*
Ledge	Made of anodized aluminium, type and colour according to the customer's choice
Assembly elements	Leveling screws for setting up the trough, mounting brackets
Manual	Manual for the progress of work during installation and user manual
Wiring	Electrical wiring diagram of the trench heaters
Mounting board	Cover and the spacer particle board for easy installation
Package	Transport package for protection against damage during transportation and handling

*stainless grilles surcharge

Accessories per order



Accessories details → page 60

Code example: FRK 0125 0250 1500 C 62 L2 L - 0

Trench heater **FRK** H=125 mm, W=250 mm, L=1 500 mm, „**C**“ Galvanized steel trough with black inside, heat exchanger and inner parts painted black, „**62**“ stained beech grille, transverse, roll-up, „**L2**“ peripheral ledge „**L**“ with an overlap, bronze anodized aluminium, „**L**“ water connection at the left side (when installing the heat exchanger closer to the window, fans to the room), „**0**“ trench heater with natural convection

FRK 0140 0175/0200/0250/0300/0425

TRENCH HEATERS WITH NATURAL CONVECTION



- Offices, corridors, halls, flats, winter garden
- High heating output of natural convection
- Suitable for combining with other heating systems
- Using in dry environment
- 2pipe system

Technical data

Trench heater

Height	H = 140 mm
Width	W = 175, 200, 250, 300, 425 mm
Length	L = 700-4 800 mm in step 100 mm

Heat exchanger

Type	Al-Cu lamellar
Length	L- 295 mm
Connection thread	2×G1/2" inner

Working conditions

Max. temperature	110 °C
Max. overpressure	1 MPa (10 bar)
Protection	IP 20

Ambient conditions	Temp. T = +2 to +40 °C Humidity Rh = 20 to 70 %
--------------------	--



FRK 0140 0175

Variants

Transverse roll-up grilles

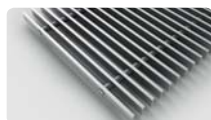

natur - anod. aluminium



bronze - anod. aluminium



black - anod. aluminium

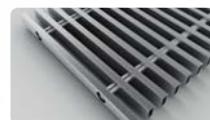

stainless



natur beech - wooden



stained beech - wooden



natur oak - wooden



stained oak - wooden

Linear non-rolling grilles



natur - anod. aluminium



bronze - anod. aluminium



black - anod. aluminium

Peripheral ledges



(more on page 7)

More possibilities and variants → page 6



Trench heater heating output FRK 0140 0175/0200/0250/0300/0425

Q[W] 75/65/20 °C (ΔT=50 °C)

H×W [mm]	0140 0175	0140 0200	0140 0250	0140 0300	0140 0425
L [mm]	n=1,495	n=1,496	n=1,443	n=1,453	n=1,403
700	111 W	116 W	200 W	223 W	354 W
800	138 W	145 W	249 W	278 W	441 W
900	165 W	174 W	298 W	333 W	528 W
1000	192 W	203 W	347 W	389 W	615 W
1100	220 W	231 W	396 W	444 W	703 W
1200	247 W	260 W	446 W	499 W	790 W
1300	274 W	289 W	495 W	554 W	877 W
1400	301 W	317 W	544 W	609 W	964 W
1500	329 W	346 W	593 W	664 W	1 052 W
1600	356 W	375 W	642 W	719 W	1 139 W
1700	383 W	404 W	692 W	774 W	1 226 W
1800	411 W	432 W	741 W	829 W	1 314 W
1900	438 W	461 W	790 W	885 W	1 401 W
2000	465 W	490 W	839 W	940 W	1 488 W
2100	492 W	519 W	889 W	995 W	1 575 W
2200	520 W	547 W	938 W	1 050 W	1 663 W
2300	547 W	576 W	987 W	1 105 W	1 750 W
2400	574 W	605 W	1 036 W	1 160 W	1 837 W
2500	602 W	633 W	1 085 W	1 215 W	1 925 W
2600	629 W	662 W	1 135 W	1 270 W	2 012 W
2700	656 W	691 W	1 184 W	1 325 W	2 099 W
2800	683 W	720 W	1 233 W	1 381 W	2 186 W
2900	711 W	748 W	1 282 W	1 436 W	2 274 W
3000	738 W	777 W	1 332 W	1 491 W	2 361 W
3200	793 W	835 W	1 430 W	1 601 W	2 536 W
3400	847 W	892 W	1 528 W	1 711 W	2 710 W
3600	902 W	949 W	1 627 W	1 821 W	2 885 W
3800	956 W	1 007 W	1 725 W	1 932 W	3 059 W
4000	1 011 W	1 064 W	1 824 W	2 042 W	3 234 W
4200	1 065 W	1 122 W	1 922 W	2 152 W	3 408 W
4400	1 120 W	1 179 W	2 021 W	2 262 W	3 583 W
4600	1 174 W	1 237 W	2 119 W	2 373 W	3 757 W
4800	1 229 W	1 294 W	2 218 W	2 483 W	3 932 W

Q[W] 55/45/20 °C (ΔT=30 °C)

H×W [mm]	0140 0175	0140 0200	0140 0250	0140 0300	0140 0425
L [mm]	n=1,495	n=1,496	n=1,443	n=1,453	n=1,403
700	52 W	54 W	96 W	106 W	173 W
800	64 W	68 W	119 W	132 W	215 W
900	77 W	81 W	143 W	159 W	258 W
1000	89 W	95 W	166 W	185 W	300 W
1100	103 W	108 W	189 W	211 W	343 W
1200	115 W	121 W	213 W	238 W	386 W
1300	128 W	135 W	237 W	264 W	428 W
1400	140 W	148 W	260 W	290 W	471 W
1500	153 W	161 W	284 W	316 W	514 W
1600	166 W	175 W	307 W	342 W	556 W
1700	179 W	188 W	331 W	368 W	599 W
1800	192 W	201 W	355 W	395 W	642 W
1900	204 W	215 W	378 W	421 W	684 W
2000	217 W	228 W	401 W	447 W	727 W
2100	229 W	242 W	425 W	474 W	769 W
2200	242 W	255 W	449 W	500 W	812 W
2300	255 W	268 W	472 W	526 W	854 W
2400	268 W	282 W	496 W	552 W	897 W
2500	281 W	295 W	519 W	578 W	940 W
2600	293 W	308 W	543 W	604 W	982 W
2700	306 W	322 W	567 W	631 W	1 025 W
2800	318 W	335 W	590 W	657 W	1 067 W
2900	331 W	348 W	613 W	684 W	1 110 W
3000	344 W	362 W	637 W	710 W	1 153 W
3200	370 W	389 W	684 W	762 W	1 238 W
3400	395 W	415 W	731 W	814 W	1 323 W
3600	420 W	442 W	778 W	867 W	1 409 W
3800	446 W	469 W	825 W	920 W	1 494 W
4000	471 W	495 W	873 W	972 W	1 579 W
4200	496 W	522 W	920 W	1 024 W	1 664 W
4400	522 W	549 W	967 W	1 077 W	1 749 W
4600	547 W	576 W	1 014 W	1 129 W	1 834 W
4800	573 W	603 W	1 061 W	1 182 W	1 920 W

75/65/20 °C → 75 °C inlet temperature, 65 °C outlet temp., 20 °C room temp. / Output 90/70/20 °C = ~ 1,29 x 75/65/20 °C / Output 70/55/20 °C = ~ 0,80 x 75/65/20 °C / Heating outputs in accordance with EN442 / Not listed heating output for lengths per 100 mm steps calculate linearly.



Technical drawing

FRK 0140 0175

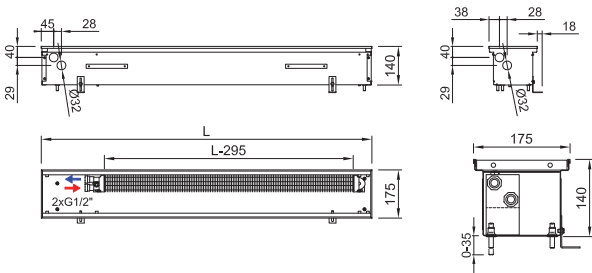

FRK 0140 0200

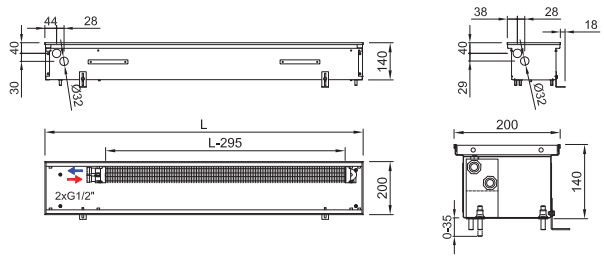

FRK 0140 0250

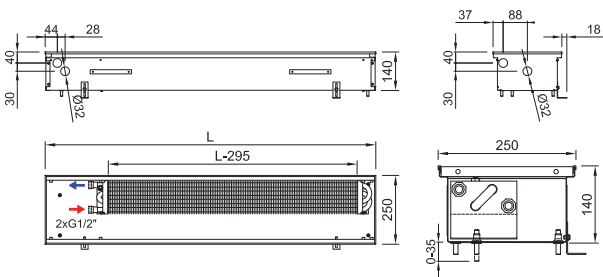

FRK 0140 0300

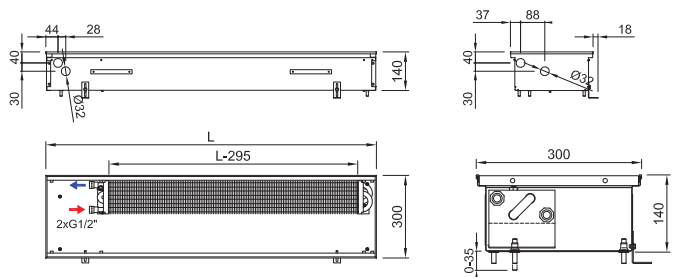

Connection to heating system

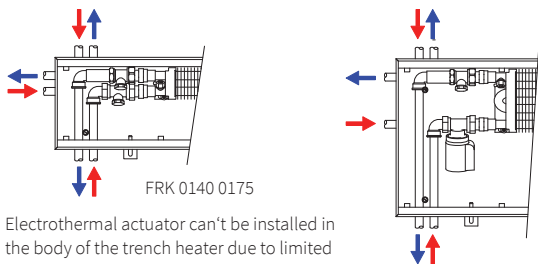

FRK 0140 0175
Electrothermal actuator can't be installed in the body of the trench heater due to limited internal space.

The hydraulic parameters of the heat exchanger → page 78

FRK 0140 0425

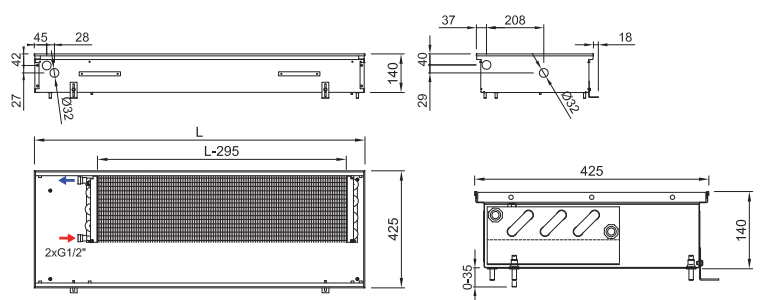

Trench heater standard equipment

Trough	Galvanized steel trough with surface finish and black spray layer inside, black cover plates of connection
Heat exchanger	Al-Cu lamellar exchanger with air vent valve, black painted
Grille	Design walkable grille according to the customer's choice*
Ledge	Made of anodized aluminium, type and colour according to the customer's choice
Assembly elements	Leveling screws for setting up the trough, mounting brackets
Manual	Manual for the progress of work during installation and user manual
Wiring	Electrical wiring diagram of the trench heaters
Mounting board	Cover and the spacer particle board for easy installation
Package	Transport package for protection against damage during transportation and handling

*stainless grilles surcharge

Accessories per order



Accessories details → page 60

Code example: FRK 0140 0425 1400 C 63 L1 L - 0

Trench heater **FRK H=140 mm, W=425 mm, L=1 400 mm**, „C“ Galvanized steel trough with black inside, heat exchanger and inner parts painted black, „63“ natural oak grille, transverse, roll-up, „L1“ peripheral ledge „L“ with an overlap, natur anodized aluminium „L“ water connection at the left side (when installing the heat exchanger closer to the window, fans to the room), „0“ trench heater with natural convection

FRK 0165 0300/0425

TRENCH HEATERS WITH NATURAL CONVECTION



- Offices, corridors, halls, flats, winter garden
- High heating output of natural convection
- Suitable for combining with other heating systems
- Using in dry environment
- 2pipe system



Technical data

Trench heater

Height	H = 165 mm
Width	W = 300, 425 mm
Length	L = 700-4 800 mm in step 100 mm

Heat exchanger

Type	Al-Cu lamellar
Length	L- 295 mm
Connection thread	2xG1/2" inner

Working conditions

Max. temperature	110 °C
Max. overpressure	1 MPa (10 bar)
Protection	IP 20

Ambient conditions	Temp. T = +2 to +40 °C Humidity Rh = 20 to 70 %
--------------------	--

Variants

Transverse roll-up grilles

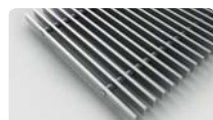

natur - anod. aluminium



bronze - anod. aluminium



black - anod. aluminium

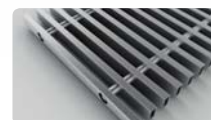

stainless



natur beech - wooden



stained beech - wooden



natur oak - wooden



stained oak - wooden

Linear non-rolling grilles



natur - anod. aluminium



bronze - anod. aluminium



black - anod. aluminium

Peripheral ledges



(more on page 7)

More possibilities and variants → page 6



Trench heater heating output FRK 0165 0300/0425

Q[W] 75/65/20 °C (ΔT=50 °C)

H×W [mm]	0165 0300	0165 0425
L [mm]	n=1,457	n=1,442
700	233 W	401 W
800	291 W	500 W
900	349 W	599 W
1000	406 W	698 W
1100	464 W	797 W
1200	521 W	896 W
1300	579 W	995 W
1400	637 W	1 094 W
1500	694 W	1 193 W
1600	752 W	1 292 W
1700	809 W	1 391 W
1800	867 W	1 490 W
1900	925 W	1 589 W
2000	982 W	1 688 W
2100	1 040 W	1 787 W
2200	1 097 W	1 886 W
2300	1 155 W	1 985 W
2400	1 213 W	2 084 W
2500	1 270 W	2 183 W
2600	1 328 W	2 282 W
2700	1 385 W	2 381 W
2800	1 443 W	2 480 W
2900	1 501 W	2 579 W
3000	1 558 W	2 678 W
3200	1 673 W	2 876 W
3400	1 789 W	3 074 W
3600	1 904 W	3 272 W
3800	2 019 W	3 470 W
4000	2 134 W	3 668 W
4200	2 250 W	3 866 W
4400	2 365 W	4 064 W
4600	2 480 W	4 262 W
4800	2 595 W	4 460 W

Q[W] 55/45/20 °C (ΔT=30 °C)

H×W [mm]	0165 0300	0165 0425
L [mm]	n=1,457	n=1,442
700	111 W	192 W
800	138 W	239 W
900	166 W	287 W
1000	193 W	334 W
1100	220 W	382 W
1200	248 W	429 W
1300	275 W	476 W
1400	303 W	524 W
1500	330 W	571 W
1600	357 W	619 W
1700	384 W	666 W
1800	412 W	713 W
1900	440 W	761 W
2000	467 W	808 W
2100	494 W	856 W
2200	521 W	903 W
2300	549 W	950 W
2400	576 W	998 W
2500	603 W	1 045 W
2600	631 W	1 093 W
2700	658 W	1 140 W
2800	686 W	1 187 W
2900	713 W	1 235 W
3000	740 W	1 282 W
3200	795 W	1 377 W
3400	850 W	1 472 W
3600	905 W	1 567 W
3800	959 W	1 661 W
4000	1 014 W	1 756 W
4200	1 069 W	1 851 W
4400	1 124 W	1 946 W
4600	1 178 W	2 041 W
4800	1 233 W	2 135 W

75/65/20 °C → 75 °C inlet temperature, 65 °C outlet temp., 20 °C room temp. / **Output 90/70/20 °C** = ~ 1,29 x 75/65/20 °C / **Output 70/55/20 °C** = ~ 0,80 x 75/65/20 °C / Heating outputs in accordance with EN442 / Not listed heating outputs for lengths per 100 mm steps calculate linearly.



Technical drawing

FRK 0165 0300

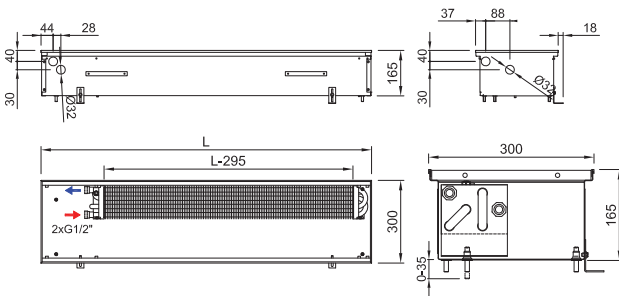

FRK 0165 0425

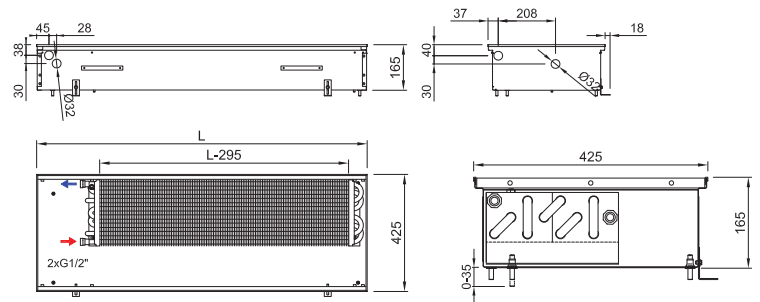

Connection to heating system

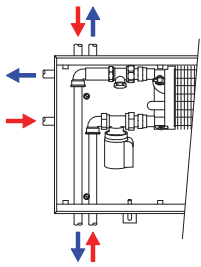







The hydraulic parameters of the heat exchanger → page 78

Trench heater standard equipment

Trough	Galvanized steel trough with surface finish and black spray layer inside, black cover plates of connection
Heat exchanger	Al-Cu lamellar exchanger with air vent valve, black painted
Grille	Design walkable grille according the customer's choice*
Ledge	Made of anodized aluminium, type and colour according the customer's choice
Assembly elements	Leveling screws for setting up the trough, mounting brackets
Manual	Manual for the progress of work during installation and user manual
Wiring	Electrical wiring diagram of the trench heaters
Mounting board	Cover and the spacer particle board for easy installation
Package	Transport package for protection against damage during transportation and handling

*stainless grilles surcharge

Accessories per order

	Manual thermostat		Room thermostat with a capillary
	Electrothermal actuator		Power supply
	Lockshield valve		Thermostatic valve

Accessories details → page 60

Code example: FRK 0165 0300 1900 C 52 J1 R - 0

Trench heater **FRK** H=165 mm, W= 300 mm, L=1 900 mm, „C“ Galvanized steel trough with black inside, heat exchanger and inner parts painted black, „52“ stainless grille, transverse, roll-up, „J1“ peripheral ledge „J“, natur anodized aluminium, „R“ water connection at the right side (when installing the heat exchanger closer to the window, fans to the room), „0“ trench heater with natural convection

FRK 0200 0300/0425

TRENCH HEATERS WITH NATURAL CONVECTION



- Offices, corridors, halls, flats, winter garden
- High heating output of natural convection
- Suitable for combining with other heating systems
- Using in dry environment
- 2pipe system



Technical data

Trench heater

Height	H = 200 mm
Width	W = 300, 425 mm
Length	L = 700-4 800 mm in step 100 mm

Heat exchanger

Type	Al-Cu lamellar
Length	L- 295 mm
Connection thread	2xG1/2" inner

Working conditions

Max. temperature	110 °C
Max. overpressure	1 MPa (10 bar)
Protection	IP 20

Ambient conditions	Temp. T = +2 to +40 °C Humidity Rh = 20 to 70 %
--------------------	--

Variants

Transverse roll-up grilles

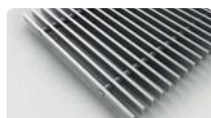

natur - anod. aluminium

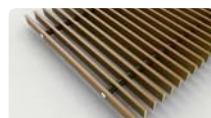

bronze - anod. aluminium



black - anod. aluminium

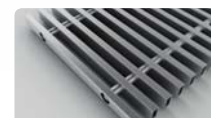

stainless



natur beech - wooden



stained beech - wooden



natur oak - wooden



stained oak - wooden

Linear non-rolling grilles



natur - anod. aluminium



bronze - anod. aluminium



black - anod. aluminium

Peripheral ledges



(more on page 7)

More possibilities and variants → page 6

Trench heater heating output FRK 0200 0300/0425

Q[W] 75/65/20 °C (ΔT=50 °C)

HxW [mm]	0200 0300	0200 0425
L [mm]	n=1,462	n=1,461
700	237 W	435 W
800	296 W	542 W
900	354 W	649 W
1000	413 W	756 W
1100	471 W	864 W
1200	530 W	971 W
1300	588 W	1 078 W
1400	647 W	1 185 W
1500	706 W	1 293 W
1600	764 W	1 400 W
1700	823 W	1 507 W
1800	881 W	1 615 W
1900	940 W	1 722 W
2000	998 W	1 829 W
2100	1 057 W	1 936 W
2200	1 115 W	2 044 W
2300	1 174 W	2 151 W
2400	1 233 W	2 258 W
2500	1 291 W	2 366 W
2600	1 350 W	2 473 W
2700	1 408 W	2 580 W
2800	1 467 W	2 687 W
2900	1 525 W	2 795 W
3000	1 584 W	2 902 W
3200	1 701 W	3 117 W
3400	1 818 W	3 331 W
3600	1 935 W	3 546 W
3800	2 052 W	3 760 W
4000	2 169 W	3 975 W
4200	2 287 W	4 189 W
4400	2 404 W	4 404 W
4600	2 521 W	4 618 W
4800	2 638 W	4 833 W

Q[W] 55/45/20 °C (ΔT=30 °C)

HxW [mm]	0200 0300	0200 0425
L [mm]	n=1,462	n=1,461
700	112 W	206 W
800	140 W	257 W
900	168 W	308 W
1000	196 W	358 W
1100	223 W	410 W
1200	251 W	460 W
1300	279 W	511 W
1400	307 W	562 W
1500	335 W	613 W
1600	362 W	664 W
1700	390 W	715 W
1800	417 W	766 W
1900	445 W	816 W
2000	473 W	867 W
2100	501 W	918 W
2200	528 W	969 W
2300	556 W	1 020 W
2400	584 W	1 071 W
2500	612 W	1 122 W
2600	640 W	1 173 W
2700	667 W	1 223 W
2800	695 W	1 274 W
2900	723 W	1 325 W
3000	751 W	1 376 W
3200	806 W	1 478 W
3400	861 W	1 579 W
3600	917 W	1 681 W
3800	972 W	1 783 W
4000	1 028 W	1 885 W
4200	1 084 W	1 986 W
4400	1 139 W	2 088 W
4600	1 194 W	2 190 W
4800	1 250 W	2 291 W

75/65/20 °C → 75 °C inlet temperature, 65 °C outlet temp., 20 °C room temp. / **Output 90/70/20 °C** = ~ 1,29 x 75/65/20 °C / **Output 70/55/20 °C** = ~ 0,80 x 75/65/20 °C / Heating outputs in accordance with EN442 / Not listed heating outputs for lengths per 100 mm steps calculate linearly.



Technical drawing

FRK 0200 0300

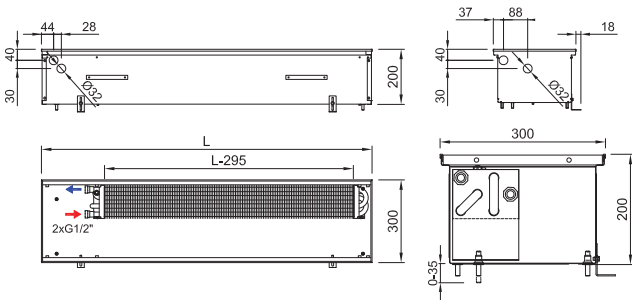

FRK 0200 0425

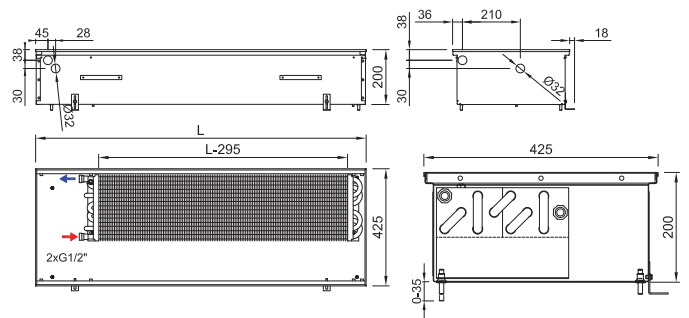

Connection to heating system

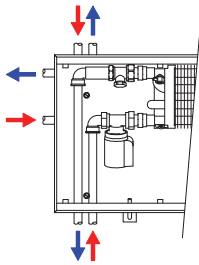







The hydraulic parameters of the heat exchanger → page 78

Trench heater standard equipment

- Trough** Galvanized steel trough with surface finish and black spray layer inside, black cover plates of connection
- Heat exchanger** Al-Cu lamellar exchanger with air vent valve, black painted
- Grille** Design walkable grille according the customer's choice*
- Ledge** Made of anodized aluminium, type and colour according the customer's choice
- Assembly elements** Leveling screws for setting up the trough, mounting brackets
- Manual** Manual for the progress of work during installation and user manual
- Wiring** Electrical wiring diagram of the trench heaters
- Mounting board** Cover and the spacer particle board for easy installation
- Package** Transport package for protection against damage during transportation and handling

*stainless grilles surcharge

Accessories per order

-  Manual thermostat
-  Room thermostat with a capillary
-  Electrothermal actuator
-  Power supply
-  Lockshield valve
-  Thermostatic valve

Accessories details → page 60

Code example: FRK 0200 0425 1500 C 62 L2 L - 0

Trench heater **FRK** H=200 mm, W= 425 mm, L=1 500 mm, „C” Galvanized steel trough with black inside, heat exchanger and inner parts painted black, „62” stained beech grille, transverse, roll-up, „L2” peripheral ledge „L” with an overlap, bronze anodized aluminium, „L” water connection at the left side (when installing the heat exchanger closer to the window, fans to the room), „0” trench heater with natural convection

Atypical trench heaters

Folded and cranked

Use broken-line trench heaters to cover heat losses from glassed-in surfaces copying irregular ground plans of rooms. We supply both acute and obtuse angles and multiple cranked trench heaters.

Folded trench heaters comprising from multiple units can be installed in front of long glassed-in surfaces. The trench heater is equipped with a grille from one or multiple pieces which looks like a single long piece at the first sight. Specification of the trench heater location and approval of the design documentation by the customer are required before the start of the production.



ALUMINIUM

transverse grilles
TYPE: 15, 25, 35

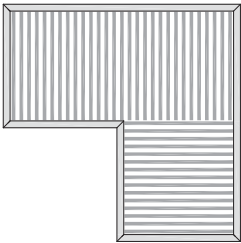

90° angle only

transverse roll-up grilles
TYPE: 11, 21, 31

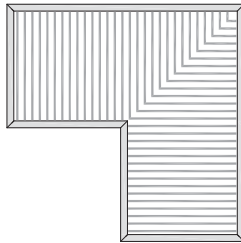

angle 40°– 320°

linear non-rolling grilles
TYPE: 12, 22, 32

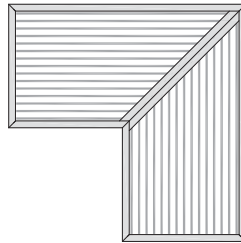

angle 40°– 320°

WOOD

roll-up grilles
TYPE: 61, 62, 63, 64

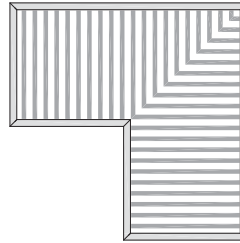

angle 40°– 320°

STAINLESS

roll-up grilles
TYPE: 51, 52

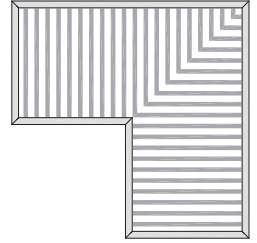

90° angle only

more about grilles on page 6

Examples

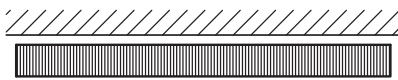

trench heater section length

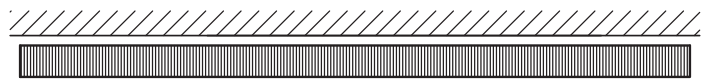

long trench heater, usually composed of multiple internal units

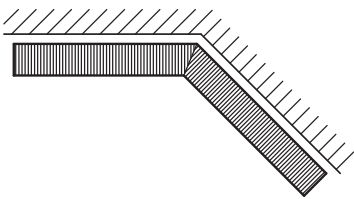

pointed towards inside

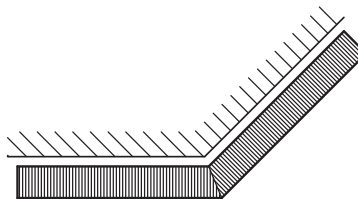

pointed towards outside

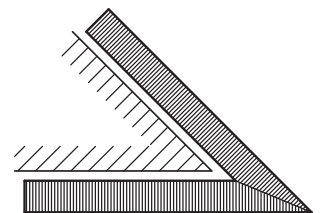

pointed - acute angle

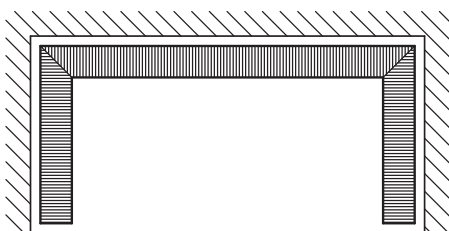

2× pointed towards inside

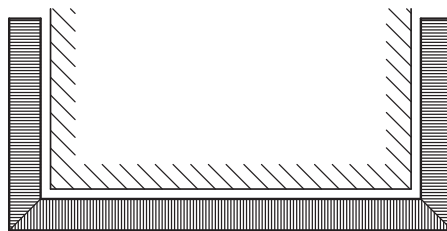

2× pointed towards outside

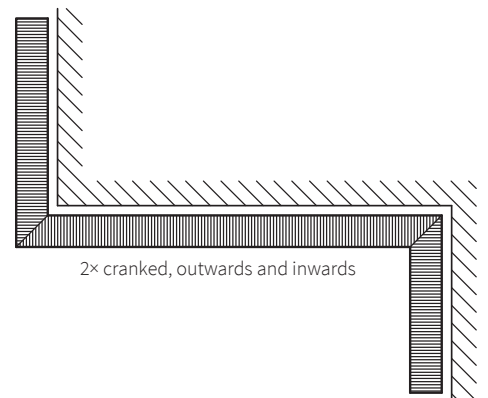

2× cranked, outwards and inwards

Atypical trench heaters

Arched

Modern structures with glassed-in arched sections can be equipped with rounded trench heaters. Windows are of arched or multiple broken-line shapes. The arch must follow the running line of the glassed-in surface. The trench heater's location must be measured at the construction site since the actual ground plan frequently differs from the design. Please consult this type of the trench heater in advance with the Technical Department.



Examples

arc inwards

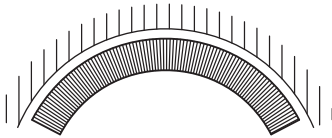

shallow outer arc

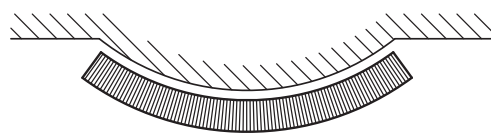

outer arc

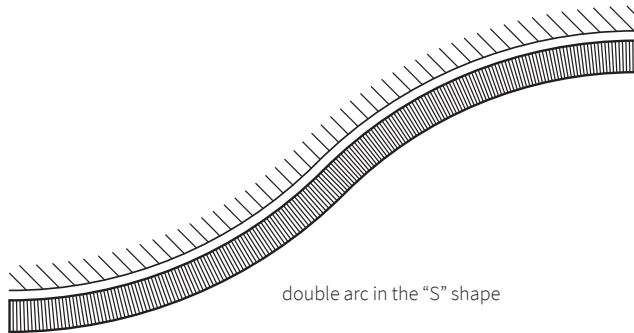
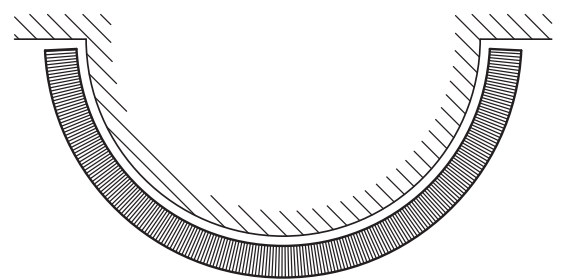

double arc in the "S" shape

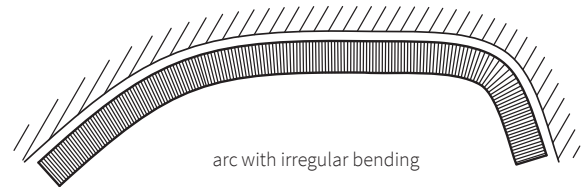

arc with irregular bending

Cutouts in trench heaters

Trench heaters frequently intersect component parts of the structure, such as columns and partition walls. Columns may be fully incorporated in a trench heater or they can only interfere with it. A grille bypasses the column.

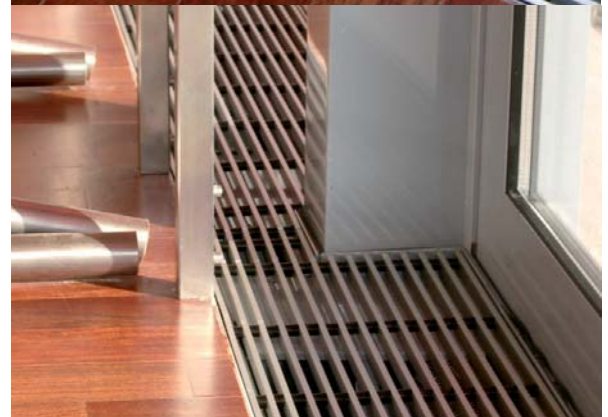
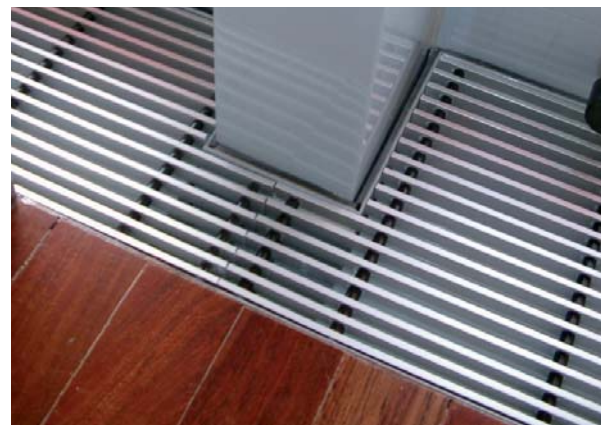
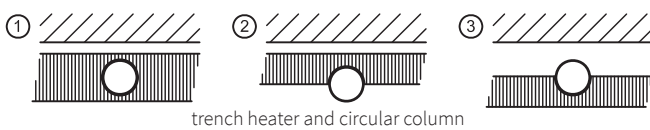
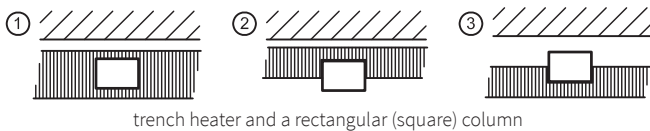

Heat exchanger - Hydraulic resistance

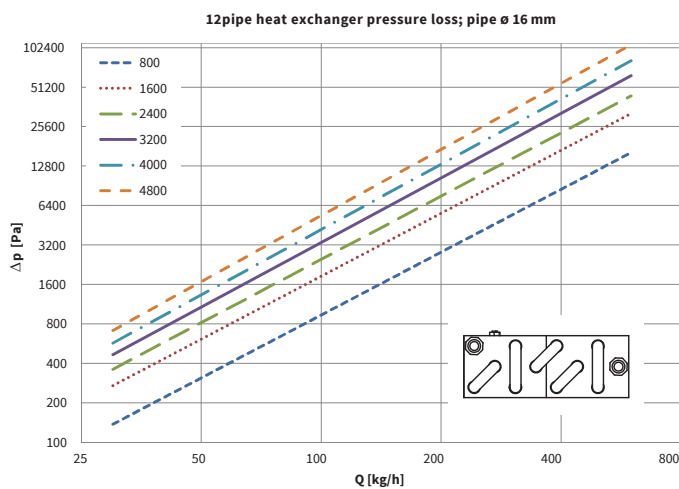
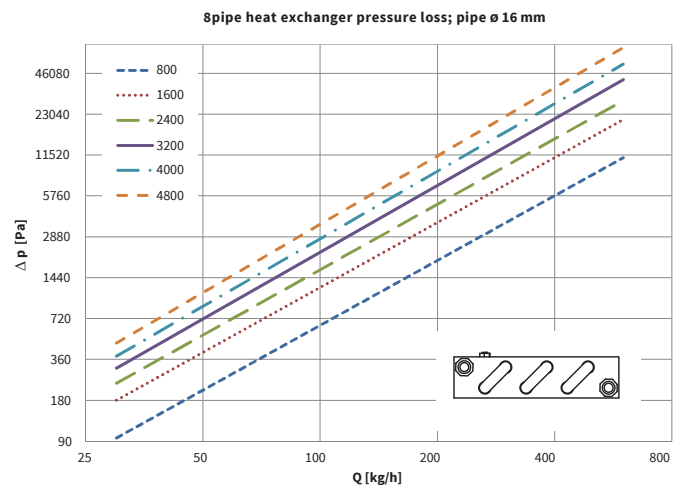
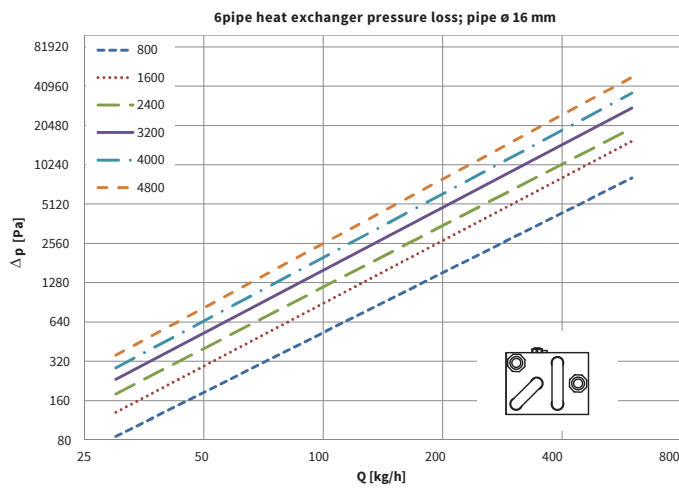
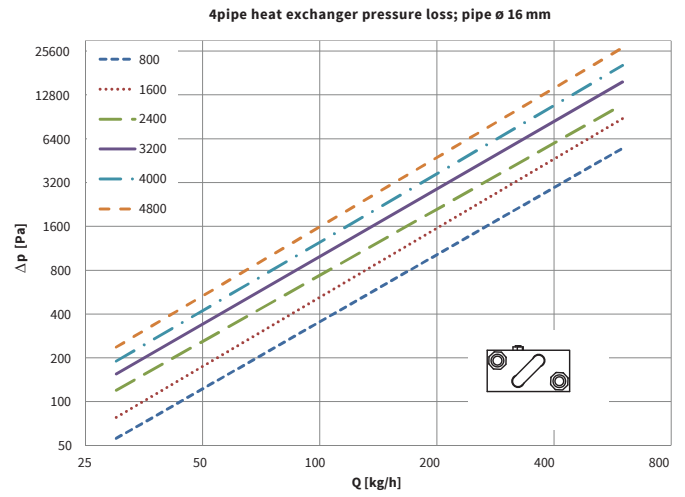
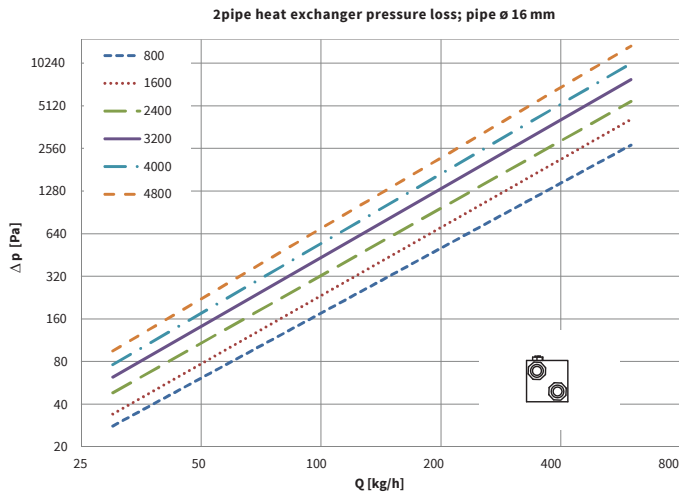

Electric connection of trench heaters with fan

The trench heaters and their components are powered with safe direct current voltage of 24 V DC. The low voltage requires specific sizing of the network. Based on the number of installed units it is necessary to assess the total input of the circuit and size the capacity of the power source and the cross sections of the conductors in the circuit shall be correctly sized with respect to the distances between individual heating bodies and the switched source of the voltage of 24 V DC. The total input of the bodies is considered for maximal speed (i.e. speed no. 4), if the electrothermal actuator is used we will add its operating input. The voltage in the circuit may not, in any point, drop below the value of 22 V DC.

Procedure of the network sizing

1. Consider the trench heater's input for speed 4 from the table.
2. If the electrothermal actuator is considered, add its input.
3. Determine the position for the installation of the switched power supply for the voltage of 24 V DC, this position shall be as close to installed trench heaters as possible.
4. Record the distances between the bodies and the source from the project.
5. Determine the lines of the electric network.
6. Calculate the decline of voltage in individual bodies.
7. If the voltage at all heating bodies is >22 V DC, determine the power supply's capacity, consider the output reserve of 5% (see SCHEME 1 on page 80).
8. If the voltage along the network lines drops below 22 V DC, size a large cross section of conductors or install additional power supply on the lines (see SCHEME 3 on page 81).
9. When installing more than 10 trench heaters it is necessary to incorporate a switching relay RL10 in the circuit, (see SCHEME 2 on page 80).

Setting the thermostat RTD201

It is necessary to carry out basic presetting before the first start-up to secure the correct function of the thermostat:

DIP SWITCH

Switch the switch 1 on the back side of the thermostat to position ON. The other switches will remain in the OFF position. With this the 2pipe heating system has been preset.

SERVICE LEVEL - PARAMETERS

The „service level“ contains a small set of parameters for the adjustment of the regulator to the HVAC system and for the setting of the user's interface. These parameters may usually be set at any time.

SET

P01 = 0 the setting of the heating mode

EXPERT LEVEL - PARAMETERS

The parameters in the "Expert level" shall be adjusted with great care because they influence the regulation process and the regulator's function.

SETTING

- P38 = 0** the thermostat will function only in the heating mode
- P55 = 100%** maximal speed, in the case of need the maximal speed may be limited with this parameter (e.g. P55 = 60%)
- P56 = 20%** minimal speed
- P72 = 2** setting the opening of the thermal actuator to the thermostat's terminal Q1

If the speed blocking sensor TE30 is to be used it is necessary to change the inner setting of the thermostat.



Electrical diagram

SCHEME 1 - basic connection

Note

- The voltage must not drop below 22 V DC, it is necessary to size the cross section of conductors correctly according to the calculation SW.
- If more than 10 electrothermal actuators are used it is necessary to use the switching relay (see SCHEME 2).
- If the capacity of the switching source is insufficient use more power supplies (see SCHEME 3).

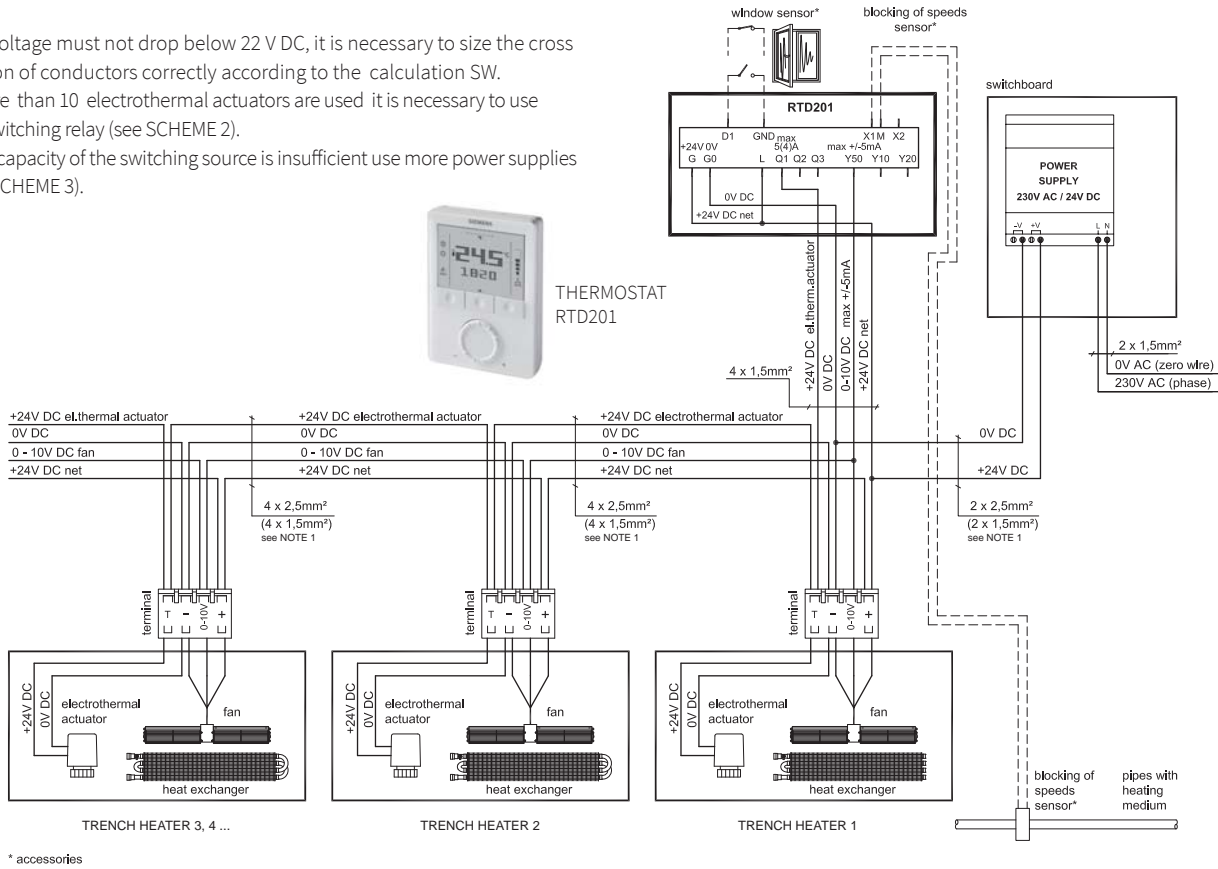

SCHEME 2 - connection with more than 10pcs of electrothermal actuator

Note

- The voltage must not drop below 22 V DC, it is necessary to size the cross section of conductors correctly according to the calculation SW.
- If the capacity of the switching source is insufficient use more power supplies (see SCHEME 3).

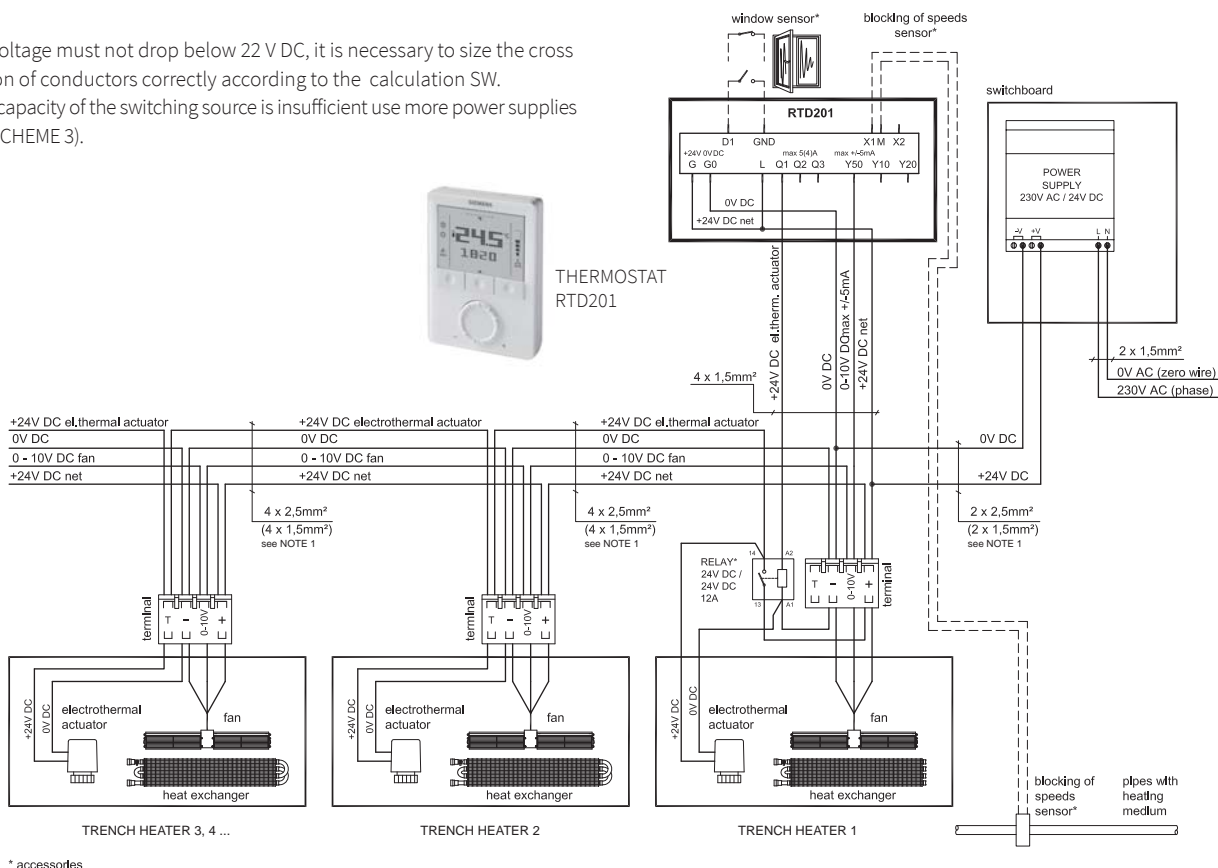

Electrical diagrams

SCHEME 3 - connection with more supplies

Note

- The voltage must not drop below 22 V DC, it is necessary to size the cross section of conductors correctly according to the calculation SW.
- If more than 10 electrothermal actuators are used it is necessary to use the switching relay (see DIAGRAM 2).
- All sources shall be powered from a single circuit breaker.

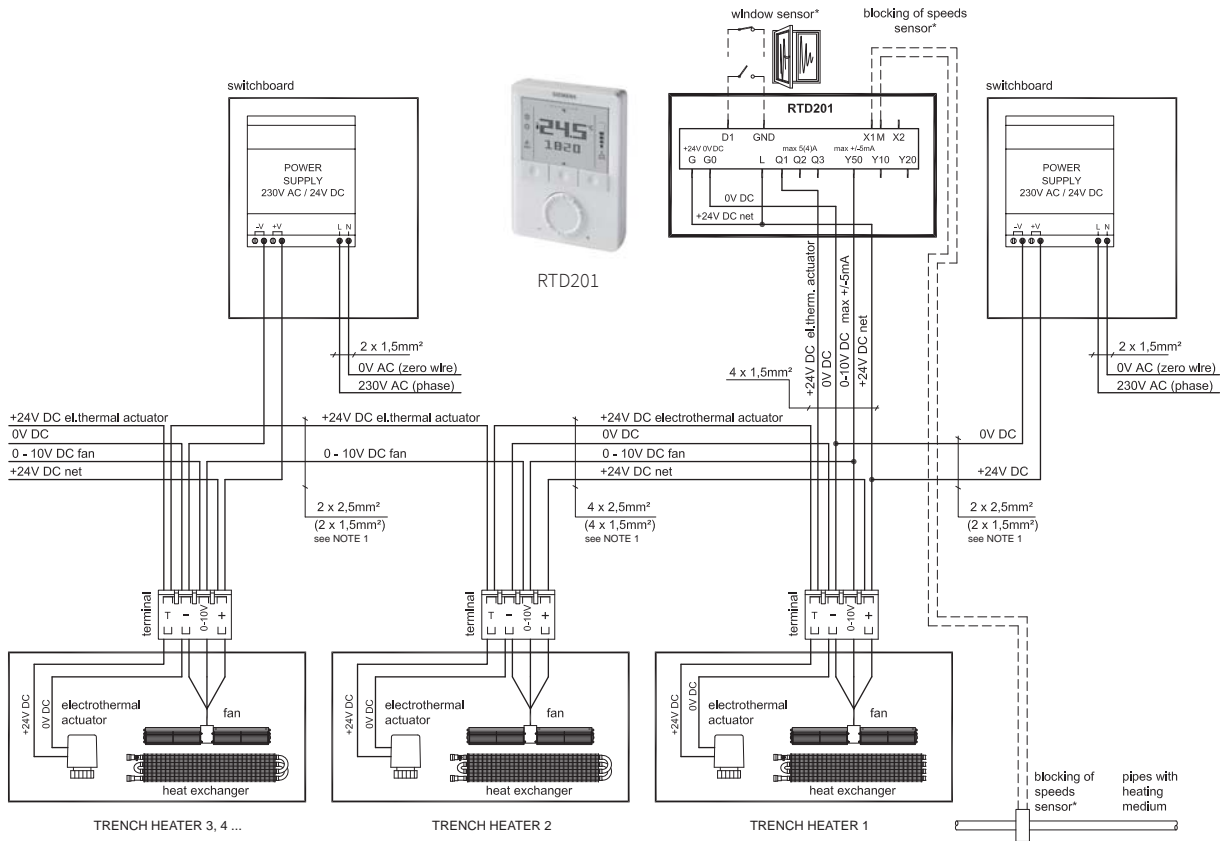

* accessories

The coding of trench heaters

New Practic

1	2	3	4	5	6	7	8	9	10	11	12	13	14	15	16	17	18	19	20	21	22	23	24		
F	R	T	0	1	1	0	0	2	5	0	1	2	0	0	C	1	2	J	1	L	B	5			
PRODUCT	LINE	TYPE	HEIGHT [mm]				WIDTH [mm]				LENGTH [mm]				TROUGH & COMPONENTS		GRILLE, TYPE AND COLOUR		LEDGE Colour OF LEDGE		WATER CONNECTION LEFT / RIGHT		SELFSTANDING	REGULATION	ATYPICAL / STANDARD

Code description

Trench heater **FRT** H = **110** mm, W = **250** mm, L = **1 200** mm, „**C**“ Galvanized steel trough with black inside, heat exchanger and inner parts painted black, „**12**“ natur anodized aluminium grille, linear, rigid, „**J1**“ peripheral ledge „**J**“, natur anodized aluminium, „**L**“ water connection at the left side (when installing the heat exchanger closer to the window, fans to the room), „**B**“ selfstanding 0-35 mm „**5**“ 24 V DC fans without controller (controller is not needed)

1	PRODUCT	F	Fancoil, trench heater, trench heating
2	LINE	R	New Practic
3	TYPE	K	Without fan
		T	With tangential fan
4-7	HEIGHT [mm]	for example 0090	FRT height 0065, 0080, 0090, 0110, 0125, 0140
			FRK height 0080, 0090, 0110, 0125, 0140, 0165, 0200
8-11	WIDTH [mm]	for example 0175	Width [mm] 175, 200, 250, 300, 425 mm
12-15	LENGTH [mm]	700 to 4800	Standard lengths are 700 to 4 800 mm, in step of 100 mm (atypical lengths according to individual offer)
			0700, 0800, 0900, 1000, 1100, 1200, 1300, 1400, 1500, 1600, 1700, 1800, 1900, 2000, 2100, 2200, 2300, 2400, 2500, 2600, 2700, 2800, 2900, 3000, 3100, 3200, 3300, 3400, 3500, 3600, 3700, 3800, 3900, 4000, 4100, 4200, 4300, 4400, 4500, 4600, 4700, 4800
16	TROUGH & INNER COMPONENTS	C	Galvanized steel trough with surface finish and black spray layer inside, light colour outside, internal components are black (standard)
		N	Trough made of stainless steel
17-18	GRILLES	00	WITHOUT THE Grille, the trench heater without the grille (the customer will supply their own grille or buy one later)
		11	NATUR aluminium roll-up transverse grille
		12	NATUR aluminium linear non-rolling grille
		15	NATUR aluminium low transverse grille
		21	BRONZE aluminium roll-up transverse grille
		22	BRONZE aluminium linear non-rolling grille
		25	BRONZE aluminium low transverse grille
		31	BLACK aluminium roll-up transverse grille
		32	BLACK aluminium linear non-rolling grille
		35	BLACK aluminium low transverse grille
		51	STAINLESS non-rolling transverse grille of stainless steel jäkl profiles 20x10 mm (for car saloons)
		52	STAINLESS roll-up transverse grille of stainless steel jäkl profiles 20x10 mm
		61	BEECH NATUR wooden roll-up transverse grille without surface finish
		62	STAINED BEECH wooden roll-up transverse grille with stained surface finish
		63	OAK NATUR wooden roll-up transverse grille without surface finish
		64	STAINED OAK wooden roll-up transverse grille with stained surface finish
99	ATYP - material, spacing of lamellas, surface finish according to RAL, after consultation		
19	LEDGE	-	WITHOUT LEDGE - in the case of additional order (if the trench heater is embedded without the ledge, say so in the note, in such case the grille's width is different)
		L	L - peripheral ledge 15x15x1,5 mm to cover expansion gaps, the position of the code 20 determines the surface finish
		J	J - peripheral ledge that forms a peripheral rectangle with the width of 4 mm
20	COLOUR OF LEDGE	-	in the case when the ledge is not installed
		1	NATUR anodized aluminium ledge
		2	BRONZE anodized aluminium ledge
		3	BLACK anodized aluminium ledge
		9	other colour, i.e surface finish of sprayed powder colour according to the RAL sample list
21	CONNECTION RIGHT/LEFT	L	Connection of the heating medium ON THE LEFT side when installing the heat exchanger at the window, the fan towards the room's centre (standard)
		R	Connection of the heating medium ON THE RIGHT side when installing the heat exchanger at the window, the fan towards the room's centre
		A	OTHER, e.g. the left/right connection into the bottom, with combined trench heaters connection in the middle etc.
22	SELFSTANDING	-	STANDARD setting elements, they are not load-bearing, they just serve to set the right height
		B	SETTING BOLTS 0-35 mm, densely set screws in the trench heater's bottom, load-bearing
		P	FLAT BAR STEEL WITH SCREWS 5-70 mm, the bottom is supported with straps with screws M10, load-bearing
		K	BRACKETS 50-300 mm, special anchoring „on feet“
23	REGULATION	0	FRK, trench heater without fans (with natural convection)
		5	FRT, 24 V DC fans installed
24	ATYPICAL		Empty field, standard version of the trench heater
		A	Atypical version of the trench heater



Manufacturers & Suppliers
of Heating Products

RCM Heating
12-14 Sunbeam Road
Woburn Road Industrial Estate
Kempston
Bedfordshire
MK42 7BY

Phone: 01234 – 843303
Fax: 01908 – 483930
Mail: sales@rcmheating.co.uk
www.rcmheating.co.uk